

1 2 3 4 5 6 7 8

A  
B  
C  
D  
E  
F

A  
B  
C  
D  
E  
F

Ⓑ

PAAD253518	HT CW static pressure adjustment: with separate expansion tank
PAAD361057	HT CW static pressure adjustment: with separate buffer-unit

SEE TABLE

Net Weight		Quantity PER ENGINE	SEQ NO	Material ID	Material Name	Dimension, Occ	Standard or Drawing	Basic Material Material Standard	Weight GR./NET
0,001	0,001								
1	1	003	107.429.532.500	CONCEPT GUIDANCE Freshwater generation	107.429.532				0,001
1	-	002	PAAD360828	CENTRAL COOLING WATER SYSTEM HT_static-pressure: Buffer-unit	DAAD133030				0,001
-	1	001	PAAD253055	CENTRAL COOLING WATER SYSTEM HT_static-pressure: EXP tank	DAAD087048				0,001

Material ID	Free space for lic.	Modif.	Number	Drawn date	Number	Drawn date	Number	Drawn date	Number	Drawn date
PAAD361057	PAAD253518	Ⓐ	EAAD089971	25.11.2018	Ⓑ	EAAD092431	20.07.2020			



Product  
W5-8X52DF

COOLING WATER SYSTEMS  
INSTALLATION DRAWINGS  
Kuehlwassersystem

SURFACE PROTECTION SEE GROUP 0344	Made	14.02.2017	dk1021	DH.Kim	Scale	-	Size	A3	Page	1/1	Material ID	
TOLERANCING PRINCIPLE ISO8015	Chkd	28.07.2017	wwa008	Wang	Design Group	9721	Drawing ID	DAAD087205		Rev.	B	
GENERAL TOLERANCES ACCORDING TO ISO2768-mK	Appd	28.07.2017	mhu019	Hug								

Approved  
D  
E  
F  
DIMENSIONAL DRAWING - Confidential

SPECIFICATION which must be met:

⑧ OUTLET - Scavenge air cooler (SAC) cooling water (LT water)  
 - Cooling water volume flow: according to GTD specification, adjusted by an orifice in the outlet pipe on shipside.

② INLET - Cylinder cooling water (HT water)  
 - Cooling water pressure: 3.0 - 5.0 bar  
 - Cooling water volume flow: according to GTD specification  
 - Cooling water (freshwater) must be treated according to WinGD's specification.  
 - Pre-heating: The engine must be warmed-up by means of heated HT water to min. 60°C before engine start.  
 - HT cooling water amount on engine side: Given in table1 on page 2

③ OUTLET - Cylinder cooling water (HT water)  
 - Cooling water temperature  
 - Controller set-point: 90 °C (controller type: PI)  
 - Steady state condition: 90 ± 2 °C  
 - Transient condition: 90 ± 4 °C  
 - A venting devise (air separator) must be installed as close as possible after the outlet connection. Venting air must be released to a safe area outside of the engine room.

⑦ INLET - Scavenge air cooler (SAC) cooling water (LT water)  
 - Cooling water pressure: 2.0 - 4.0 bar  
 - Cooling water temperature set point: 25 °C, max. 36 °C when seawater temperature at 32 °C.  
 - Cooling water volume flow: according to GTD specification.  
 - Cooling water (freshwater) must be treated according to WinGD's specification.  
 - LT cooling water amount on engine side: Given in table1 on page 2.

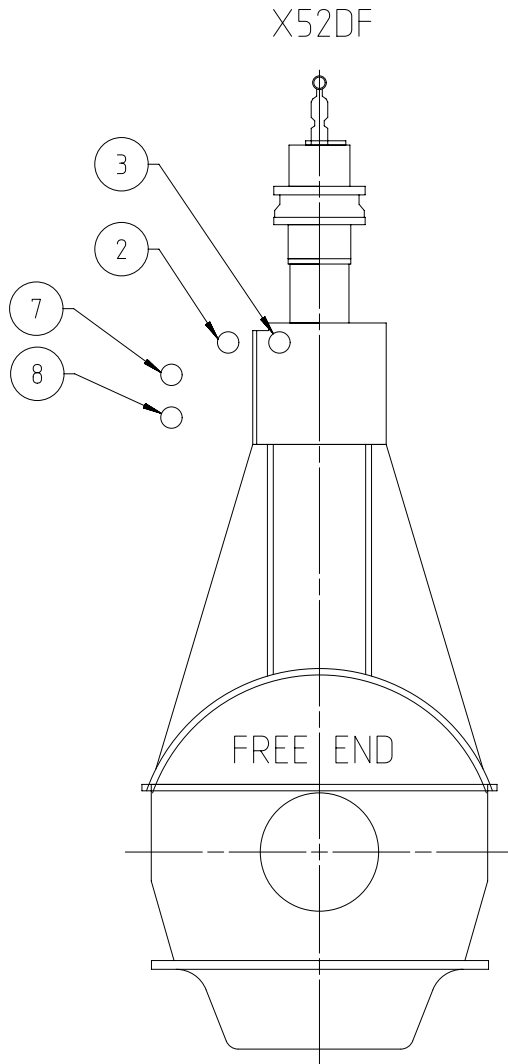

1	026	PAAD297120	AIR SEPARATOR	DAAD101945		0,001	
1	016	107.245.419.500	EXPANSION TANK	107.245.419		0,001	
1	015	PAAD166922	EXPANSION TANK	DAAD052664		0,001	
QTY	SEQ NO	Material ID	Material Name	Dimension, Occ	Standard or Drawing	Basic Material Material Standard	Weight GR./NET

Free space for lic.	Q-Code					Main Drw.
	XXXXXX					
Standard						Weight GR./NET
ISO; JIS						

Modif.	A	EAAD088733	22.12.2017	B	EAAD089971	25.11.2018	C	EAAD090373	09.09.2019	D	EAAD092431	25.02.2020
	Number	Drawn date		Number	Drawn date		Number	Drawn date		Number	Drawn date	

Product 5-8X52DF

CENTRAL COOLING WATER SYSTEM

HT\_static-pressure: EXP tank

Units	mm kg	NX	Basic Material	Net Weight 0,001
-------	-------	----	----------------	------------------

SURFACE PROTECTION SEE GROUP 0344	Made	02.08.2017	dk1021	DH.Kim	Scale	-	Size	A3	Page	1/2	Material ID	PAAD253055
TOLERANCING PRINCIPLE ISO8015	Chkd	28.07.2017	wwa008	Wang	Design Group	9721	Drawing ID	DAAD087048	Rev.	D		
GENERAL TOLERANCES ACCORDING TO ISO2768-mK	Appd	28.07.2017	mhu019	Hug								

Approved  
 DIM - DIMENSIONAL DRAWING - Confidential

# SYSTEM PROPOSAL

Pos.	ENGINE COMPONENTS *3)
EC01	Scavenge air cooler (SAC)
EC02	Manual vent valve, for each cylinder *15)

Table 1: Water content on engine side

Cylinder	HT circuit Cyl. C.W. Volume (l)	LT circuit SAC Volume (l)
5	450 l	370 l
6	540 l	400 l
7	620 l	480 l a) / 510 l b)
8	710 l	550 l

a) Values for executions with 1 scavenge air cooler.  
b) Values for executions with 2 scavenge air coolers.

Pos.	ENGINE CONNECTIONS *2) D
2	INLET - Cylinder cooling water (HT water)
3	OUTLET - Cylinder cooling water (HT water)
7	INLET - Scavenge air cooler (SAC) cooling water (LT water) *7)
8	OUTLET - Scavenge air cooler (SAC) cooling water (LT water) *7)

Number of cylinders		5	6	7	8
Main engine X52DF (R1 rated)	power (kW)	7450	8940	10430	11920
	speed (rpm)	105			
Pressure drop across the engine	(bar)	1.3			
Cooling water expansion tank (HT)	Cap. (m³)	Depending on ancillary plants min. 10% of HT cooling water			
Cooling water expansion tank (LT)	Cap. (m³)	Depending on ancillary plants min. 10% of LT cooling water			

PROPOSAL for pipe dimensioning \*11)

Nominal pipe diameter D	Yard determination, suitable for main engine and ancillary plants			
	A	B	C	D
DN 200	200	250	250	250
DN 100	100	125	125	125
DN 65	65	65	65	80
DN 80	80	100	100	100

Pos.	SYSTEM COMPONENTS *1)
001	Low sea chest
002	High sea chest
003	Seawater strainer
004	Air vent (air vent pipe or equal venting system acc. to shipyard's design)
005	Seawater circulating pump
006	Central cooler (LT cooling water) D
007	Automatic temperature control valve for LT circuit *13)
008	LT water temperature sensor *13)
009	Cooling water pump for LT circuit
010	Lubricating oil cooler
011	Automatic temperature control valve for HT circuit *14)
012	HT water temperature sensor *14)
013	Cylinder cooling water pump for HT circuit
014	Pre-heating circulating pump (optional), cap. 10% from cylinder cooling pump *8)
015	HT water expansion tank (link to detail drawing on page 1) *17)
016	LT water expansion tank (link to detail drawing on page 1) *17) D
017	Pre-heater for main engine (HT circuit)
018	Throttling disc *5)
019	Freshwater generator
020	Chemical treatment refill unit *4)
021	HT cooling water cooler
022	Transition piece (adapter) *9)
023	Cylinder cooling water air venting line *10)
024	MDO/MGO cooler
025	Filling pipe / inlet chemical treatment
D 026	Air separator (link to details drawing on page 1)
D 027	Automatic venting unit
D 028	Gas Detector *10)

- Remarks:
- Air vent and drain pipes not shown on drawing. Shall be installed where required.
  - Air vent and drain pipes must be fully functional at all inclination angles of the ship at which the engine must be operational.
  - \*1) To be delivered by external supplier and to be installed by the shipyard.
  - \*2) Refer to the "Pipe Connection Plan" for the execution and location of the engine pipe connection.
  - \*3) To be delivered by the engine manufacturer, i.e. already equipped on engine side.
  - \*4) To be installed for cooling water after-treatment during regular engine operation. Convenient dimensions are provided in view 'X'. Other designs are possible.
  - \*5) When using a valve, lock in proper position to avoid mishandling.
  - \*6) Only when pos. 014 is installed.
  - \*7) The inlet and outlet pipes to SAC must be designed to allow engine thermal expansion, or be fitted with expansion pieces.
  - \*8) For guidance only, final layout according to actual engine pre-heating requirements.
  - \*9) Installed as required (check with "Pipe Connection Plan")
  - \*10) To be vented to a safe area outside of engine room. In addition, depending on flag state and/or class requirement, the venting line may also be equipped with a glass detector in order to achieve IGC compliance.
  - \*11) All given diameters are valid for the mentioned rating and serve just as an example. To make the layout for the project specific rating please refer to DG9730 "Fluid velocities and flow rates, recommended values for pipework of diesel plants" for selecting the appropriate pipe diameter. Rating specific flow rates are provided by GTD.
  - \*12) A constant temperature at engine (SAC) inlet must be maintained. Recommended controller set-point for main engine operation is 25 °C. If the ancillary plants require a temperature lower or greater than the LT water set-point, a separate water supply system with different temperature set-point has to be installed (please refer to the system proposal in MIM)
  - \*13) A constant temperature at engine outlet must be maintained. Recommended controller set-point for main engine operation is 90 °C.
  - \*14) Only to be used for manual venting of isolated cylinders after maintenance. To be kept close during engine operation.
  - \*15) Optional, only to be installed if needed for hydraulic balancing.
  - \*16) If gas driven auxiliaries are connected to the HT expansion tank) and has to be vented to a safe area outside of engine room.
  - \*17) Optional connection, to be installed if requested by class rules for emergency engine cooling.

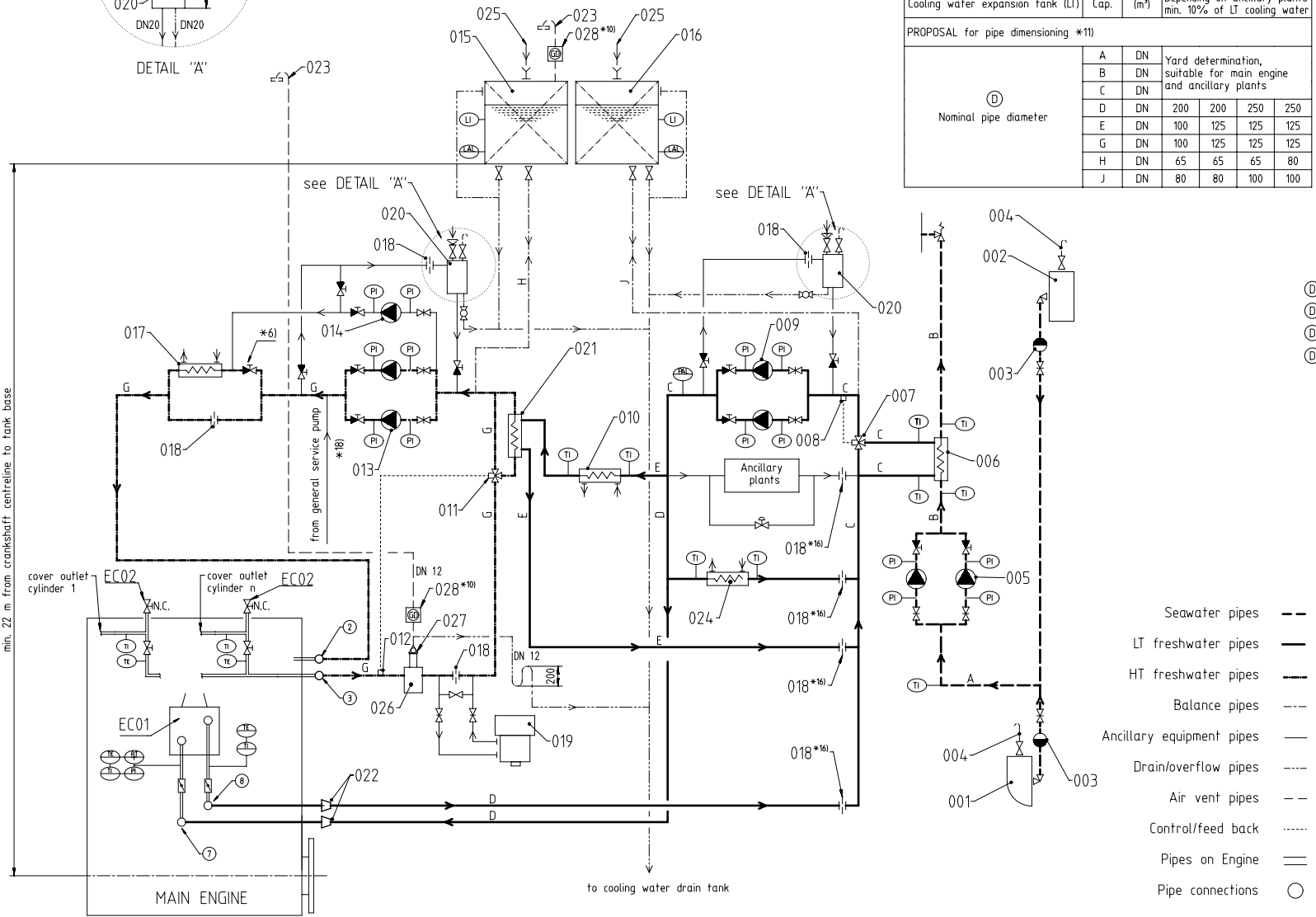
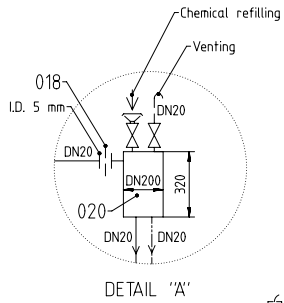

- Seawater pipes ---
- LT freshwater pipes —
- HT freshwater pipes - - -
- Balance pipes - - - - -
- Ancillary equipment pipes —
- Drain/overflow pipes - - - - -
- Air vent pipes - - -
- Control/feed back - - - - -
- Pipes on Engine —
- Pipe connections ○

Q-Code	XXXXXX	Main Drw.
Standard	ISO, JIS	
Product	5-BX52DF	
Project	CENTRAL COOLING WATER SYSTEM	
HT_static-pressure:	EXP tank	

Units	mm kg	NX	Basic Material		Net Weight	0,001	
Scale	-	Size	AT	Page	2/2	Material ID	PAAD253055
Design Group	9721	Drawing ID	DAAD087048	Rev.	D		

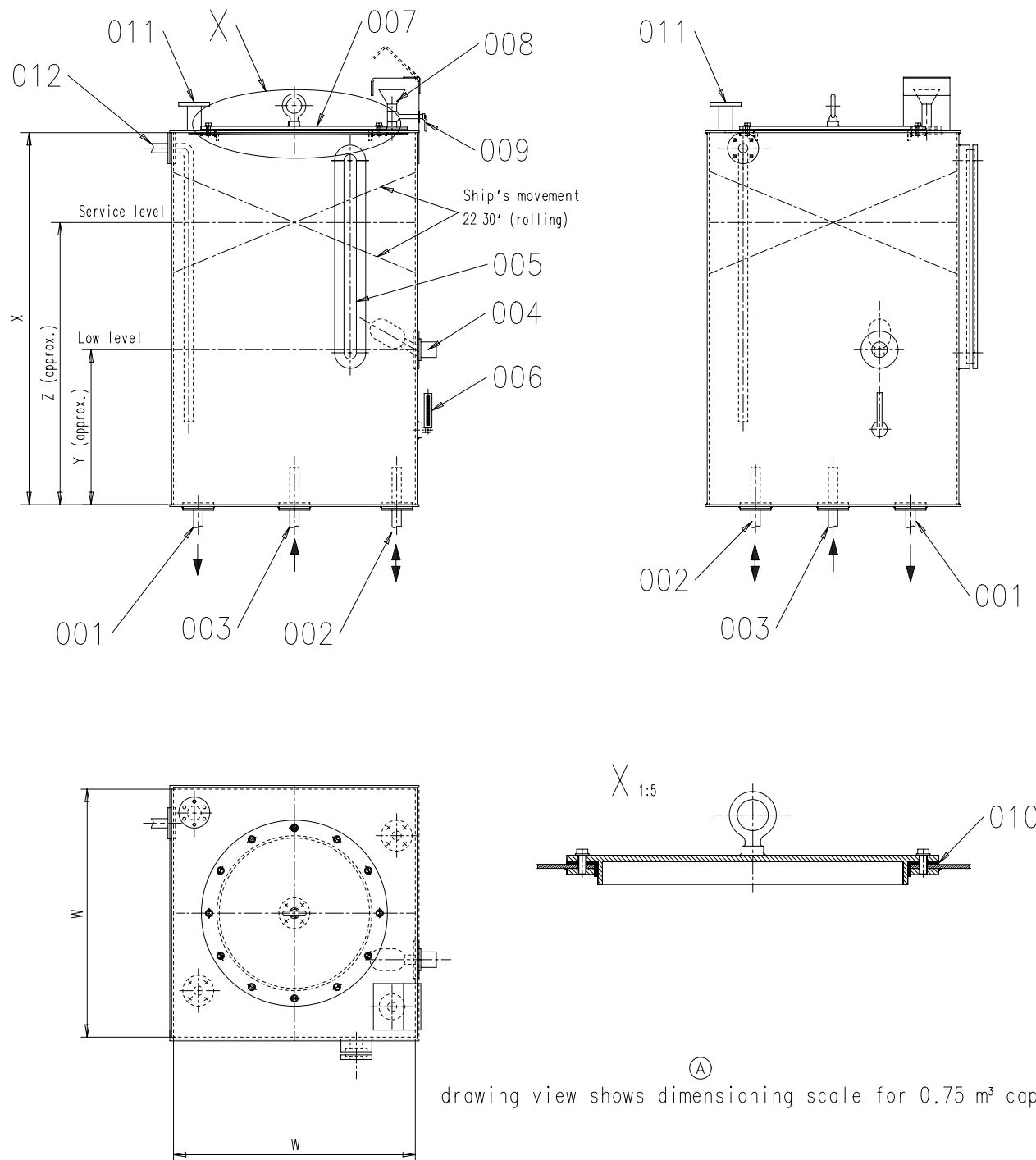

(A) drawing view shows dimensioning scale for 0.75 m³ capacity

Pos.	Description
001	Drain from HT circuit
002	Balance pipe from HT circuit
(A) 003	Air vent from HT circuit *5)
004	Low level alarm *4)
005	Level indicator *1) *4)
006	Thermometer *4)
007	Inspection cover (manhole) *2)
008	Filling pipe/inlet chemical treatment *2)
009	Cock *3)
010	Sealing
011	Venting *6)
012	Overflow/air vent

Remarks: (A)

- \*1) Level indicator can be omitted if an alternative is fitted.
- \*2) Other gas tight solutions are also possible.
- \*3) Has to be closed always after treatment.
- \*4) Any instrumentation installed in the system has to be certified explosion proof apparatus.
- \*5) This connection is only needed if the HT cooling water system venting is done via the expansion tank.
- \*6) To be vented outside of engine room

- Tank dimensions are defined by the Tank capacity, as seen in Table 1. For capacity and pipe diameter, refer to drawing 'Central cooling water system'.

Table 1: Tank dimensions

HT Tank capacity	W	X	Y	Z
(m³)	(mm)	(mm)	(mm)	(mm)
0.5	800	800	330	640
0.75	800	1200	500	960
1.0	800	1600	670	1280
1.25	1000	1250	530	1000
1.5	1000	1500	630	1200
1.75	1000	1750	730	1400
2.0	1000	2000	830	1600

Free space for file		Q-Code XXXXXX Standard ISO; JIS		Main Drw.
Modif. (A)	EAAD091567	15.11.2019		
Number	Drawn date	Number	Drawn date	Number
Product W-2S		EXPANSION TANK CENTRAL COOLING WATER HT CIRCUIT Ausgleichstank Zentralkuehlwassersystem HT circuit		
Units mm kg NX		Basic Material		Net Weight 0,001
SURFACE PROTECTION SEE GROUP 0344		Made 07.07.2014 mhu019 M.Hug	Scale 1:10	Size A2 Page 1/1
TOLERANCING PRINCIPLE ISO8015		Chkd 08.08.2014 bha009 Haag	Design Group	Material ID PAAD166922
GENERAL TOLERANCES ACCORDING TO ISO2768-mK		Appd 08.08.2014 bha009 Haag	9721	Drawing ID DAAD052664
				Rev. A

# X52DF DRIVING END

FUEL SIDE

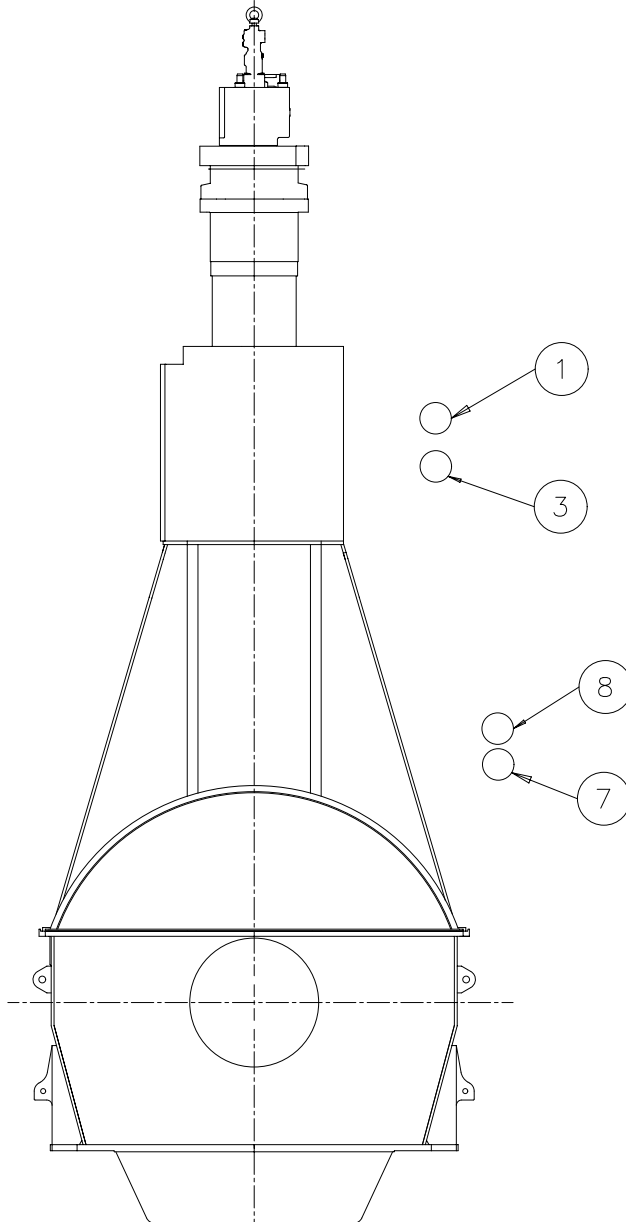

EXHAUST SIDE

## Specifications which must be met:

1	<p>INLET - Cylinder cooling water (HT water)</p> <ul style="list-style-type: none"> <li>- Cooling water pressure: 3.0 - 5.0 bar</li> <li>- Cooling water volume flow: according to GTD specification</li> <li>- Cooling water (freshwater) must be treated according to WinGD's specification.</li> <li>- Pre-heating: The engine must be warmed-up by means of heated HT water to min. 60°C before engine start.</li> <li>- HT cooling water amount on engine side: Given in table1 on page 2</li> </ul>
3	<p>OUTLET - Cylinder cooling water (HT water)</p> <ul style="list-style-type: none"> <li>- Cooling water temperature</li> <li>- Controller set-point: 90 °C (controller type: PI)</li> <li>- Steady state condition: 90 ± 2 °C</li> <li>- Transient condition: 90 ± 4 °C</li> <li>- A venting devise (air separator) must be installed as close as possible after the outlet connection. Venting air must be released to a safe area outside of the engine room.</li> </ul>
7	<p>INLET - Scavenge air cooler (SAC) cooling water (LT water)</p> <ul style="list-style-type: none"> <li>- Cooling water pressure: 2.0 - 4.0 bar</li> <li>- Cooling water temperature set point: 25 °C, max. 36 °C when seawater temperature at 32 °C.</li> <li>- Cooling water volume flow: according to GTD specification.</li> <li>- Cooling water (freshwater) must be treated according to WinGD's specification.</li> <li>- LT cooling water amount on engine side: Given in table1 on page 2.</li> </ul>
8	<p>OUTLET - Scavenge air cooler (SAC) cooling water (LT water)</p> <ul style="list-style-type: none"> <li>- Cooling water volume flow: according to GTD specification, adjusted by an orifice in the outlet pipe on shipside.</li> </ul>

1	029	PAAD297120	AIR SEPARATOR	DAAD101945		0,001	
1	021	107.245.4.19.500	EXPANSION TANK	107.245.4.19		0,001	
1	020	107.245.626.500	BUFFER	107.245.626		0,001	
QTY	SEQ NO	Material ID	Material Name	Dimension, Occ	Standard or Drawing	Basic Material Material Standard	Weight GR./NET

Free space for lic.	Q-Code	Main Draw.
	XXXXXX	
	Standard	
	ISO; JIS	

Modif.	Number	Drawn date	Number	Drawn date	Number	Drawn date	Number	Drawn date
		Product 5-8X52DF		CENTRAL COOLING WATER SYSTEM HT_static-pressure: Buffer-unit Zentralkuehlwassersystem				
Units	mm kg	NX	Basic Material	Net Weight 0,001				

SURFACE PROTECTION SEE GROUP 0344	Made	16.07.2020	Sudant Deogade	Scale	-	Size	A2	Page	1/2	Material ID	PAAD360828
TOLERANCING PRINCIPLE ISO8015	Chkd	30.09.2020	jpi101 Pickup	Design Group		Drawing ID	DAAD133030	Rev.	-		
GENERAL TOLERANCES ACCORDING TO ISO2768-mK	Appd	30.09.2020	mhu019 Hug	9721							

# SYSTEM PROPOSAL

Pos.	ENGINE CONNECTIONS *2)
①	INLET - Cylinder cooling water (HT water)
③	OUTLET - Cylinder cooling water (HT water)
⑦	INLET - Scavange air cooler (SAC) cooling water (LT water) *7)
⑧	OUTLET - Scavange air cooler (SAC) cooling water (LT water) *7)

Main engine X52DF (R1 rated)	Number of cylinders				
	5	6	7	8	
power (kW)	7450	8940	10430	11920	
speed (rpm)	105				
Buffer unit for HT circuit	Cap. (m³)	0.8	0.8	0.8	0.8
Cylinder cooling water feed tank only min.	Cap. (m³)	1.5	1.5	1.5	1.5
CCW feed and drain tank (combined) min.	Cap. (m³)	4	4	4	4
Cooling water expansion tank (LT)	Cap. (m³)	Depending on ancillary plants			

Pos.	ENGINE COMPONENTS *3)
EC01	Scavange air cooler
EC02	Manual vent valve, for each cylinder *16)

PROPOSAL for pipe dimensioning \*11)

Nominal pipe diameter	Yard determination, suitable for main engine and ancillary plants			
	A	B	C	D
D DN	200	200	250	250
E DN	100	125	125	25
F DN	100	125	125	125
I DN	65	65	65	80
J DN	80	80	100	100
K DN	20	20	20	20

Pos.	SYSTEM COMPONENTS *1)
001	Low sea chest
002	High sea chest
003	Seawater strainer
004	Air vent (air vent pipe or equal venting system acc. to shipyard's design)
005	Seawater circulating pump
006	Central cooler (LT cooling water)
007	Automatic temperature control valve for LT circuit *13)
008	Temperature sensor of regulating system *13)
009	Cooling water pump for LT circuit
010	Lubricating oil cooler
011	Automatic temperature control valve for HT circuit *14)
012	Temperature sensor of regulating system *14)
013	Cylinder cooling water pump for HT circuit
014	Pre-heating circulating pump (optional), cap. 10% from cylinder cooling pump *8)
015	Pre-heater for main engine (HT circuit)
016	Solenoid valve (air inlet to be interlocked with min. water level)
017	Control air valve with air release function *15) (to be adjusted to ensure CW pressure at ME inlet 4 - 5 bar(g))
018	Throttling disc *5)
019	Freshwater generator
020	Buffer unit for HT circuit (link to detail drawing on page 1) *17)
021	LT water expansion tank (link to detail drawing on page 1) *20)
022	Filling pipe / inlet chemical treatment
023	Cylinder cooling water feed & drain tank (or feed tank only)
024	Cylinder cooling water cooler
025	Supply pump, automatic level control (0.5 m³/h at 4 bar)
026	Chemical treatment refill unit *4)
027	Transition piece (adapter) *9)
028	MDO/MGO cooler
029	Air separator (link to details drawing on page 1)
030	Automatic venting unit
031	Gas detector *10)

**Remarks:**

- Air vent and drain pipes not shown on drawing. Shall be installed where required.
- Air vent and drain pipes must be fully functional at all inclination angles of the ship at which the engine must be operational.
- \*1) To be delivered by external supplier and to be installed by the shipyard.
- \*2) Refer to the "Pipe Connection Plan" for the execution and location of the engine pipe connection.
- \*3) To be delivered by the engine manufacturer, i.e. already equipped on engine side.
- \*4) To be installed for cooling water after-treatment during regular engine operation. Convenient dimensions are provided in view "A". Other designs are possible.
- \*5) When using a valve, lock in proper position to avoid mistandling.
- \*6) Only when pos. 014, is installed.
- \*7) The inlet and outlet pipes to SAC must be designed to allow engine thermal expansion, or be fitted with expansion pieces.
- \*8) For guidance only, final layout according to actual engine pre-heating requirements.
- \*9) Installed as required (check with "Pipe Connection Plan")
- \*10) To be vented to a safe area outside of engine room. In addition, depending on flag state and/or class requirement, the venting line may also be equipped with a gas detector in order to achieve IGC compliance.
- \*11) All given diameters are valid for the mentioned rating and serve just as an example. To make the layout for the project specific rating please refer to DG9730 "Fluid velocities and flow rates, recommended values for pipework of diesel plants" for selecting the appropriate pipe diameter. Rating specific flow rates are provided by GTO.
- \*13) A constant temperature at engine (SAC) inlet must be maintained. Required controller set-point for main engine operations is 25 °C. If the ancillary plants require a temperature lower or greater than the LT water set-point, a separate water supply system with different temperature set-point has to be installed (please refer to the system proposal in M/M).
- \*14) A constant temperature at engine outlet must be maintained. Required controller set-point for main engine operation is 90 °C.
- \*15) If the selected control air valve does not have the integrated air release functionality a separate air release valve can be installed as alternative on the top of the buffer unit, close during engine operation.
- \*16) Only to be used for manual venting of isolated cylinders after maintenance. To be kept \*17) If instead of the buffer unit an expansion tank of enclosed type is installed it must be located at min. 23 m above the crankshaft centerline.
- \*18) Optional, only to be installed if needed for hydraulic balancing.
- \*19) Optional filling line to enable fast system re-filling (e.g. after complete system drainage) by means of the pre-heating pumps.
- \*20) If gas driven auxiliaries are connected to the LT circuit, the LT expansion tank must be gas tight and has to be vented to a safe area outside of engine room.

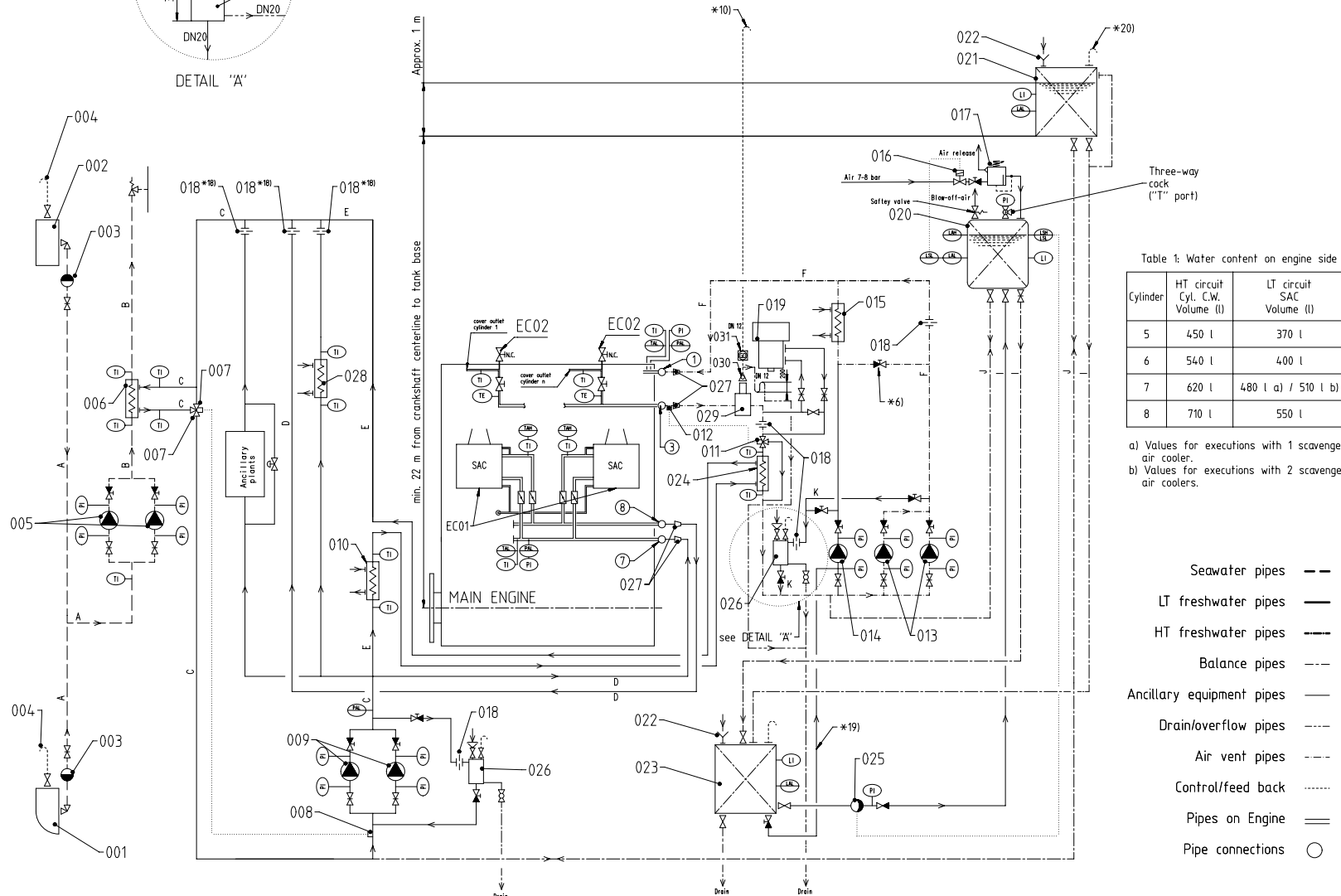
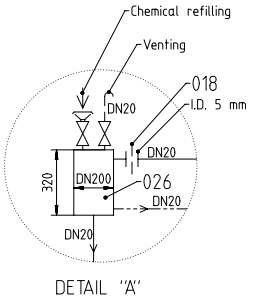

Table 1: Water content on engine side

Cylinder	HT circuit Cyl. C.W. Volume (l)	LT circuit SAC Volume (l)
5	450 l	370 l
6	540 l	400 l
7	620 l	480 l a) / 510 l b)
8	710 l	550 l

- a) Values for executions with 1 scavange air cooler.
- b) Values for executions with 2 scavange air coolers.

- Seawater pipes ---
- LT freshwater pipes —
- HT freshwater pipes - - -
- Balance pipes - - - -
- Ancillary equipment pipes —
- Drain/overflow pipes - - - -
- Air vent pipes - - - -
- Control/feed back - - - -
- Pipes on Engine —
- Pipe connections ○

SURFACE PROTECTION SEE GROUP 0344		Made 16.07.2020 Sudant Deogade		Scale -		Size A1		Page 2/2		Material PAAD360828		Net Weight 0,001	
TOLERANCING PRINCIPLE ISO8015		Chd 30.09.2020 jgr101 Pickup		Design Group		Drawing ID		DAAD133030		Rev. -			
GENERAL TOLERANCES ACCORDING TO ISO2768-mK		Appd 30.09.2020 mhu019 Hug		9721									

WINGD  
Wärthner Gas & Diesel

Product: 5-BX52DF  
CENTRAL COOLING WATER SYSTEM  
HT-static-pressure: Buffer-unit  
Zentralkühlwassersystem

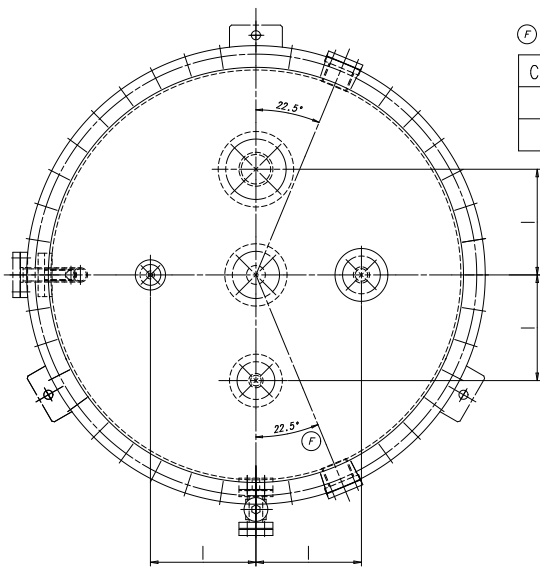
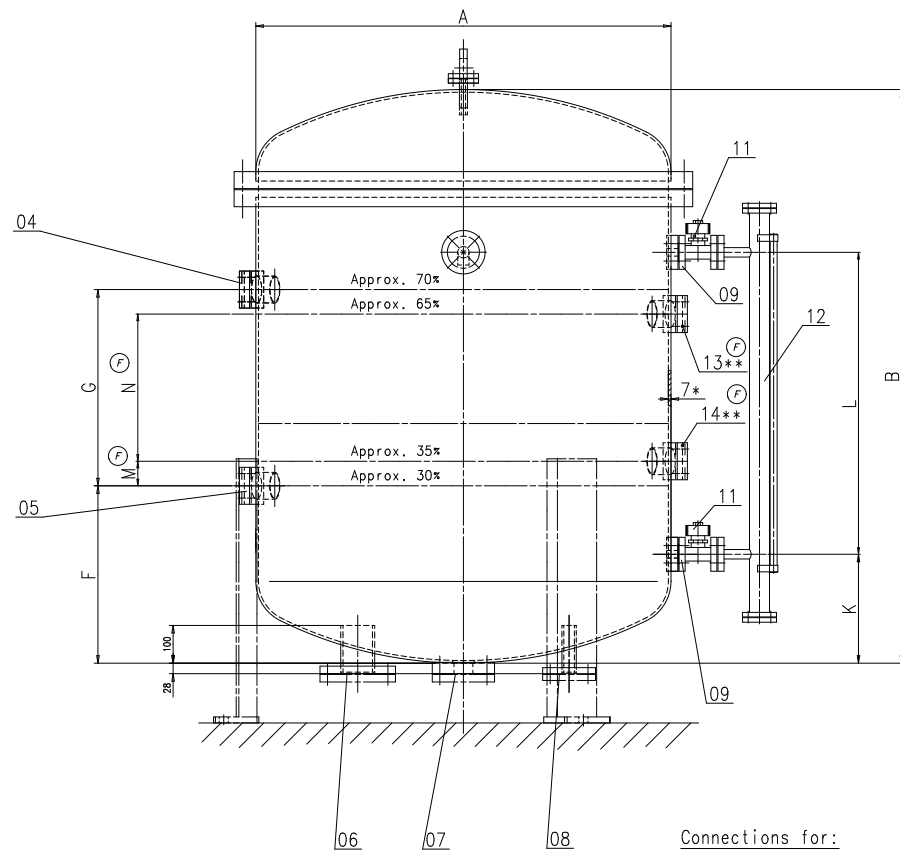
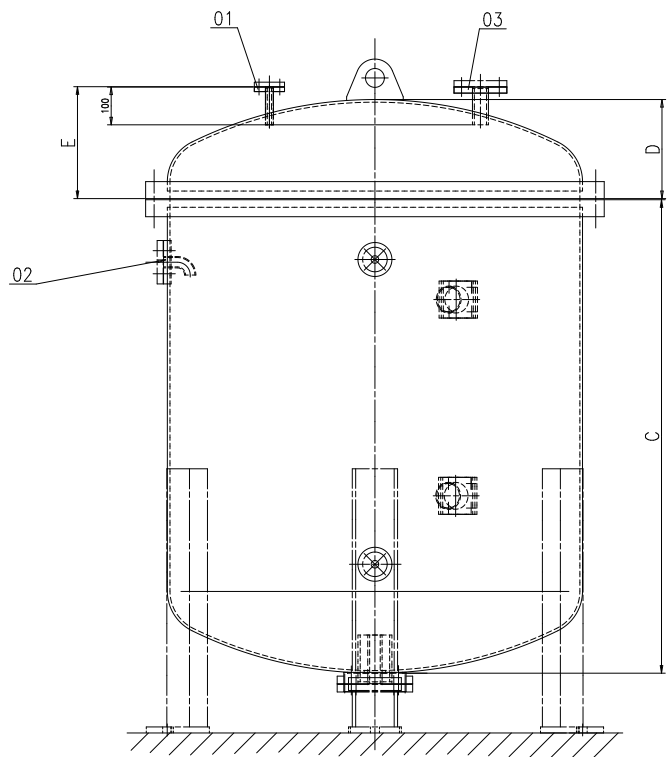

Capacity	A	B	C	D	E	F	G	H	I	K	L	M	N
800l	ø900	1430	1205	222	250	455	520	600	250	250	800	65	390
1200l	ø1100	1520	1255	262	300	470	520	650	280	290	800	65	390

Connections for:

- 01 Compressed air supply from control air valve, DN15 with blank flange
- 02 Pressure indicator, DN25 with blank flange
- 03 Safety and relief valve adjustment 5,5 bar DN32 with blank flange
- 04 Level alarm high, with blank flange
- 05 Level alarm low, with blank flange
- 06 Compensation, DN80 with blank flange
- 07 Drain, DN32 with blank flange
- 08 Feed, DN32 with blank flange
- 09 Flanges for level indicator
- (F) 11 Valve for level indicator, self-closing type
- 12 Level indicator
- 13 Level switch high, with blank flange \*\*
- 14 Level switch low, with blank flange \*\*

Working pressure : 5 bar

\* Wall thickness and test pressure : according to relevant classification society/rules

Service temperature : max. 95°C

(F) \*\* Tank volume between LSH and LSL shall be no less than 150 litres.

Drawn for 1200l capacity

1-41.644.105.03.2000 (L) (A) (B) (C) (D) (E) (F) (G) (H) (I) (J) (K) (L) (M) (N) (O) (P) (Q) (R) (S) (T) (U) (V) (W) (X) (Y) (Z)		14.08.2012 (E) (F) (G) (H) (I) (J) (K) (L) (M) (N) (O) (P) (Q) (R) (S) (T) (U) (V) (W) (X) (Y) (Z)	107.245.626.500
107.245.626.500	107.245.626.500	107.245.626.500	107.245.626.500
SURFACE PROTECTION SEE GROUP 0344		Scale: 1:5	No. Weight: 0.001
TOLERANCING PER EN ISO 2768		Date: 22.08.20	Dev. Group: S.57X/ANBY
GENERAL TOLERANCES ACCORDING TO ISO 2768-MS		No. 3721	No. 107.245.626
WIN GO		BUFFER TO CYL. COOLING WATER SYS Puffer	

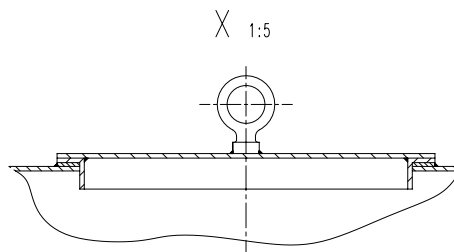
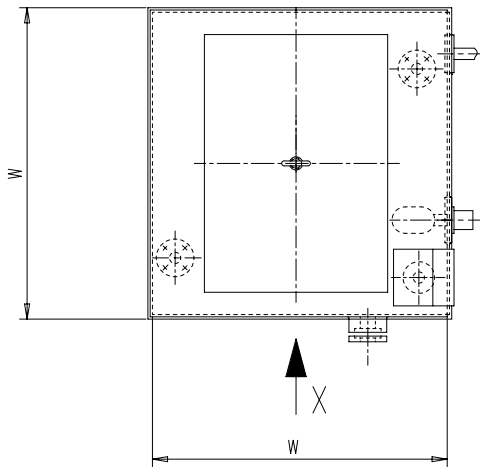
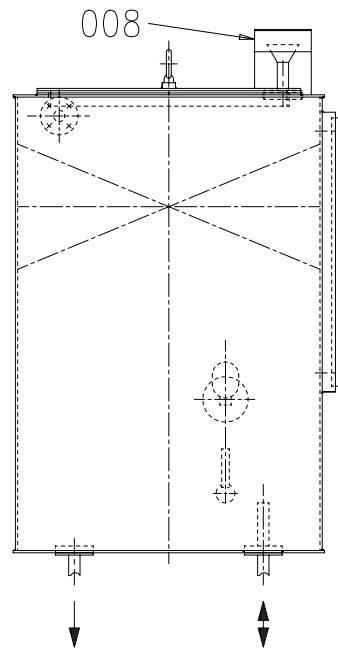
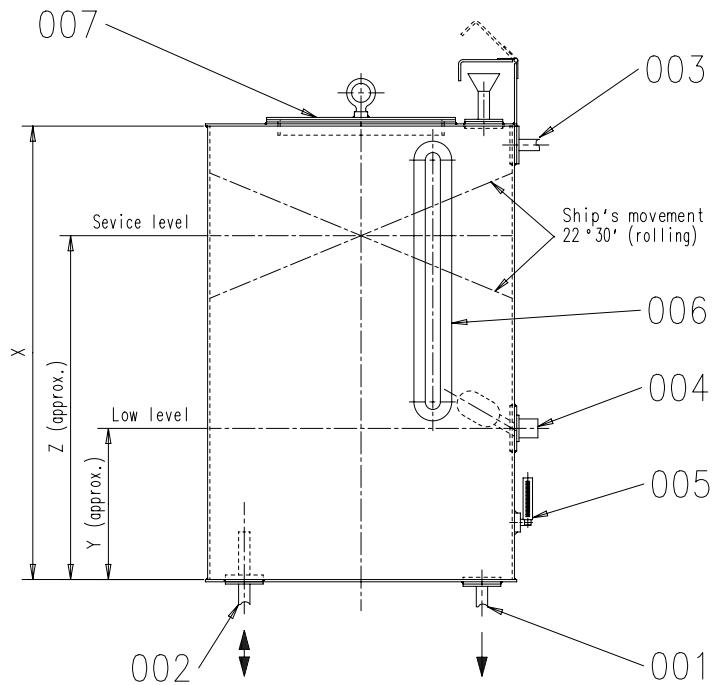

Drawn for 0.75 m<sup>3</sup> capacity

Pos.	Description (D)
001	Drain
002	Balance pipe from LT circuit
003	Overflow/air vent
004	Low level alarm
005	Thermometer
006	Level indicator *1)
007	Inspection cover *2)
008	Filling pipe/inlet chemical treatment *2)

Remarks:

- \*1) Level indicator can be omitted if an alternative is fitted.
- \*2) Other designs like hinged covers, etc. are also possible

- For required tank capacity and pipe diameters refer to drawing 'Central cooling water system'

Table 1: Tank dimensions

LT tank capacity ( m <sup>3</sup> )	W ( mm )	X ( mm )	Y ( mm )	Z ( mm )
0.5	800	800	330	640
0.75	800	1200	500	960
1.0	800	1600	670	1280
1.25	1000	1250	530	1000
1.5	1000	1500	630	1200
1.75	1000	1750	730	1400
2.0	1000	2000	830	1600

Free space for file	Q-Code				Main Drw.
	XXXXXX Standard ISO; JIS				
Modif.	A	B	C	D	
Number	EAAD014356	7-37.090	EAAD083145	EAAD091029	
Drawn date	16.06.1997	16.08.2007	25.01.2012	12.09.2019	
Product	W-2S				



EXPANSION TANK  
CENTRAL COOLING WATER LT CIRCUIT  
Ausgleichstank  
Zentralkuehlwassersystem LT

Units	mm kg	NX	Basic Material	Net Weight 0,001
Made	11.06.1997	T.LANDERT	Scale 1:10	Size A2 Page 1/1 Material 107.245.419.500
Chkd			Design Group	Rev. D
Appd	11.06.1997	WCH001 Service User	9721	107.245.419



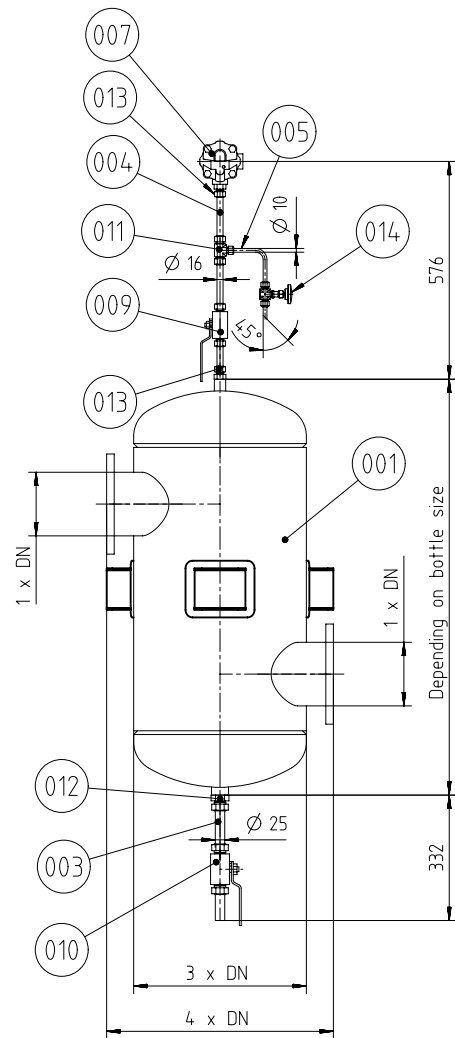

PIPE LENGTHS TO BE DECIDED BY SHIPYARD

1	014	107.324.704.001	NEEDLE VALVE DN7	107.324.704	Steel	0,438
2	013	107.324.101.017	SCREW-IN UNION DN12xG1/2	107.324.101	Steel	0,125
1	012	107.324.101.021	SCREW-IN UNION DN20xG1	107.324.101	Steel	0,329
1	011	107.324.131.007	TEE UNION DN12 x DN7	107.324.131	Steel	0,25
1	010	107.324.703.005	BALL VALVE DN20	107.324.703	Steel	1,24
1	009	107.324.703.003	BALL VALVE DN12	107.324.703	Steel	
1	007	PAAD185947	AUTOMATIC VENTING UNIT Rp1/2	DAAD065150		2,5
1m	005	005.405.131.043	PIPE DN7 / 10 x 1.5		W-FU-235-N-T	0,31
1m	004	005.405.131.087	PIPE DN12 / 16 x 2		W-FU-235-N-T	0,69
0,25m	003	005.405.131.131	PIPE DN20 / 25 x 2		W-FU-235-N-T	1,13
1	001	PAAD297112	AIR SEPARATOR	DAAD101890		139
QTY	SEQ NO	Material ID	Material Name Dimension, Occ	Standard or Drawing	Basic Material Material Standard	Weight GR./NET

Modif.	Free space for file		Q-Code XXXXXX Standard ISO; JIS		Main Drw.
A	EAAD090871	26.09.2019	B	EAAD096344	10.03.2021
Number	Drawn date	Number	Drawn date	Number	Drawn date

<b>WIN GD</b> Winterthur Gas & Diesel		Product W-25	AIR SEPARATOR		
Units	mm kg	NX	Basic Material	Net Weight 0.001	
Made	06.06.2018	Kashyap Patel	Scale	1:10	Size A2 Page 1/1
Chkd	17.07.2018	wwa008 Wang	Design Group	Material ID PAAD297120	
Appd	17.07.2018	mhu019 Hug	9721	Drawing ID	DAAD101945
SURFACE PROTECTION SEE GROUP 0344			TOLERANCING PRINCIPLE ISO8015		

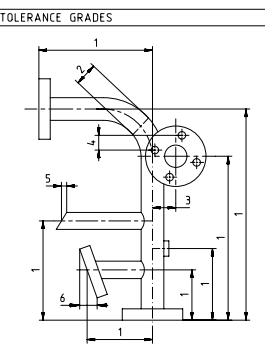

TOL. GRADE	DIMENSION NO.					
A	±1.0	*	±2.0	±2.0	±0.5	±0.5
B	±3.0	*	±3.0	±2.0	±0.5	±0.5
C	±6.0	*	±3.0	±2.0	±0.5	±0.5
A	±2.0	*	±2.0	±2.0	±1.0	±1.0
B	±4.0	*	±3.0	±3.0	±1.0	±1.0
C	±6.0	*	±3.0	±3.0	±1.0	±1.0

Rohrklasse PIPE CLASS	III	Medium MEDIUM	Wasser WATER	Pruefueberdruck TEST OVERPRESSURE	7,5	bar
Schweiss Qualitaet WELDING QUALITY LEVEL	D	Toleranzklasse TOLERANCE GRADE	B	Befr.druck OPER. PRESS.	5	bar

# AIR SEPARATOR PROPOSAL

SECTION H-H  
SCALE 1:2

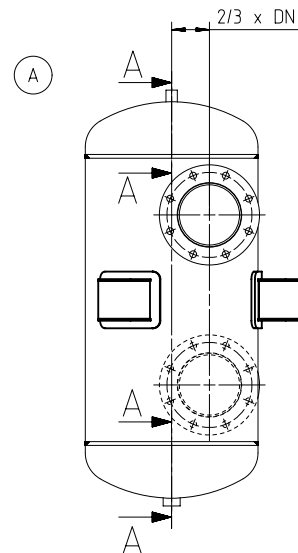
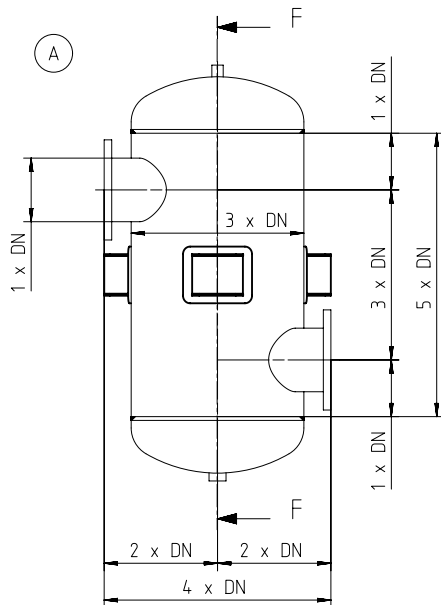
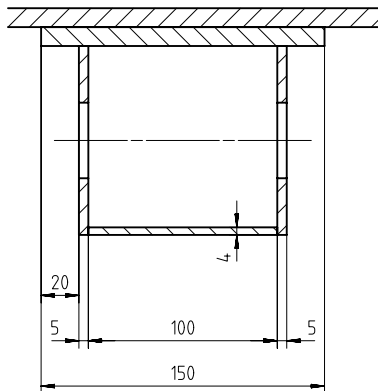

SECTION A-A  
SCALE 1:5

JIS

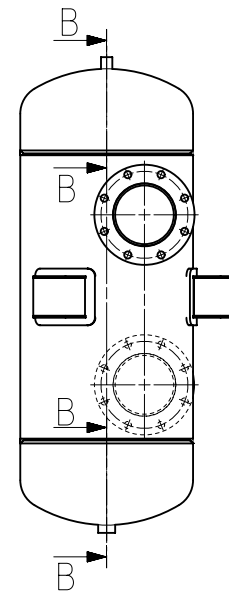

SECTION B-B  
SCALE 1:5

DETAIL G  
SCALE 1:2

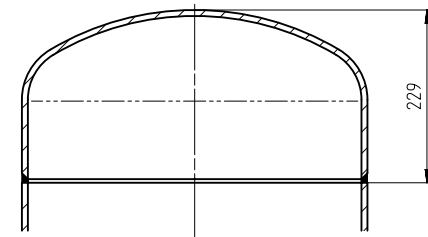
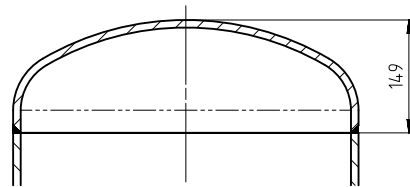
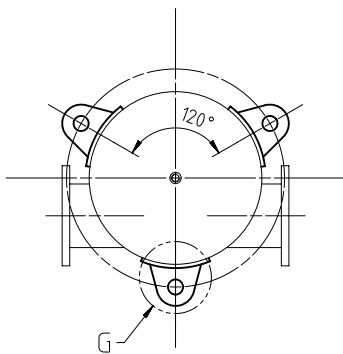
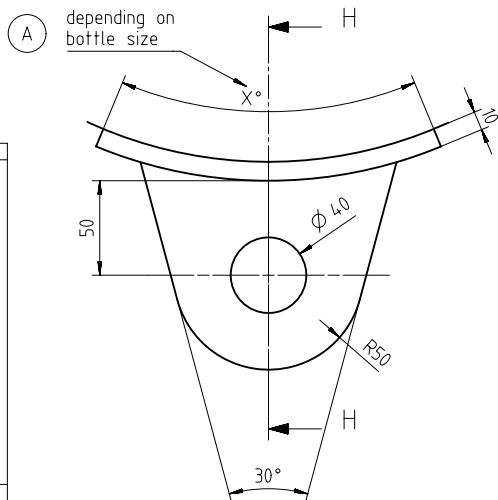

Qualitätsstufe D (siehe 4-107.345.444)  
WELD QUALITY LEVEL D (SEE 4-107.345.444)

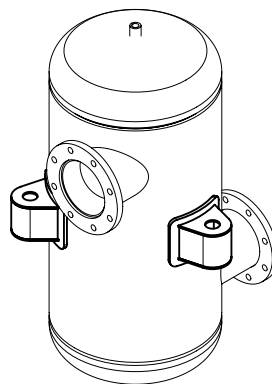

TOLERANCE GRADES

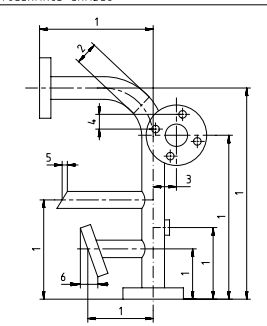

TOL. GRADE	1	2	3	4	5	6
A	±1.0	*	±2.0	±2.0	±0.5	±0.5
B	±3.0	*	±3.0	±2.0	±0.5	±0.5
C	±6.0	*	±3.0	±2.0	±0.5	±0.5
A	±2.0	*	±2.0	±2.0	±1.0	±1.0
B	±4.0	*	±3.0	±3.0	±1.0	±1.0
C	±6.0	*	±3.0	±3.0	±1.0	±1.0

Rohrklasse PIPE CLASS	III	Medium MEDIUM	Wasser WATER	Pruefueberdruck TEST OVERPRESSURE	7.5	bar
Schweiss Qualitaet WELDING QUALITY LEVEL	D	Toleranzklasse TOLERANCE GRADE	B	Betr.druck OPER. PRESS.	5	bar

Free space for file		Q-Code XXXXX		Main Drw.	
Standard ISO; JIS					
Modif.	A	EAAD090871	09.09.2019		
Number		Drawn date		Number	Drawn date
Product W-25			AIR SEPARATOR		
Units: mm kg NX			Basic Material		
Made: 05.06.2018 Kashyap patel			Scale: 1:10		
Chkd: 17.07.2018 wwa008 Wang			Size: A2 Page: 1/1		
Appd: 17.07.2018 mhu019 Hug			Material ID: PAAD297112		
SURFACE PROTECTION SEE GROUP 0344			Design Group		
TOLERANCING PRINCIPLE ISO8015			Drawing ID: DAAD101890		
			Rev: A		

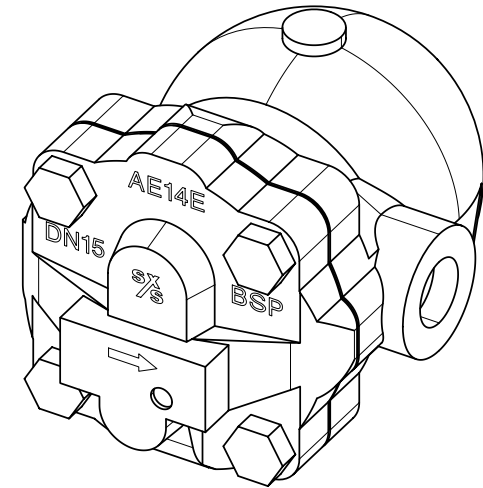
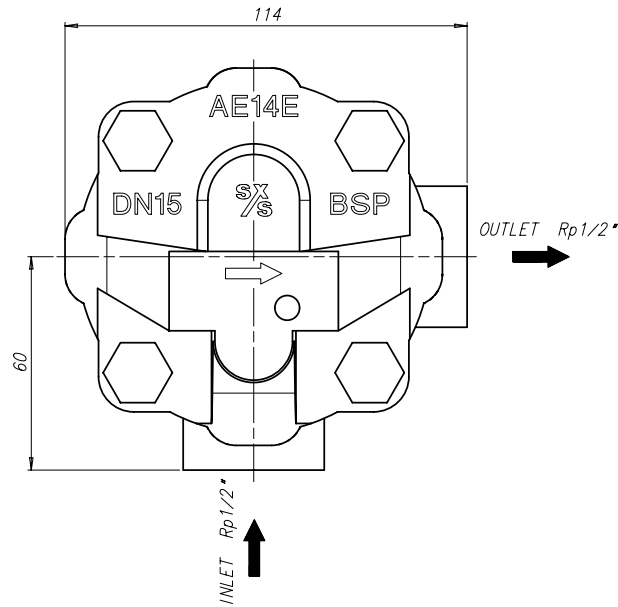
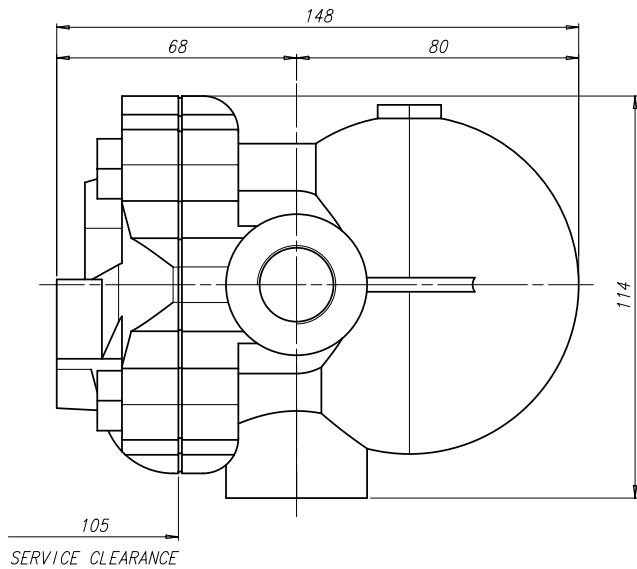

SUPPLIER:  
 SPIRAX SARCO AG  
 www.SpiraxSarco.com

SPECIFICATIONS:  
 AUTOMATIC AIR VENT SPIRAX SARCO TYPE AE14E, PN16, SIZE Rp1/2"  
 PRESSURE LEVEL : PN16  
 MAX. OPERATING PRESSURE (PMO): 14 bar  
 MAX. OPERATING TEMPERATURE (TMO): 127° C  
 MAX. PRESSURE DIFFERENCE : 14 bar

Face space for title	Q-Code						XQXXX	Main	
	Standard						ISO	Drw.	
						JIS			
Modif.	Number	Drawn date	Number	Drawn date	Number	Drawn date	Number	Drawn date	
		Product		AUTOMATIC VENTING UNIT ORDER DRAWING Entlüftungsautomat Bestellzeichnung					
Units		mm	kg	IDE	Basic Material		Net Weight 2.5		
SURFACE PROTECTION SEE GROUP 0344		Made	08.04.2015	Aditya Gole		Scale	1:1	Size	A2
TOLERANCING PRINCIPLE ISO8015		Chkd	27.05.2015	ast044 Stephan		Design Group	Material ID PAAD185947		
GENERAL TOLERANCES ACCORDING TO ISO2768-mK		Appd	27.05.2015	bha009 Haag		8611	Drawing ID	DAAD065150	

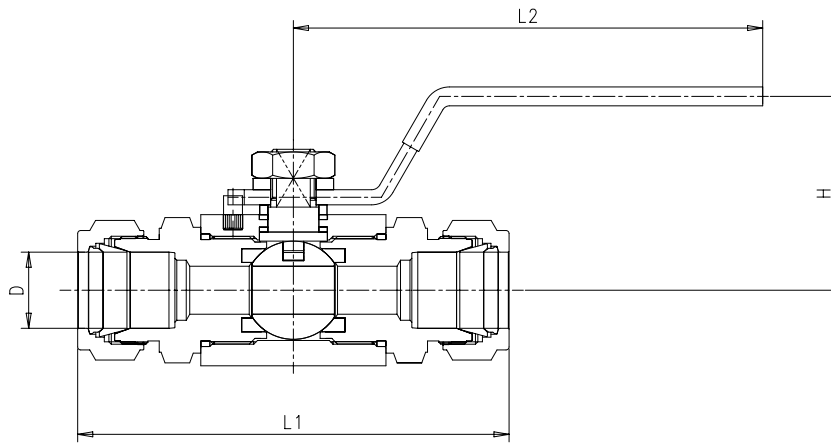

Artikel Nummer	DN	TUBE D	L1	L2	H	MAX. WORKING PRESSURE	OPERATING TEMPERATURE (°C)	Seat Material
107.324.703.001	DN07	10	104.91	108.75	38.41	6000 (413bar)	-30 to +180	PCTFE
107.324.703.002	DN09	12	109.71	108.75	38.41			
107.324.703.003	DN12	16	114.96	124.2	51.3			
107.324.703.004	DN15	20	114.16	124.2	53.1			
107.324.703.005	DN20	25	134.08	149.2	58.1			

siehe Hauptzeichnung für Spezifikation  
SEE MAIN DRAWING FOR SPECIFICATION

QTY	SEQ NO	Material ID	Material Name	Dimension, Occ	Standard or Drawing	Basic Material Material Standard	Weight GR./NET
1	005	107.324.703.005	BALL VALVE	DN20	107.324.703	Steel	1,24
1	004	107.324.703.004	BALL VALVE	DN15	107.324.703	Steel	1,03
1	003	107.324.703.003	BALL VALVE	DN12	107.324.703	Steel	0,55
1	002	107.324.703.002	BALL VALVE	DN9	107.324.703	Steel	0,511
1	001	107.324.703.001	BALL VALVE	DN7	107.324.703	Steel	0,494

Free space for file	Q-Code XXXXXX Standard ISO; JIS						Main Drw.	
	Modif.	EAAD700077	13.04.2011	EAAD083575	01.10.2012	EAAD096344		12.03.2021
	Number	Drawn date	Number	Drawn date	Number	Drawn date	Number	Drawn date
			Product W-2S		BALL VALVE Kugelhahn			
Units	mm kg	NX	Basic Material		Net Weight			

SURFACE PROTECTION SEE GROUP 034.4	Made	29.04.2005	sga006	S.GASSER	Scale	1:1	Size	A2	Page	1/1	Material ID	
TOLERANCING PRINCIPLE ISO8015	Chkd	S.Gasser		Design Group	0333			Drawing ID	107.324.703		Rev.	C
GENERAL TOLERANCES ACCORDING TO ISO2768-mK	Appd	04.05.2005	MFR001	Frei								

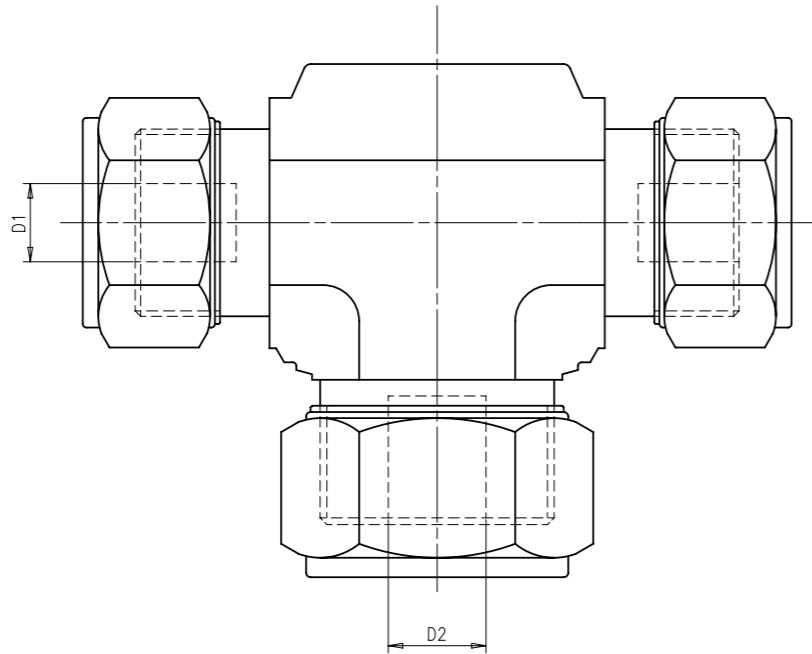

Artikel Nummer	DN	TUBE D1	TUBE D2
107.324.131.001	DN07	10	6
107.324.131.002	DN09	12	8
107.324.131.003	DN09	12	10
107.324.131.004	DN09	12	16
107.324.131.005	DN12	16	6
107.324.131.006	DN12	16	8
107.324.131.007	DN12	16	10
107.324.131.008	DN12	16	12
107.324.131.009	DN12	16	20
107.324.131.010	DN15	20	10
107.324.131.011	DN15	20	12
107.324.131.012	DN15	20	16
107.324.131.013	DN15	20	25
107.324.131.014	DN20	25	16
107.324.131.015	DN20	25	20

Ⓑ siehe Hauptzeichnung für Spezifikation  
SEE MAIN DRAWING FOR SPECIFICATION

QTY	SEQ NO	Material ID	Material Name	Dimension/Occ.Dimension	Standard or Drawing	Basic Material Material Standard	Weight OR A/E
1	015	107.324.131.015	TEE UNION	25 x 20 x 25	107.324.131	Steel	0.642
1	014	107.324.131.014	TEE UNION	25 x 16 x 25	107.324.131	Steel	0.615
1	013	107.324.131.013	TEE UNION	20 x 25 x 20	107.324.131	Steel	0.592
1	012	107.324.131.012	TEE UNION	20 x 16 x 20	107.324.131	Steel	0.471
1	011	107.324.131.011	TEE UNION	20 x 12 x 20	107.324.131	Steel	0.443
1	010	107.324.131.010	TEE UNION	20 x 10 x 20	107.324.131	Steel	0.46
1	009	107.324.131.009	TEE UNION	16 x 20 x 16	107.324.131	Steel	0.442
1	008	107.324.131.008	TEE UNION	16 x 12 x 16	107.324.131	Steel	0.262
1	007	107.324.131.007	TEE UNION	16 x 10 x 16	107.324.131	Steel	0.25
1	006	107.324.131.006	TEE UNION	16 x 8 x 16	107.324.131	Steel	0.243
1	005	107.324.131.005	TEE UNION	16 x 6 x 16	107.324.131	Steel	0.241
1	004	107.324.131.004	TEE UNION	12 x 16 x 12	107.324.131	Steel	0.271
1	003	107.324.131.003	TEE UNION	12 x 10 x 12	107.324.131	Steel	0.195
1	002	107.324.131.002	TEE UNION	12 x 8 x 12	107.324.131	Steel	0.19
1	001	107.324.131.001	TEE UNION	10 x 6 x 10	107.324.131	Steel	0.127

Q-Code	Material Standard	Weight OR A/E
XXXXXX		
ISO		
JIS		

Material	Number	Drawn date	Number	Drawn date	Number	Drawn date
A	EAAD700021	13.01.2011	B	EAAD083575	24.02.2012	

<b>WIN GD</b> Winterthur Gas & Diesel	Product W-2S	TEE UNION T-Verschraubung
--	-----------------	------------------------------

Units	mm	kg	IDE	Basic Material	Net Weight

Surface Protection	Scale	Size	Page	Material ID
SURFACE PROTECTION SEE GROUP 0344	1:1	A1	1/1	107.324.131

Chkd	Design Group	Drawing ID	Rev.
		0333	B

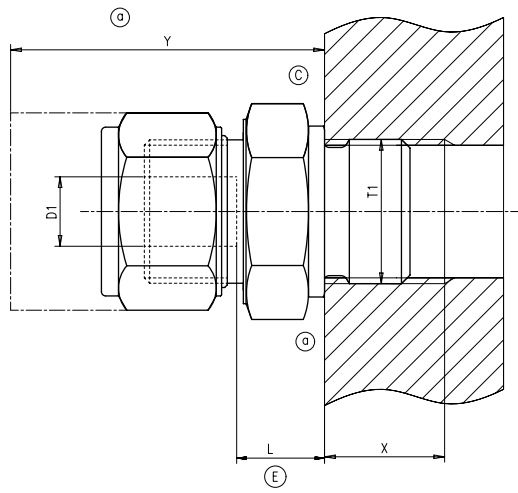

	ⓐ		ⓑ					ⓒ	
	Material ID	DN	TUBE D1	T1	X	Y	L	Order Number	
ⓐ	107.324.101.001	DN04	6	G1/8	9	45	9.9	DMC 6M-2GB-C	
	107.324.101.002	DN04	6	G1/4	14	50	11.1	DMC 6M-4GB-C	
	107.324.101.003	DN04	6	G3/8	14	50	12.4	DMC 6M-6GB-C	
	107.324.101.004	DN04	6	G1/2	17	55	15.2	DMC 6M-8GB-C	
	107.324.101.005	DN06	8	G1/8	9	45	9.9	DMC 8M-2GB-C	
ⓑ	107.324.101.006	DN06	8	G1/4	14	50	11.1	DMC 8M-4GB-C	
	107.324.101.007	DN06	8	G3/8	14	50	12.4	DMC 8M-6GB-C	
	107.324.101.008	DN06	8	G1/2	17	55	15.2	DMC 8M-8GB-C	
	107.324.101.009	DN07	10	G1/4	14	50	11	DMC 10M-4GB-C	
ⓒ	107.324.101.010	DN07	10	G3/8	14	50	12.2	DMC 10M-6GB-C	
	107.324.101.011	DN07	10	G1/2	17	60	15.1	DMC 10M-8GB-C	
	107.324.101.012	DN09	12	G1/4	14	55	8.6	DMC 12M-4GB-C	
ⓓ	107.324.101.013	DN09	12	G3/8	14	55	9.1	DMC 12M-6GB-C	
	107.324.101.014	DN09	12	G1/2	17	60	12	DMC 12M-8GB-C	
	107.324.101.015	DN09	12	G3/4	19	65	14.3	DMC 12M-10GB-C	
	107.324.101.016	DN12	16	G3/8	14	55	8.3	DMC 16M-6GB-C	
ⓔ	107.324.101.017	DN12	16	G1/2	17	60	10.4	DMC 16M-8GB-C	
	107.324.101.018	DN15	20	G1/2	17	65	10.3	DMC 20M-8GB-C	
	107.324.101.019	DN15	20	G3/4	19	65	11.1	DMC 20M-12GB-C	
	107.324.101.020	DN20	25	G3/4	19	70	10.5	DMC 25M-12GB-C	
ⓕ	107.324.101.021	DN20	25	G1	21	70	10.5	DMC 25M-16GB-C	
ⓖ	107.324.101.022	DN20	25	G1 1/4	23	75	12.9	DMC 25M-20GB-C	
ⓗ	107.324.101.023	DN20	25	G1 1/2	25	80	14.5	DMC 25M-24GB-C	

Drawn for Dk-Lok  
Material: Steel  
PN needs to meet the working  
pressure of Dk-Lok products. ⓔ

ⓓ siehe Hauptzeichnung für Spezifikation  
SEE MAIN DRAWING FOR SPECIFICATION

1	023	107.324.101.023	SCREW-IN UNION	25xG1 1/2	107.324.101	Steel	0,733
1	022	107.324.101.022	SCREW-IN UNION	25xG1 1/4	107.324.101	Steel	0,543
1	021	107.324.101.021	SCREW-IN UNION	25xG1	107.324.101	Steel	0,329
1	020	107.324.101.020	SCREW-IN UNION	25xG3/4	107.324.101	Steel	0,247
1	019	107.324.101.019	SCREW-IN UNION	20xG3/4	107.324.101	Steel	0,223
1	018	107.324.101.018	SCREW-IN UNION	20xG1/2	107.324.101	Steel	0,173
1	017	107.324.101.017	SCREW-IN UNION	16xG1/2	107.324.101	Steel	0,125
1	016	107.324.101.016	SCREW-IN UNION	16xG3/8	107.324.101	Steel	0,094
1	015	107.324.101.015	SCREW-IN UNION	12xG3/4	107.324.101	Steel	0,195
1	014	107.324.101.014	SCREW-IN UNION	12xG1/2	107.324.101	Steel	0,126
1	013	107.324.101.013	SCREW-IN UNION	12xG3/8	107.324.101	Steel	0,084
1	012	107.324.101.012	SCREW-IN UNION	12xG1/4	107.324.101	Steel	0,076
1	011	107.324.101.011	SCREW-IN UNION	10xG1/2	107.324.101	Steel	0,116
1	010	107.324.101.010	SCREW-IN UNION	10xG3/8	107.324.101	Steel	0,069
1	009	107.324.101.009	SCREW-IN UNION	10xG1/4	107.324.101	Steel	0,056
1	008	107.324.101.008	SCREW-IN UNION	8xG1/2	107.324.101	Steel	0,112
1	007	107.324.101.007	SCREW-IN UNION	8xG3/8	107.324.101	Steel	0,063
1	006	107.324.101.006	SCREW-IN UNION	8xG1/4	107.324.101	Steel	0,043
1	005	107.324.101.005	SCREW-IN UNION	8xG1/8	107.324.101	Steel	0,031
1	004	107.324.101.004	SCREW-IN UNION	6xG1/2	107.324.101	Steel	0,111
1	003	107.324.101.003	SCREW-IN UNION	6xG3/8	107.324.101	Steel	0,063
1	002	107.324.101.002	SCREW-IN UNION	6xG1/4	107.324.101	Steel	0,045
1	001	107.324.101.001	SCREW-IN UNION	6xG1/8	107.324.101	Steel	0,028

QTY	SEQ NO	Material ID	Material Name	Standard or Drawing	Basic Material Material Standard	Weight GRUNET
				Dimension, Dec	D-Code XXXXXX	Main Dwg.
					Standard ISO, JIS	

Check	From	By	Check	By	Check	By	Check	By
ⓑ	7-31-70	18.07.2005	ⓒ	7-54-378	08.06.2007	ⓓ	EAAD089575	01.10.2012
	Number	Drawn date		Number	Drawn date		Number	Drawn date
							ⓔ	EAAD099104
								28.11.2019

Product: W-2S  
SCREW-IN UNION  
Einschraubverschraubung

Units: mm kg NX Basic Material Scale: 1:1 Size: A1 Page: 1/1 Material ID: 107.324.101

Net Weight: 0,733

Surface Protection: SEE GROUP 0344  
TOLERANCING PRINCIPLE: ISO8015  
GENERAL TOLERANCES ACCORDING TO ISO2768-mK

Made: 17.12.2004 wdo001 W.Doerig  
Design Group: 0333  
Appd: 28.02.2005 PST007

Copyright WInG D Gas & Diesel Ltd. All rights reserved. By taking possession of the drawing the recipient recognizes and honours these rights. Neither the whole nor any part of this drawing may be used in any way for construction, fabrication, marketing or any other purpose nor copied in any way nor made accessible to third parties without the previous written consent of WInG D Gas & Diesel Ltd.

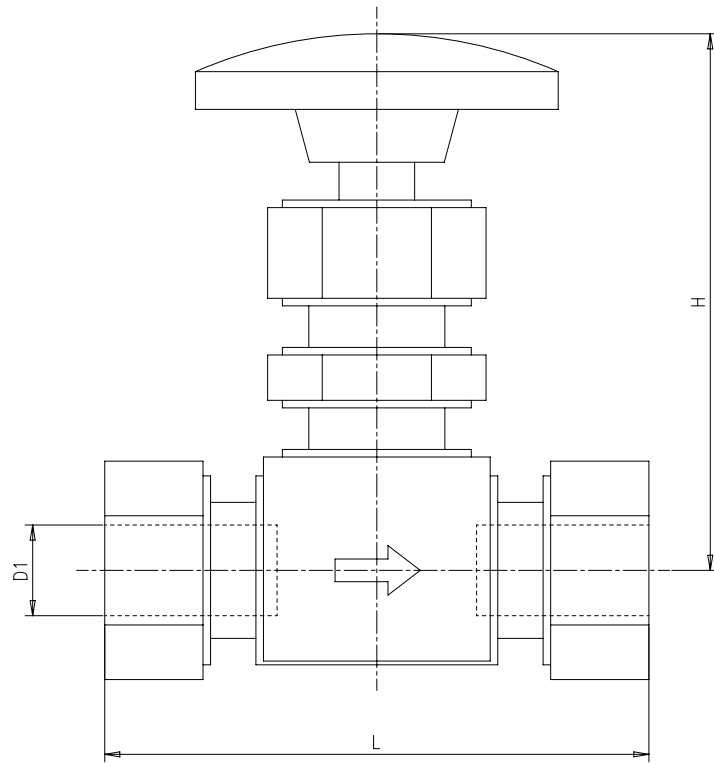

Artikel Nummer	DN	TUBE D1	L	H(open)
107.324.704.001	DN07	10	66	71
107.324.704.002	DN09	12	72	71
107.324.704.003	DN12	16	94	99
107.324.704.004	DN15	20	97	99
107.324.704.005	DN20	25	97	99
107.324.704.006	DN06	8	59,2	60

siehe Hauptzeichnung für Spezifikation  
SEE MAIN DRAWING FOR SPECIFICATION

QTY	SEQ NO	Material ID	Material Name	Dimension, Occ	Standard or Drawing	Basic Material Material Standard	Weight GR./NET
1	006	107.324.704.006	NEEDLE VALVE	DN6	107.324.704	Steel	0,304
1	005	107.324.704.005	NEEDLE VALVE	DN20	107.324.704	Steel	1,34
1	004	107.324.704.004	NEEDLE VALVE	DN15	107.324.704	Steel	1,19
1	003	107.324.704.003	NEEDLE VALVE	DN12	107.324.704	Steel	0,903
1	002	107.324.704.002	NEEDLE VALVE	DN9	107.324.704	Steel	0,495
1	001	107.324.704.001	NEEDLE VALVE	DN7	107.324.704	Steel	0,438

Modif.	Number	Drawn date	Number	Drawn date	Number	Drawn date	Number	Drawn date
B	7-61981	12.03.2008	C	EAAD700013	19.01.2011	D	EAAD083575	01.10.2012
E	EAAD096344	12.03.2021						

	Product	NEEDLE VALVE
	W-2S	Nadelventil
Units	mm kg	NX
Basic Material		
Net Weight		

SURFACE PROTECTION SEE GROUP 034.4	Made	19.05.2005	sga006	S.GASSER	Scale	2:1	Size	A2	Page	1/1	Material ID	
TOLERANCING PRINCIPLE ISO8015	Chkd			Design Group	0333		Drawing ID	107.324.704		Rev.	E	
GENERAL TOLERANCES ACCORDING TO ISO2768-mK	Appd	19.05.2005	MFR001	Frei								

## MIDS - WinGD X52DF - Cooling Water System (DG9721)

### TRACK CHANGES

DATE	SUBJECT	DESCRIPTION
2017-08-07	DRAWING SET	First web upload
2017-12-22	DAAD087048 107.413.097	System drg – new revision HT tank – replaced by DAAD052664
2018-12-12	DAAD087205 DAAD087048	Main and system drg. – new revision
2019-09-10	DAAD087048	System drg. – new revision
2020-09-02	DAAD052664 107.245.419	System drgs – new revision
2020-10-07	DAAD087205 DAAD087048 DAAD133030 DAAD101945 107.245.626 DAAD101890 DAAD065150 107.324.131 107.324.101 107.324.703	Main and system drg. – new revision
2021-02-24	107.324.101	System drg. – new revision
2021-03-30	DAAD101945 107.324.703 107.324.704	System drgs – new revision

### DISCLAIMER

© Copyright by Winterthur Gas & Diesel Ltd.

All rights reserved. No part of this document may be reproduced or copied in any form or by any means (electronic, mechanical, graphic, photocopying, recording, taping or other information retrieval systems) without the prior written permission of the copyright owner.

THIS PUBLICATION IS DESIGNED TO PROVIDE AN ACCURATE AND AUTHORITATIVE INFORMATION WITH REGARD TO THE SUBJECT-MATTER COVERED AS WAS AVAILABLE AT THE TIME OF PRINTING. HOWEVER, THE PUBLICATION DEALS WITH COMPLICATED TECHNICAL MATTERS SUITED ONLY FOR SPECIALISTS IN THE AREA, AND THE DESIGN OF THE SUBJECT-PRODUCTS IS SUBJECT TO REGULAR IMPROVEMENTS, MODIFICATIONS AND CHANGES. CONSEQUENTLY, THE PUBLISHER AND COPYRIGHT OWNER OF THIS PUBLICATION CAN NOT ACCEPT ANY RESPONSIBILITY OR LIABILITY FOR ANY EVENTUAL ERRORS OR OMISSIONS IN THIS BOOKLET OR FOR DISCREPANCIES ARISING FROM THE FEATURES OF ANY ACTUAL ITEM IN THE RESPECTIVE PRODUCT BEING DIFFERENT FROM THOSE SHOWN IN THIS PUBLICATION. THE PUBLISHER AND COPYRIGHT OWNER SHALL UNDER NO CIRCUMSTANCES BE HELD LIABLE FOR ANY FINANCIAL CONSEQUENTIAL DAMAGES OR OTHER LOSS, OR ANY OTHER DAMAGE OR INJURY, SUFFERED BY ANY PARTY MAKING USE OF THIS PUBLICATION OR THE INFORMATION CONTAINED HEREIN.