

Marine Installation Manual

X82DF-2.0

Issue **2023-03**

Winterthur Gas & Diesel Ltd. Schützenstrasse 3
Winterthur Gas & Diesel AG 8400 Winterthur
Winterthur Gas & Diesel S.A. Switzerland

Tel. +41 (0)52 264 8844
Fax +41 (0)52 264 8866
www.wingd.com

WINGD
Winterthur Gas & Diesel

© 2023 Winterthur Gas & Diesel Ltd. — All rights reserved

No part of this publication may be reproduced or copied in any form or by any means (electronic, mechanical, graphic, photocopying, recording, taping or other information retrieval systems) without the prior written permission of the copyright holder. Winterthur Gas & Diesel Ltd. makes no representation, warranty (express or implied) in this publication and assumes no responsibility for the correctness, errors or omissions of information contained herein. Information in this publication is subject to change without notice.

NO LIABILITY, WHETHER DIRECT, INDIRECT, SPECIAL, INCIDENTAL OR CONSEQUENTIAL, IS ASSUMED WITH RESPECT TO THE INFORMATION CONTAINED HEREIN. THIS PUBLICATION IS INTENDED FOR INFORMATION PURPOSES ONLY.

List of Changes

The following tables reflect the changes and updates to the contents of this document.
Minor changes in layout or language are not taken into consideration.

Revision:	06	Date of issue:	2023-03	
Location of change			Subject	
1.2.1 Engine rating field - rating points			Performance data removed from Table 1-4 (provided by GTD)	
3 Engine Installation			Whole chapter restructured	
3.1.1 Drawings and 3D CAD model availability			New design groups added from the 3D engine outline and yard connection concept	
3.10 Twin-engine propulsion			New section added	
4.2.3 The iCER drainage system			iCER drainage figures simplified with the removal of standby pumps	
4.4 Lubricating oil systems			Section updated Removal of iCAT as an option	
4.4.7 Drain tank Inclination angles			Tables 4-5, 4-6, 4-7 updated	
4.13.5 PTO application			New section added	
5.8 The intelligent combustion control			New section added	
6.2.2 Reduction of lateral vibration Electrically-driven compensator(s)			Section updated	
9.2 List of acronyms			Table 9-2 updated	

Revision:	05	Date of issue:	2022-12	
Location of change			Subject	
1 Engine Summary			All relevant iCER technology content updated Principle engine dimensions and weights removed (shown in Chapter 3)	
3.1.2 Crane requirements			Crane hoisting speed updated and horizontal speed added	
3.2.3 Ancillary systems design parameters			Exhaust gas back pressure specifications updated	
3.4.2 Minimum requirements for escape routes			Minimum requirements for escape routes on the platforms updated	
4.2.4 The SAC wetting system			New section added	
4.9.5 The SAC washing system			New section added	

Revision:	04	Date of issue:	2022-09	
Location of change			Subject	
1 Engine Summary			Pilot fuel energy share updated Transfer between operating modes updated	
1.2.2 Principal engine dimensions and weights			Figure 1-2 updated	
1.3.3 Operation in a mixed fuel mode Combustion stability mode			Emission standard for NO _x certification updated to Tier III for CSM	

Revision:	04	Date of issue:	2022-09	
Location of change			Subject	
3.1 Engine dimensions and masses			Figure 3-1 updated	
3.2.3 Ancillary systems design parameters			Section update of exhaust gas back pressure requirements	
4.2.3 The iCER drainage system			Section updated to include iCER sludge amount and handling	
4.2.4 The iCER exhaust gas system			Section updated to include further details for the purge line	

Revision:	03	Date of issue:	2022-06	
Location of change			Subject	
1 Engine Summary			All relevant iCER technology content updated	
2.7 Prohibited operation area			New section of prohibited operation area added	
4.1 Twin-engine installation			Table 4-1 updated	
4.2 The iCER technology			Whole section restructured and content updated	
4.13.5 PTO testing			PTO testing information added	

Revision:	02	Date of issue:	2022-02	
Location of change			Subject	
1 Engine Summary			Restructured to include the iCER diesel Tier III mode option	
3.5 Engine foundation and seating			Whole section restructured and content updated	
4.1 Twin-engine installation			Table 4-1: The EGC circulation water treatment system for the iCER diesel Tier III mode added	
4.2 The iCER			The iCER diesel Tier III mode option added	
4.4.5 Cylinder lubricating oil system			Heating cable specification in Table 4-3 updated	
4.4.7 Drain tank Inclination angles			Tables 4-4, 4-5, 4-6 updated	
4.5.8 Fuel gas venting Ventilation of double-wall fuel gas piping			Rules for the installation of the ventilation fan refined and updated	
4.9.4 The iCER drainage system			Restructured to include the iCER diesel Tier III mode option and information updated for handling of bleed-off water	
4.10 Exhaust gas system Explosion relief devices The iCER exhaust gas system			Section updated to align with current regulations. The iCER diesel Tier III mode option added and iCER arrangement updated.	
4.12.2 Fluid velocities and flow rates			Further information added	
5.7 WinGD Integrated Digital Expert (WiDE)			General update of the product description and customers' benefits. Figure 5-8 updated.	
7 Engine Emissions			Exhaust gas emissions comparisons and calculations criteria added. Regulations re-fined and updated.	
7.1.2 iCER diesel Tier III mode			The iCER diesel Tier III mode option added	
9.2 List of acronyms			Table 9-2 updated	

Revision:	01	Date of issue:	2021-11	
Location of change			Subject	
1.1 Engine capability and features			Table 1-3 added to list the iCER system features and components	
1.3.1 Operation in gas mode Shaft power meter requirements			Subsection retitled and content added	
3.1.2 Crane requirements			Crane speed information updated	
3.2.4 Electrical power requirement			Table 3-2 updated	
4.13 PTO, PTI, PTH and primary generator applications			PTI option on free end removed	
4.13.2 Arrangements for PTO, PTI, PTH and primary generator			Figure 4-61 and Table 4-17 updated	
5.4.2 Recommended manoeuvring characteristics FPP manoeuvring steps and warm-up times			Correction to note: Acceleration above FULL SEA 2 speed included	
6.2.2 Reduction of lateral vibration			Section restructured and content updated	

Revision:	--	Date of issue:	2021-07	
Location of change			Subject	
--			First edition	

Table of Contents

List of Changes	1
0 Preface	0-1
Marine Installation Manual Introduction	0-1
Explanation of symbols in this Marine Installation Manual	0-2
Marine Installation Drawing Set	0-3
General Technical Data (GTD)	0-4
Operation and maintenance manuals	0-4
1 Engine Summary	1-1
1.1 Engine capability and features	1-1
Special engine features	1-3
1.2 Primary engine data	1-5
1.2.1 Engine rating field - rating points	1-6
1.3 Fuel operating modes	1-7
1.3.1 Operation in gas mode.	1-9
Shaft power meter requirements	1-10
The iCER system	1-10
1.3.2 Operation in diesel mode.	1-12
1.3.2 The Flex system	1-12
iCER diesel Tier III mode	1-13
1.3.3 Operation in a mixed fuel mode	1-14
Combustion stability mode.	1-14
Fuel sharing mode	1-15
1.3.4 Changeover between operating modes	1-17
Transfers and gas trips	1-17
2 Engine Power and Speed	2-1
2.1 Introduction to power and speed	2-1
2.2 Engine rating field	2-1
Rating points	2-2
2.3 Influence of propeller diameter and revolutions	2-2
2.4 Power range	2-3
Propeller curves and operational points	2-3
Sea trial power	2-4
Sea margin	2-4
Light running margin	2-5
Continuous service rating	2-5
Engine margin	2-5
Contracted maximum continuous rating	2-5
2.5 Power range limits	2-6
2.6 Power range limits with a power take-off installation for a FPP	2-10
PTO incorporation of Method 1	2-10
PTO incorporation of Method 2	2-12
2.7 Prohibited operation area	2-13
Prohibited operation area for different speed rated engines	2-15

3	Engine Installation	3-1
3.1	Engine dimensions and masses	3-1
3.1.1	Drawings and 3D CAD model availability	3-2
3.1.2	Dismantling dimensions	3-2
3.1.3	Crane requirements	3-2
3.1.4	Thermal expansion between the turbocharger and exhaust gas piping	3-3
3.1.5	Content of fluids in the engine	3-4
3.2	Engine outline views	3-5
3.3	Platform outline views	3-6
3.3.1	Minimum requirements for escape routes	3-6
3.4	Engine foundation and seating	3-7
3.4.1	Engine load and force transmission	3-7
3.4.2	Engine foundation layouts	3-7
3.4.3	Engine installation and fixation	3-8
3.5	Assembly	3-11
3.5.1	Assembly of subassemblies	3-11
3.5.2	Installation of a complete engine	3-12
3.5.3	Installation of an engine from assembled subassemblies	3-12
3.5.4	Installation of an engine in ship on slipway	3-12
3.6	Engine and shaft alignment	3-13
3.6.1	Instructions and limits	3-13
3.6.2	Tools	3-13
3.7	Engine coupling	3-14
3.7.1	Design	3-14
3.7.2	Machining and fitting of coupling bolts	3-14
3.7.3	Tightening	3-14
3.7.4	Installation drawing	3-14
3.8	Engine stays	3-15
3.9	Propulsion shaft earthing	3-16
3.9.1	Preventive action	3-16
3.9.2	Earthing device	3-16
3.10	Twin-engine propulsion	3-19
3.11	Fire protection	3-20
3.12	Conditions and requirements	3-21
3.12.1	Pressure and temperature ranges	3-21
3.12.2	Operating conditions	3-21
3.12.2	Reference conditions	3-21
3.12.2	Design conditions	3-21
3.12.3	Ancillary systems design parameters	3-22
3.12.3	Description of the back pressure specifications	3-22
3.12.4	Electrical power requirement	3-23
4	Ancillary Systems	4-1
4.1	Twin-engine installation	4-2
4.2	The iCER technology	4-4
4.2.1	The iCER description	4-5
4.2.2	The EGC circulation water system	4-6
4.2.3	The iCER drainage system	4-8
	Arrangement of the iCER drainage system for installations which run the iCER system exclusively in gas mode	4-9
	Unified arrangements of the iCER drainage system, valid for all iCER operating mode options	4-11

4.2.4	The SAC wetting system	4-20
4.2.5	The iCER exhaust gas system	4-22
4.2.6	Heat recovery (economiser)	4-25
	Different routing concepts	4-25
	Additional economiser (optional)	4-27
4.3	Cooling water system	4-28
4.3.1	Low-temperature circuit	4-29
	Arrangement 1	4-30
	Arrangement 2	4-30
	Arrangement 3	4-31
	Low-temperature circuit components	4-32
4.3.2	High-temperature circuit	4-33
	High-temperature circuit components	4-34
4.3.3	Pre-heating	4-37
	Pre-heating from cooling water systems	4-37
	Pre-heating by direct water circulation	4-37
4.3.4	Freshwater generator	4-38
4.3.5	Cooling water treatment	4-39
4.3.6	General recommendations for the cooling water system design	4-40
4.3.7	The EGC circulation water system	4-40
4.4	Lubricating oil systems	4-41
4.4.1	Lubricating oil requirements	4-41
4.4.2	Main lubricating oil system	4-41
	Main lubricating oil system components	4-42
	System oil	4-44
4.4.3	Flushing the lubricating oil system	4-44
4.4.4	Lubrication for turbochargers	4-44
4.4.5	Cylinder lubricating oil system	4-45
	Service tank and storage tank	4-47
	Electrical trace heating for ship side cylinder lubricating oil piping	4-48
4.4.6	Maintenance and treatment of lubricating oil	4-50
4.4.7	Drain tank	4-51
4.5	Fuel gas system	4-56
4.5.1	Safety considerations	4-56
4.5.2	Operating principles	4-57
	The lean-burn concept	4-57
4.5.3	Gas specifications	4-59
	Methane number dependent engine output	4-60
	Methane number calculation	4-60
4.5.4	Fuel gas supply system	4-61
	Master gas fuel engine valve	4-61
	Tank type	4-61
	Supplying fuel gas	4-64
	Re-liquefaction process	4-67
4.5.5	Fuel gas supply pressure	4-69
4.5.6	On-engine integrated gas pressure regulation unit	4-73
4.5.7	Off-engine gas valve unit	4-75
4.5.8	Fuel gas venting	4-77
	Ventilation of double-wall fuel gas piping	4-77
4.5.9	Purging by inert gas	4-78
4.5.10	Fuel gas leak test	4-81
4.6	Pilot fuel oil system	4-82

4.7	Fuel oil system	4-85
4.7.1	Fuel oil system components	4-85
	Feed pump — Low-pressure fuel oil	4-86
	Pressure regulating valve	4-87
	Mixing unit	4-87
	Booster pump — High-pressure fuel oil	4-89
	End-heater	4-89
	Viscometer	4-90
	MDO/MGO heat exchanger	4-90
	Fuel oil filters — Arrangement 'A'	4-91
	Fuel oil filter — Arrangement 'B'	4-96
4.7.2	Fuel oil system with only MDO/MGO or MGO	4-97
	Fuel oil feed pump	4-98
	Fuel oil heat exchanger	4-98
	Fuel oil filter	4-98
4.7.3	Flushing the fuel oil system	4-98
4.7.4	Fuel oil treatment	4-99
	Settling tanks	4-99
	Service tanks	4-99
	Centrifugal fuel oil separators	4-99
4.7.5	Pressurised fuel oil system	4-101
4.7.6	Fuel oil specification	4-101
4.7.7	Fuel oil viscosity-temperature dependency	4-102
4.8	Air supply system	4-103
4.8.1	Capacities of air compressor and receiver	4-104
4.8.2	System specification	4-104
	Starting air compressors	4-104
	Starting air receivers	4-104
4.8.3	Control air	4-105
4.8.4	Service and working air	4-105
4.9	Leakage collection system and washing devices	4-106
4.9.1	Sludge oil trap solutions	4-106
	General description of the sludge oil trap	4-106
	Solution 1: A constantly-drained sludge oil trap with separate sludge accumulation	4-107
	Solution 2: A manually bottom-drained sludge oil trap	4-108
	Solution 3: An automatically bottom-drained sludge oil trap	4-110
4.9.2	Draining of exhaust uptakes	4-112
4.9.3	Air vents	4-112
4.9.4	The iCER drainage system	4-112
4.9.5	The SAC washing system	4-113
	Offline SAC washing system (external system)	4-113
4.10	Exhaust gas system	4-114
4.10.1	The iCER exhaust gas system	4-115
4.10.2	Heat recovery (economiser)	4-115
4.11	Engine room ventilation	4-116
4.11.1	Ventilation requirements	4-116
4.11.2	Ventilation arrangement	4-117
	Arrangement 1 — Engine room ventilation system	4-118
	Arrangement 2 — Direct engine ventilation system	4-119
4.11.3	Air intake quality	4-120
4.11.4	Outside ambient air temperature	4-122

4.12	Piping	4-123
4.12.1	Pipe connections	4-123
4.12.2	Fluid velocities and flow rates	4-123
4.13	PTO, PTI, PTH and primary generator applications	4-124
4.13.1	Requirements	4-124
4.13.2	Arrangements for PTO, PTI, PTH and primary generator	4-124
4.13.3	Application constraints	4-126
4.13.4	Service conditions	4-128
4.13.5	PTO application	4-129
	Further services for evaluation of engine performance and X-EL advisory services	4-130
4.13.6	PTO testing	4-131
5	Engine Automation	5-1
5.1	DENIS	5-1
5.2	DENIS concept	5-2
5.2.1	Interface definition	5-2
5.2.2	Approved propulsion control systems	5-2
5.3	DENIS specification	5-3
5.3.1	DENIS interface specification	5-3
5.3.2	DENIS propulsion control specification	5-3
5.4	Propulsion control systems	5-4
5.4.1	Functions of the propulsion control system	5-6
	Remote control system	5-6
	Safety system	5-6
	Telegraph system	5-6
	Local manual control	5-6
	ECR manual control panel	5-6
	Options	5-7
5.4.2	Recommended manoeuvring characteristics	5-8
5.5	Alarm and monitoring system	5-10
5.5.1	Integrated solution	5-10
5.5.2	Split solution	5-10
5.6	Alarm sensors and safety functions	5-11
5.6.1	Signal processing	5-11
5.6.2	Requirements of WinGD and classification societies	5-11
5.7	WinGD Integrated Digital Expert (WiDE)	5-12
5.7.1	Data collection	5-12
5.7.2	Engine diagnostic module	5-13
5.7.3	The WiDE installation process	5-14
5.8	The intelligent combustion control	5-15
5.8.1	ICC control functions	5-15
5.8.2	ICC activation modes	5-15
5.8.3	ICC data	5-16
6	Engine Dynamics	6-1
6.1	External mass forces and moments	6-2
6.1.1	Balancing of mass forces and moments	6-2
6.1.2	Countermeasure for second order vertical mass moments	6-3
	Electrically-driven compensator (external compensator)	6-3
	Power related unbalance	6-4

6.2	External lateral forces and moments	6-5
6.2.1	Lateral vibration types	6-6
	H-type vibration	6-6
	X-type vibration	6-6
6.2.2	Reduction of lateral vibration	6-7
	Lateral stays	6-7
	Determining the minimum number of required lateral stays	6-9
	Electrically-driven compensator(s)	6-12
6.3	Longitudinal vibration (pitching)	6-12
6.4	Torsional vibration	6-13
6.4.1	Reduction of torsional vibration	6-13
	Low-energy vibrations	6-14
	High-energy vibrations	6-14
6.4.2	PTO/PTI systems effect on torsional vibration	6-15
6.5	Axial vibration	6-16
	Reduction of axial vibration	6-16
6.6	Whirling vibration	6-17
6.7	Hull vibration	6-18
6.8	Countermeasures for dynamic effects	6-19
6.8.1	External mass moments and vibrations	6-19
6.8.2	Synchro-Phasing System in twin engines	6-20
	Concept	6-20
	Components and control	6-21
	Operating modes and restrictions	6-22
6.9	Order forms for vibration calculation & simulation	6-23
7	Engine Emissions	7-1
7.1	Exhaust gas emissions	7-1
7.1.1	Regulation and calculation criteria for NOx emissions	7-2
7.1.2	Regulation and calculation criteria for SOx emissions	7-3
7.1.3	Regulation and calculation criteria for CO2 emissions	7-4
7.1.4	PM emissions	7-5
7.1.5	iCER diesel Tier III mode	7-5
7.2	Engine noise	7-6
7.2.1	Air-borne noise	7-6
7.2.2	Exhaust noise	7-8
7.2.3	Structure-borne noise	7-10
8	Engine Dispatch	8-1
8.1	Engines to be transported as part assemblies	8-1
8.2	Protection of disassembled engines	8-1
8.3	Removal of rust preventing oils after transport	8-1
8.3.1	Internal parts	8-1
8.3.2	External parts	8-1
9	Appendix	9-1
9.1	Classification societies	9-1
9.2	List of acronyms	9-2
9.3	SI dimensions for internal combustion engines	9-5
9.4	Approximate conversion factors	9-7

List of Tables

1-1	X82DF-2.0 summary values for Maximum Continuous Rating (MCR)	1-1
1-2	Principal engine features and technologies	1-3
1-3	The iCER technology	1-4
1-4	Rating points	1-6
1-5	Approximate fuel split (energy-based) for different operating modes over load range	1-8
1-6	Shaft power meter parameters	1-10
2-1	Line 5 coefficients	2-8
2-2	Line 6 coefficients	2-9
2-3	Line 10 coefficients	2-11
3-1	Engine dimensions and masses	3-1
3-2	Design groups of shipyard drawings and 3D CAD models	3-2
3-3	Advantages and disadvantages for the standard and narrow engine foundation layouts	3-8
3-4	Recommended quantities of fire extinguishing medium	3-20
3-5	Electrical power requirement	3-23
4-1	Common and independent systems in twin-engine installations	4-2
4-2	Chemicals required for treatment of the EGC circulation water	4-12
4-3	Recommended specifications for raw water	4-39
4-4	Heating cable specification	4-48
4-5	Minimum inclination angles for full operability of the engine (1)	4-53
4-6	Minimum inclination angles for full operability of the engine (2)	4-54
4-7	Minimum inclination angles for full operability of the engine (3)	4-55
4-8	Gas specifications	4-59
4-9	Purity of inert gas (engines with iGPR)	4-79
4-10	Purity of inert gas (engines with GVU)	4-79
4-11	Specification of the pilot fuel oil filter on the system side	4-84
4-12	Specification of automatic self-cleaning filter in feed system	4-93

4-13	Specification of automatic self-cleaning filter in booster system	4-94
4-14	Specification of duplex filter in booster system	4-95
4-15	Control air flow capacities	4-105
4-16	Guidance for air filtration	4-120
4-17	PTO/PTI/PTH arrangements for the WinGD X82DF-2.0	4-126
4-18	Possible options for the WinGD X82DF-2.0	4-126
4-19	Influence of options on engineering	4-127
5-1	Suppliers of remote control systems	5-4
5-2	Recommended manoeuvring steps and warm-up times for FPP	5-9
5-3	Additional class requirements for alarm sensors and safety functions	5-11
6-1	Countermeasures for external mass moments	6-19
6-2	Countermeasures for lateral and longitudinal vibrations	6-19
6-3	Countermeasures for torsional and axial vibrations of the shafting	6-19
9-1	List of classification societies	9-1
9-2	List of acronyms	9-2
9-3	SI dimensions	9-5
9-4	Conversion factors	9-7

List of Figures

0-1	GTD screenshot	0-4
1-1	Power/speed range of the WinGD X-DF engines	1-5
1-2	Operating modes of the X-DF2.0 engine	1-7
1-3	Gas mode operation	1-9
1-4	The iCER system with the exhaust gas return pipe routed to the turbocharger connection from below	1-11
1-5	The Flex system parts	1-12
1-6	Diesel fuel ratio during active CSM	1-14
1-7	Fuel sharing mode — available operating window	1-15
1-8	Fuel sharing mode — energy amount of different ratios of fuel	1-16
1-9	If FSM is not contracted, the fuel transfers and gas trips	1-17
1-10	If FSM is contracted, the fuel transfers and gas trips	1-18
2-1	Rating field for the X82DF-2.0	2-1
2-2	Propeller curves and operational points	2-4
2-3	Power range limits	2-6
2-4	Power range diagram of an engine with a PTO	2-10
2-5	Power range limits for PTO operation — Method 1	2-11
2-6	Power range limits for PTO operation — Method 2	2-12
2-7	The prohibited operation area (CMCR speed = R1—R2)	2-13
2-8	Calculating the prohibited operation area for the CMCR speed	2-15
2-9	The prohibited operation area (CMCR speed = 85% of R1—R2)	2-16
2-10	The prohibited operation area (CMCR speed = R3—R4)	2-17
3-1	Engine dimensions	3-1
3-2	Thermal expansion, dim. X, Y, Z	3-3
3-3	Minimum requirements for headroom	3-6
3-4	Force transmission to the engine foundation	3-7
3-5	A comparison of the standard and narrow engine foundation layout	3-7
3-6	Foundation bolting	3-9

3-7	Welded type	3-9
3-8	Side stopper installation arrangement	3-10
3-9	Proposed designs for water-tight bolting	3-10
3-10	Typical shaft earthing arrangement	3-17
3-11	Typical shaft earthing with condition monitoring facility	3-18
3-12	Example of a shaft-locking device	3-19
4-1	LT cooling water system for twin-engine installation	4-3
4-2	Overview of the components for the iCER system	4-4
4-3	The iCER system with the exhaust gas return pipe routed to the turbocharger connection from below	4-5
4-4	The EGC circulation water system	4-6
4-5	The iCER drainage system for installations which run the iCER system exclusively in gas mode	4-9
4-6	The iCER drainage system valid for all iCER operating mode options	4-11
4-7	A new variant of the unified iCER drainage system	4-14
4-8	The unified iCER drainage system for twin-engine installations	4-16
4-9	The unified iCER drainage system with a dedicated water treatment system for EGC circulation water refreshing and for bleed-off water cleaning	4-17
4-10	The unified iCER drainage system with a dedicated water treatment system for EGC circulation water cleaning and for bleed-off water cleaning	4-18
4-11	The SAC wetting system with the clean water holding tank arrangement	4-20
4-12	The SAC wetting system with the SAC wetting buffer tank arrangement	4-20
4-13	The iCER exhaust gas system with the exhaust gas return pipe routed to the turbocharger connection from below	4-22
4-14	Example of an exhaust gas piping arrangement	4-24
4-15	The short route arrangement	4-25
4-16	The long route arrangement	4-26
4-17	Arrangement of the additional economiser (Source: Alfa Laval)	4-27
4-18	Separate HT cooling water circuit	4-28

4-19	LT cooling water circuit — Single set-point temperature	4-30
4-20	LT cooling water circuit — Dual set-point temperatures	4-30
4-21	Separate SAC and LT cooling circuits	4-31
4-22	HT cooling water circuit	4-34
4-23	Pre-heating power requirement per cylinder.	4-38
4-24	Lubricating oil system	4-41
4-25	Dual cylinder lubricating oil installation, enabling independent gas and liquid fuel (maximum 0.50% m/m sulphur) operation with a manual changeover valve	4-46
4-26	Cylinder lubricating oil system for fuel with ultra low sulphur content (maximum 0.10% m/m sulphur) or alternatively, a single grade cylinder lubricating oil is applied for fuel with very low sulphur content (maximum 0.50% m/m sulphur)	4-47
4-27	Trace heating cable arrangement.	4-48
4-28	Dimensioning and filling process of lubricating oil drain tank	4-51
4-29	Arrangement of vertical lubricating oil drains for 6-cylinder engines	4-52
4-30	Lean burn with pilot ignition.	4-58
4-31	Lean-burn operation window	4-58
4-32	Maximum achievable power	4-60
4-33	Section view of an integrated membrane tank	4-61
4-34	Section view of a free-standing Type A tank.	4-62
4-35	Section view of a free-standing Type B tank of moss design	4-62
4-36	Section view of different free-standing Type C tanks installed below the deck.	4-63
4-37	Type C tank on the deck of a vessel	4-63
4-38	Pressurised Type C tank solution with NBOG handling by the gensets	4-65
4-39	Pressurised Type C tank solution with NBOG handling by the gensets and the main engine	4-66
4-40	Non-pressurised tank solution, drawn for an LNGC	4-66
4-41	An LNG sub-cooler within an integrated tank.	4-68
4-42	Design fuel gas supply pressure requirements	4-69

4-43	Fuel gas supply pressure control at the engine inlet (engines with iGPR)	4-71
4-44	Fuel gas supply pressure control at the GVU inlet (engines with GVU)	4-71
4-45	Fuel gas pressure level definitions	4-72
4-46	Fuel gas supply system with the iGPR	4-73
4-47	The GVU-OD™ from Wärtsilä	4-75
4-48	The GVU-ED™ from Wärtsilä	4-76
4-49	Gas leak test sequence (engines with iGPR)	4-81
4-50	Gas leak test sequence (engines with GVU)	4-81
4-51	Pilot fuel oil system	4-82
4-52	Pilot fuel high-pressure system	4-83
4-53	Fuel oil system	4-85
4-54	Mixing unit	4-88
4-55	Mesh size difference between absolute and nominal.	4-91
4-56	Fuel oil filter arrangement 'A'	4-92
4-57	Fuel oil filter arrangement 'B'	4-96
4-58	Fuel oil system — Arrangement with only MDO/MGO or MGO	4-97
4-59	Fuel oil viscosity-temperature diagram	4-102
4-60	Air supply system	4-103
4-61	Design proposal of WinGD's sludge oil trap	4-108
4-62	Design proposal of a manually bottom-drained sludge oil trap	4-109
4-63	Design proposal of an automatically bottom-drained sludge oil trap	4-111
4-64	Arrangement of automatic water drain	4-112
4-65	Offline SAC washing system (external system)	4-113
4-66	Determination of exhaust pipe diameter	4-114
4-67	Ventilation system arrangement 1 — Engine room ventilation system	4-118
4-68	Ventilation system arrangement 2 — Direct engine ventilation system	4-119
4-69	Air filter size (example for 9-cyl. engine)	4-121

4-70	Arrangements for PTO, PTI, PTH	4-125
4-71	FPP with mandatory frequency converter	4-128
4-72	Maximum power increase rate for PTO application in gas mode	4-129
4-73	Maximum power decrease rate for PTO application in gas mode	4-130
5-1	Engine automation architecture	5-1
5-2	Engine management and automation concept	5-2
5-3	Remote control system	5-5
5-4	Propulsion control	5-7
5-5	Manoeuvring speed/power settings for FPP/ CPP installations	5-8
5-6	Full sea load steps in FPP load-up program	5-9
5-7	The WiDE data collection and analysis process	5-12
5-8	The WiDE installation process	5-14
5-9	The ICC system	5-16
6-1	External mass forces and moments	6-2
6-2	Locating an electrically-driven compensator	6-3
6-3	Forces through the engine	6-5
6-4	Lateral vibration — X-type and H-type	6-6
6-5	Lateral stays shifting the resonance frequency above nominal speed	6-7
6-6	General arrangement of hydraulic type stays for one-side installation	6-8
6-7	General arrangement of hydraulic type stays for both-side installation	6-8
6-8	Twin-engine installations with two standard engines	6-10
6-9	Variants of twin-engine installations with a standard and a left engine	6-10
6-10	Engine stays arrangement on the exhaust side	6-11
6-11	Engine stays arrangement on the engine's fuel side	6-11
6-12	Engine stays arrangement on both engine sides	6-12
6-13	Vibration dampers (spring type and viscous type)	6-15
6-14	Example of axial vibration damper	6-16

6-15	Resulting vibration from SPS combinations	6-20
6-16	Synchro-Phasing system	6-21
7-1	Emissions comparison between X-DF2.0, X-DF and diesel engines ..	7-1
7-2	Speed dependent maximum allowable average of NOx emissions ...	7-2
7-3	Sulphur limits introduced by IMO according to MARPOL Annex VI ...	7-3
7-4	Sound pressure level at 1 m distance from engine	7-7
7-5	Exhaust noise reference point	7-8
7-6	Sound pressure level at funnel top of exhaust gas system	7-9
7-7	Structure-borne noise level at engine feet vertical	7-10

0 Preface

WinGD provides a range of manuals and tools to help its customers at all stages of a project. From design engine to installation and maintenance, WinGD provides extensive help and support.

This manual is the initial guide to the installation process for this specific engine, providing an overview of the different topics which need to be considered in the project and the engine installation phase. In parallel to this manual are the drawing sets and software tools which provide detailed values and ranges to help finalise the installation process. Finally, each engine has its own range of operation and maintenance manuals to support the complete life cycle of the engine, following the design and installation phase.

Marine Installation Manual Introduction

The Marine Installation Manual (MIM) contains all the necessary information that must be considered in the engine design and installation phase. The MIM provides an essential overview for project and design personnel. Each chapter contains detailed information for design engineers and naval architects, enabling them to optimise plant components and machinery space, and to carry out installation design work.

The MIM is not to be considered as a specification. The build specification is subject to the laws of the legislative body of the country of registration and the rules of the classification society selected by the owners. Also, guidelines for the installation and operation from the makers' side must be observed. Furthermore, the engine requirements and any third-party maker requirements must be fulfilled. System components are not the responsibility of WinGD.

The content of this document is subject to the understanding that WinGD has prepared the data and information herein with care and to the best of knowledge. However, the data and information contained in this document is subject to revision without notice. WinGD does not assume any liability with regard to unforeseen variations in accuracy thereof or for any consequences arising therefrom.

Reference to compliance

All data are related to engines compliant with the regulations of:

- Revised MARPOL Annex VI
- NO_x Technical code 2008

Reference information

Specific values and design recommendations are included in the Marine Installation Drawing Set (MIDS), while the engine performance data is provided by the General Technical Data (GTD). This chapter explains both tools.

*Explanation of symbols in this Marine Installation Manual***Cross references**

Cross references are written in blue. They lead to another section, table or figure in this manual and can be activated by a mouse click. They comprise the number of the respective figure or table, or the section title, followed by the page symbol introducing the page number.

Example: [Table 4-5](#), [4-53](#)

Notes

They either provide additional information which is considered important or they draw the reader's attention to special facts.

Example:

NOTE

The illustration does not necessarily represent the actual configuration or the stage of development of the engine concerned.

Weblinks

Weblinks are written in blue italics. They are preceded by the following symbols and refer to:



- Drawings of the Marine Installation Drawing Set (MIDS), which are provided on the WinGD webpage.

Example: *MIDS*



- Documents like shipyard installation instructions and system concept guidance, which are provided on the WinGD webpage.

Example: *Fuel oil treatment*



- General Technical Data (GTD). This is an application provided on the WinGD webpage.

Link: *GTD*

Marine Installation Drawing Set

The Marine Installation Drawing Set (MIDS) is part of the documentation provided for licensees, shipyards and operators. The MIDS is to be referred to in conjunction with the MIM during engine installation and operation.

The MIDS documentation includes drawings and guidelines that provide:

- Engine-ship interface specifications
- General installation / system proposals

Engine design groups

The MIDS covers Design Groups (DG) **97xx**:

9707	Engine Alignment Record Sheets
9709	Engine Alignment
9710	Engine Seating / Foundation
9710-01	Tool Engine Alignment
9715	Engine Stays
9721	Cooling Water Systems
9722	Lubricating Oil Systems
9723	Fuel Oil System
9724	Leakage Collection / Washing System
9725	Air Supply System
9726	Exhaust System
9727	Fuel Gas System
9730	Various Installation Items ¹⁾

Links to complete drawing packages

The latest versions of the drawing packages which are relevant for the present MIM are provided on the WinGD webpage under the following links:

- Marine installation drawings:
[*MIDS - complete package*](#)
- Shipyard installation instructions and system concept guidance:
[*Concept guidance and instructions - complete package*](#)

1) A key for MIDS *Piping Symbols* is included in the design group 'Various Installation Items' (DG 9730) for reference.

General Technical Data (GTD)

The General Technical Date (GTD) is an application that is used to calculate the engine performance data such as temperatures, flow rates, and consumption figures based on the selected engine rating and tuning options. The output generated by the GTD is used to design the marine propulsion plant and can be used for all engines within the WinGD portfolio.

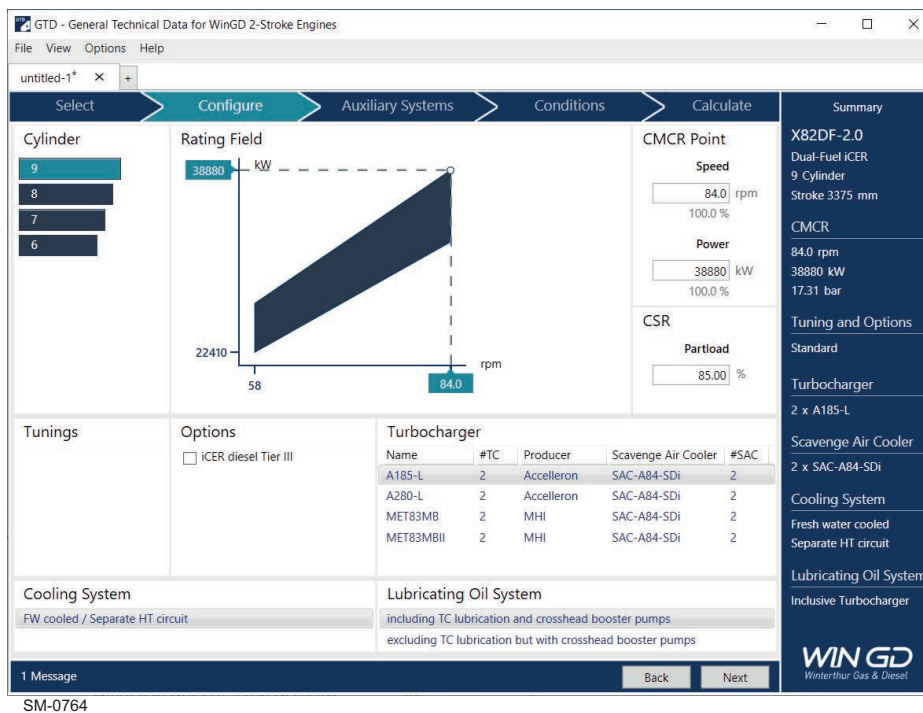

Figure 0-1 GTD screenshot

GTD output

In addition to the output of characteristic parameters in the whole rating field of an engine, the GTD application also delivers data on the capacities of coolers, pumps, starting air bottles and air compressors. It provides additional information on engine radiation, the power requirement for ancillary systems, and output data suitable for estimating the size of ancillary equipment. Furthermore, the GTD can generate data such as the available components and options for specification and engine rating. In addition to the standard output for ISO reference and design conditions, further operating conditions for which information is required can be defined.



The GTD application is accessible on the WinGD Customer Portal or on the WinGD webpage using the following link:

<https://www.wingd.com/en/media/general-technical-data>

Operation and maintenance manuals

After the successful completion of the engine design and installation phase, additional documents are available to support the complete lifecycle of each engine. This additional documentation is available on the WinGD Customer Portal and this includes the following documents:

- The Instruction Manual (IM)
- The Spare Parts Catalogue (SPC)

1 Engine Summary

The WinGD X82DF-2.0 is a camshaftless, low-speed, reversible and rigidly direct-coupled two-stroke engine. It features a low-pressure gas operation and a common-rail injection system combined with the Intelligent Control by Exhaust Recycling (iCER) system.

iCER operating mode options

The WinGD X82DF-2.0 is available in two variants:

- iCER gas mode
- iCER gas and diesel Tier III mode

The iCER gas mode improves the gas mode performance to significantly reduce the emissions, especially methane emissions. Alternatively, the iCER diesel Tier III mode additionally provides Tier III compliance while operating with diesel fuel.

Table 1-1 X82DF-2.0 summary values for Maximum Continuous Rating (MCR)

Bore:	820 mm
Stroke:	3,375 mm
Number of cylinders:	6 to 9
Power (MCR):	4,320 kW/cyl
Speed (MCR):	84 rpm
Mean effective pressure:	17.3 bar
Stroke/bore ratio:	4.12

Engine dimensions and masses

The details about sizing, specific dimensions and masses are provided in section [3.1 Engine dimensions and masses](#),  3-1.

This chapter introduces the engine. It focuses on all aspects of the engine that may be different from other engines. This chapter also highlights the suitability of the engine.

1.1 Engine capability and features

This engine type is designed to run on gas fuel or on liquid fuel. The gas fuel is evaporated Liquefied Natural Gas (LNG). The liquid fuel comprises a wide range of marine fuels such as Marine Gas Oil (MGO) and Heavy Fuel Oil (HFO) of varying qualities. This fuel flexibility is made possible by WinGD’s low-pressure technology. The operating mode can be changed while the engine is running without any loss of power.

Gas mode: Certified Tier III

In gas mode the main fuel is natural gas. The natural gas is injected into the engine at low pressure. The gas fuel is ignited by injecting pilot fuel. The amount of injected pilot fuel is approximately 1% of the total energy consumption of the engine at 100% Contracted Maximum Continuous Rating (CMCR) engine power. Project-specific values are available in the *GTD*. Gas fuel injection is hydraulically actuated and electronically controlled. Independent micro-injectors and the pilot fuel system inject the pilot fuel. The pilot fuel can be Marine Diesel Oil (MDO) or MGO. The gas mode of the X-DF2.0 engine uses the iCER system, which operates above approximately 26% CMCR engine power.

Diesel mode: Certified Tier II	The main fuel injectors inject the main fuel (HFO, MDO or MGO) in diesel mode. To prevent clogging of the nozzles, the pilot fuel micro-injectors remain in operation at a reduced injection rate. Project-specific values are available in the <i>GTD</i> . The X-DF engine operates in diesel mode with either residual marine fuel (HFO) or with marine distillate fuel (MDO or MGO) which must be in accordance with the ISO 8217:2017 specification. The HFO can have a maximum viscosity of 700cSt. The MDO comprises either DMB or DFB, while the MGO comprises either DMA, DFA, DMZ or DFZ, according to the category definitions in the ISO 8217:2017 specification.
iCER diesel Tier III mode: Certified Tier III	The engine may be selected with the iCER diesel Tier III mode option. While the engine is operating in iCER diesel Tier III mode , 1-13 , the main fuel (MGO only) is used in the same way as in the normal diesel mode operation. However, with the iCER (see section 4.2 , 4-4) active, the engine reaches Tier III compliance without any additional exhaust gas treatment system such as Selective Catalytic Reduction (SCR).
Control system	The WinGD Engine Control System (ECS) manages the key engine functions such as gas admission, exhaust valve drives, engine starting and cylinder lubrication. The engine control system also ensures control of the fuel injection.
Compliance with international codes	The WinGD X82DF-2.0 must comply with the following international codes: <ul style="list-style-type: none">• “International Code for the Construction and Equipment of Ships Carrying Liquefied Gases in Bulk (IGC Code)”• “International Code of Safety for Ship Using Gases or Other Low-flash-point Fuels (IGF Code)”

Special engine features

WinGD is constantly advancing its engine portfolio and developing new technology (see [Table 1-2](#) and [Table 1-3](#), [1-4](#)).

Table 1-2 Principal engine features and technologies

Engine features and technologies	MIM chapter or section
If contracted, iCER diesel Tier III mode is available with this engine (see Figure 1-2 , 1-7).	1.3
In gas operation mode, low-load engine operation is possible.	1.3.1
If contracted, fuel sharing is available with this engine (see Fuel sharing mode , 1-15).	1.3.3
Improved engine performance with reduced environmental footprint. This is made possible through the Intelligent Control by Exhaust Recycling (iCER) system in gas mode. Table 1-3 , 1-4 provides a summary of the iCER system features and components.	4.2
Efficiently cooled piston crown. This is made possible by jet-shaker cooling.	4.4.2
A high-efficiency cylinder lubrication with optimised cylinder lubricating oil consumption is available. This is made possible by the Pulse Lubricating System (PLS).	4.4.5
The engine has a low-pressure gas admission. This is made possible through unique cylinder liners.	4.5.2
Effective gas pressure handling. This is made possible by the Integrated Gas Pressure Regulation (iGPR) unit.	4.5.6
The whole engine can be controlled and operated electronically. This is made possible by the Flex system (see The Flex system , 1-12).	5
Standard data collection and monitoring system. This is known as the WinGD Integrated Digital Expert (WiDE).	5.7
If contracted and if there is a twin-engine installation, then the Synchro-Phasing System (SPS) is available.	6.8.2

Table 1-3 The iCER technology

The iCER system features and components	MIM section
<p>The iCER technology has different operation modes (see Figure 1-2, 1-7):</p> <ul style="list-style-type: none"> • Gas mode • Diesel Tier III mode (optional) <p>The iCER diesel Tier III mode, 1-13 can replace an exhaust gas aftertreatment system such as SCR.</p>	1.3
<p>With the Combustion Stability Mode (CSM), the engine can be operated with gas fuel when the iCER system is not operating. By adding a small part of the liquid fuel, the combustion can be stabilised.</p>	1.3.3
<p>For twin-engine installations, the Exhaust Gas Cooler (EGC) circulation water system and its treatment can be shared between both engines (see Table 4-1, 4-2).</p>	4.1
<p>Simple and reliable iCER technology improves engine performance while reducing Greenhouse Gas (GHG) emissions. An additional economiser (see Figure 4-17, 4-27) can also be installed to recover thermal energy from the hot exhaust gases.</p>	4.2
<p>The EGC circulation water system cools the recirculated exhaust gas to the required temperature (see Figure 4-4, 4-6).</p>	4.2.2
<p>The iCER drainage system is used to discharge the excessive water which is produced from the water condensation out of the exhaust gases. Depending on the iCER operating mode option, the following arrangements are available:</p> <ul style="list-style-type: none"> • Arrangement of the iCER drainage system for installations which run the iCER system exclusively in gas mode, 4-9 • Unified arrangements of the iCER drainage system, valid for all iCER operating mode options, 4-11 	4.2.3
<p>The iCER exhaust gas system is designed to recirculate exhaust gas. The required amount of returned exhaust gas is regulated by a closed loop control system (see Figure 4-14, 4-24).</p>	4.2.5

1.2 Primary engine data

The engine rating field for this specific engine is displayed in [Figure 1-1](#) together with all the WinGD X-DF engines. For detailed engine data see [Table 1-4](#), [1-6](#).

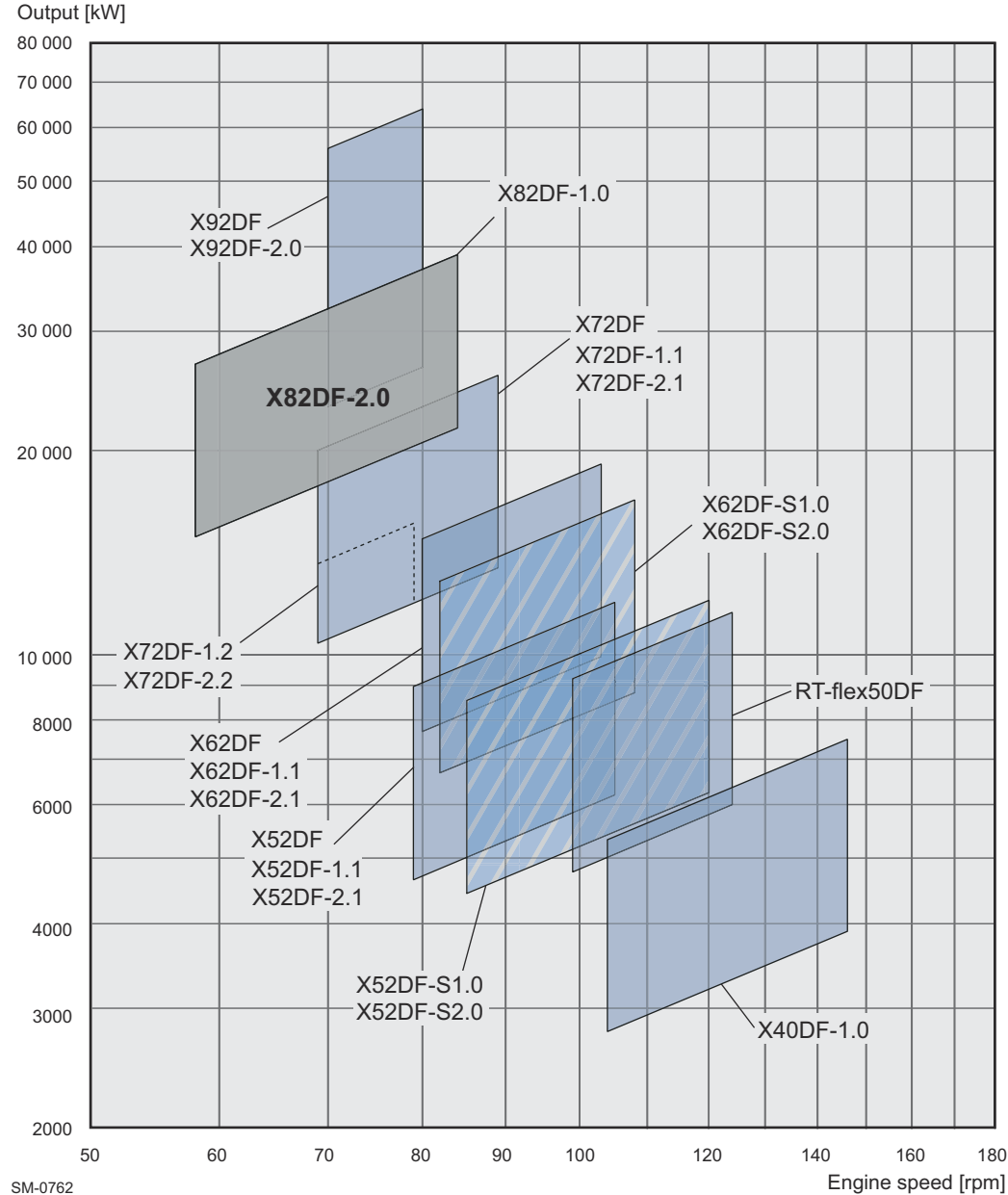

Figure 1-1 Power/speed range of the WinGD X-DF engines

1.2.1 Engine rating field - rating points

The specific values for the four corners of the rating field are called rating points (see [Table 1-4](#)). The values provided in the below table are not binding and may be updated without notice. For prevailing data refer to the *GTD*.

Table 1-4 Rating points

Bore x stroke: 820 x 3,375 [mm]				
No. of cyl.	R1	R2	R3	R4
	Power [kW]			
6	25,920	21,600	17,880	14,940
7	30,240	25,200	20,860	17,430
8	34,560	28,800	23,840	19,920
9	38,880	32,400	26,820	22,410
Speed [rpm]				
All cyl.	84	84	58	58
Mean Effective Pressure (MEP) [bar]				
All cyl.	17.3	14.4	17.3	14.4
Lubricating oil consumption (for fully run-in engines under normal operating conditions)				
System oil	approx. 9 kg/cyl per day			
Cylinder oil	guide feed rate 0.6 g/kWh			

1.3 Fuel operating modes

The engine is designed for continuous service on gas fuel with fuel oil as a back-up fuel. Depending on the selected option, different operating modes are available within specific engine power ranges (see Figure 1-2). The fuel split ranges are shown in Table 1-5, 1-8.

The following list includes the operating modes of the X-DF2.0 engine:

- Gas mode (with the iCER system in operation)
- Combustion stability mode
- Diesel mode
- If contracted, fuel sharing mode
- If contracted, diesel Tier III mode (with the iCER system in operation)

Changeover between the operating modes:

- Transfer (automatically active for changeover to, or between, modes with gas operation)
- Gas trip (immediate action, always available while a mode with gas operation is selected)

NOTE To have either or both the fuel sharing mode and the iCER diesel Tier III mode available, these must be requested and included in the contract.

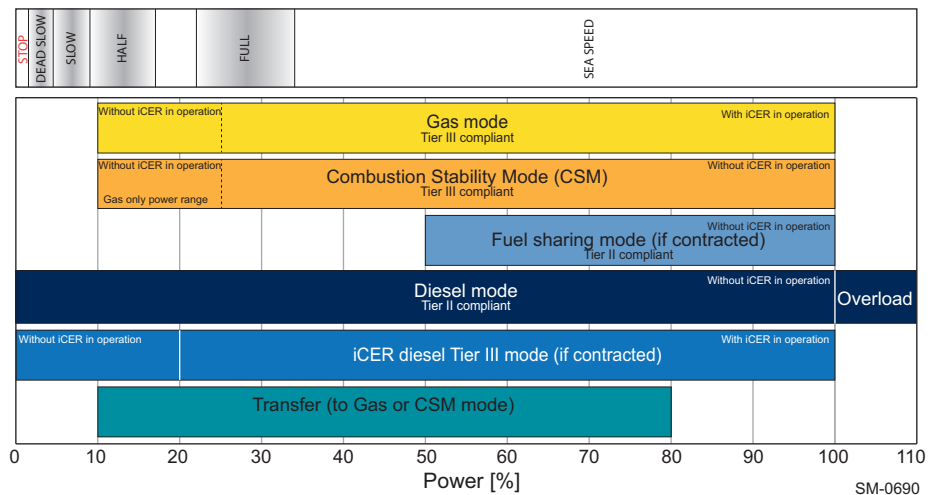

Figure 1-2 Operating modes of the X-DF2.0 engine

Table 1-5 Approximate fuel split (energy-based) for different operating modes over load range

Gas mode operation:	1-2 % MGO/MDO pilot fuel 98-99% gas
Combustion Stability Mode (CSM) operation:	1-2 % MGO/MDO pilot fuel 0-35 % MGO/MDO/HFO (HFO only for above approximately 26 % CMCR engine power) 64-98 % gas fuel
Fuel Sharing Mode (FSM) operation:	1-2 % MGO/MDO pilot fuel 13-49 % MGO/MDO/HFO 50-85 % gas
Diesel mode operation:	1 % MGO/MDO pilot fuel 99 % MGO/MDO/HFO
iCER diesel Tier III mode operation:	1 % MGO/MDO pilot fuel 99 % MGO (ultra low sulphur content - maximum 0.10 % m/m sulphur)

NOTE	It is strongly recommended that transfer and operation in gas mode be initiated above the Barred Speed Range (BSR). As a result this may increase the lower limit value above 10%.
-------------	--

1.3.1 Operation in gas mode

The engine operates in gas mode according to the Otto cycle with a pre-mixed lean fuel gas to air mixture, which is ignited by a small amount of pilot fuel. The amount of injected pilot fuel used is approximately the same across the entire engine power range. This is equivalent to approximately 1% of the total energy consumption of the engine at 100% CMCR engine power (for the energy distribution during gas mode see Figure 1-3).

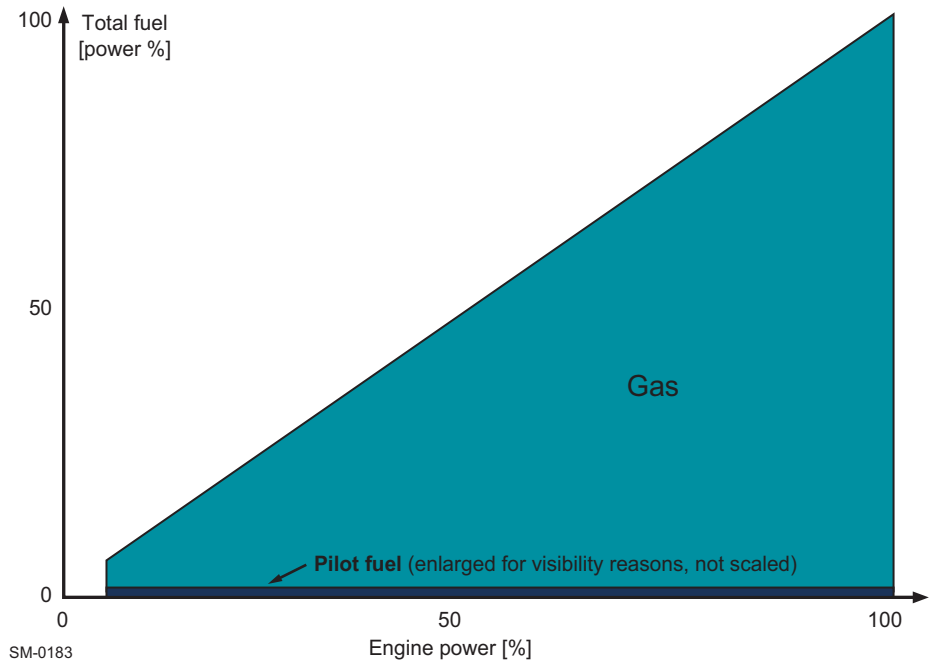

Figure 1-3 Gas mode operation

NOTE	At any time, the gas operation can be stopped immediately by initiating a gas trip.
-------------	---

Shaft power meter requirements

For all WinGD X-DF engines, the ECS requires the installation of a power meter in the shaft line. The measurement accuracy must fulfil the requirements as defined in [Table 1-6](#). The position of the shaft power meter is usually as close as possible to the main engine's flywheel. In the case of a PTO/PTI/PTH installation on the driving end side, this means that the shaft power meter is usually installed between the PTO/PTI/PTH and the main engine's flywheel (see [Figure 4-70](#), [4-125](#)). Alternatively, the mechanical power of the PTO must be calculated and transferred to the ECS through the Propulsion Control System (PCS). This enables the ECS to determine the total mechanical power output of the engine, which is required for the engine operation (see [Figure 5-1](#), [5-1](#)). The same calculation method must be applied to a PTO installation on the free end side.

Table 1-6 Shaft power meter parameters

Abbreviation	Value	Parameter
A	±0.5%	Sensor accuracy
U	≤1.0s	Update rate
D	≤0.5s	Delay
S	≥10 Hz	Sampling rate
ES	4-20mA	Electrical signal

The iCER system

As part of the X-DF2.0 technology, this engine is equipped with the Intelligent Control by Exhaust Recycling (iCER) system. While in gas mode or diesel Tier III mode (if contracted), this allows for the recirculation of part of the exhaust gas back to the engine. This replaces the oxygen in the scavenge air inlet with CO₂, resulting in an enhanced combustion process.

The iCER system offers the following customer benefits:

- Reduced methane slip by up to 50%
- Reduced energy consumption in gas mode
- Improved fuel consumption in diesel mode
- Tier III compliance in diesel mode (if contracted)

[Figure 1-4](#), [1-11](#) provides a schematic of the iCER system.

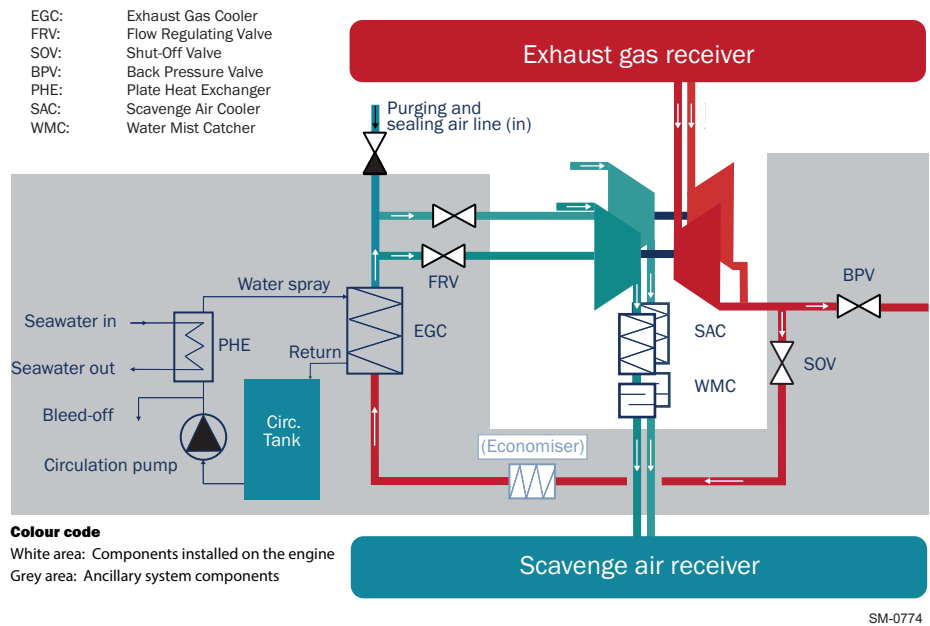

Figure 1-4 The iCER system with the exhaust gas return pipe routed to the turbo-charger connection from below

The introduction of the iCER system, as part of the X-DF2.0 portfolio, increases the competitiveness of the engine with increased fuel efficiency and reduced environmental impact.

For full details of the iCER system, as well as links to associated system information and drawings, see section 4.2 [The iCER technology](#), 4-4.



For further details on the iCER installation, see the [iCER Installation Guideline](#)

1.3.2 Operation in diesel mode

In general, diesel mode is always available. If the gas system fails or the engine output in gas operation mode is insufficient, the diesel mode provides operational flexibility and a fail-safe.

The main fuel injectors inject the main fuel, while the pilot fuel micro-injectors remain in operation at a reduced injection rate to avoid clogging of the nozzles. The main fuel can be changed over from either MDO or MGO to HFO. Before changing back to gas mode, the main fuel must be changed back to MDO or MGO (see section 1.3.4, 1-17).



For engine operation on distillate fuels, see the following Concept Guidance (DG 9723), as provided on the WinGD webpage:

[Concept Guidance Distillate Fuels](#)

The Flex system

The engine is equipped with WinGD's common-rail injection system which enables flexible fuel injection.

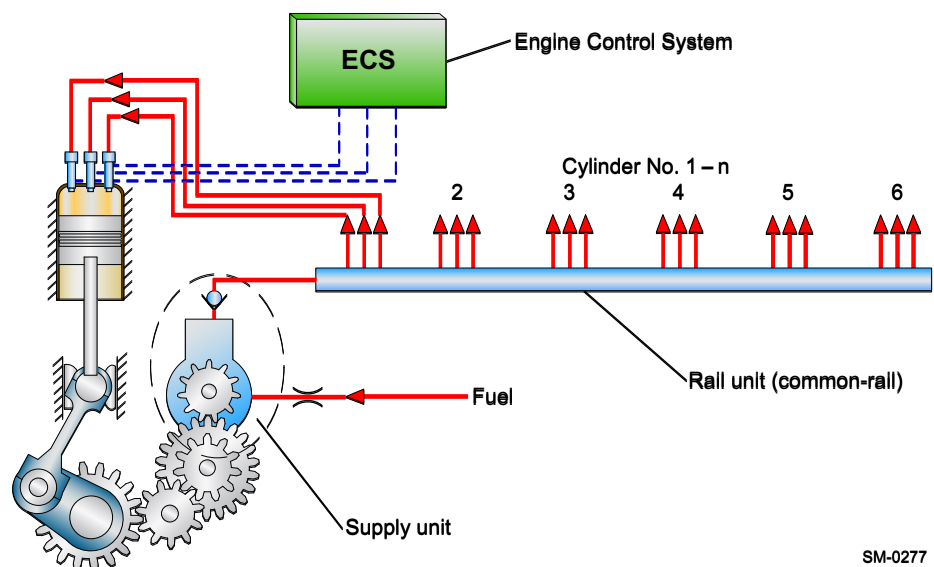

Figure 1-5 The Flex system parts

Major benefits

- Adapted for different operating modes
- Adapted for different fuels
- Optimised part load operation
- Optimised fuel consumption
- Precise speed regulation, especially at very low speed operation
- Smokeless operation across the entire engine power range
- Benefits in terms of operating costs, maintenance requirements and compliance with emissions regulations

iCER diesel Tier III mode

The iCER diesel Tier III mode is available from 0 to 100% engine power and the iCER is active from approximately 20 to 100% engine power. This engine operation mode uses MGO fuel (with maximum 0.10% m/m sulphur), and reaches Tier III compliance.

The iCER system (see section 4.2, [4-4](#)) requires the activation of the EGC circulation water treatment system. For further information, please see section 4.2.3 [The iCER drainage system, 4-8](#).

1.3.3 Operation in a mixed fuel mode

A mixed fuel mode runs on both gas and liquid fuel at the same time. The power available and the diesel fuel ratio is dependent on the selected mixed fuel mode.

Combustion stability mode

The Combustion Stability Mode (CSM) technology is specific to the engines of the X-DF2.0 portfolio and can be selected as an operating mode across the same engine power range as gas mode (see [Figure 1-2](#), [1-7](#)). When the CSM is selected, the engine will run mainly on gas fuel, however without the iCER.

NOTE While the CSM is active, the engine is Tier III compliant, as long as the sulphur content of the liquid fuel is equal to or less than 0.10% sulphur m/m.

The CSM can be active above 10% CMCR power. From 10% and up to approximately 26% CMCR power, only gas fuel is applied. Starting from approximately 26% CMCR power, a part of the gas fuel is replaced with liquid fuel to ensure stable combustion. The maximum gas-only power indicated at 26% CMCR power can vary depending on the engine rating.

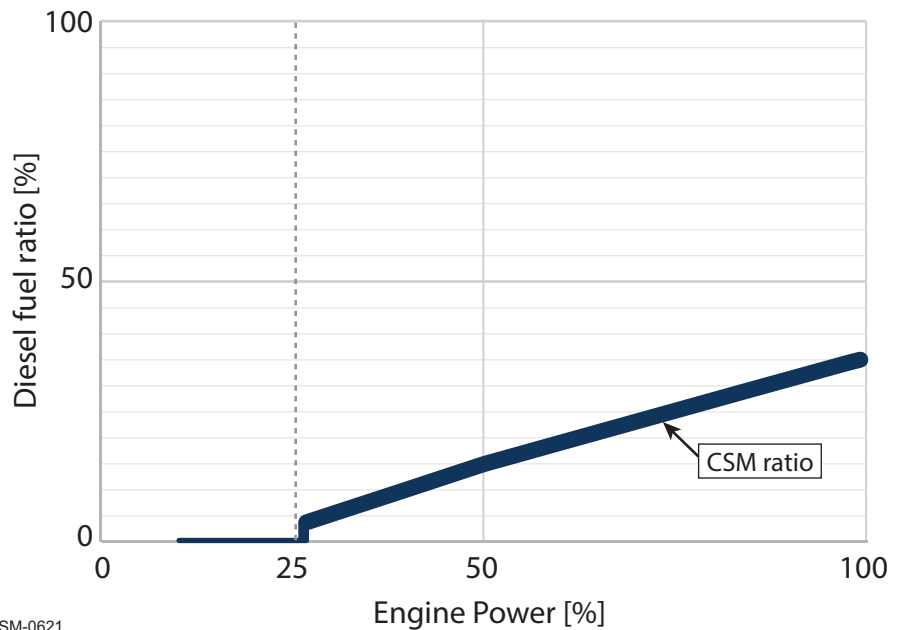

SM-0621
Figure 1-6 Diesel fuel ratio during active CSM

The CSM, like the FSM, injects liquid fuel by the main injectors, in addition to the gas fuel. However, unlike FSM, the diesel fuel ratio is set by the CSM as shown in [Figure 1-6](#).

The amount (or ratio) of the diesel injected is fixed as a function of the engine power and is controlled by the ECS. The expected amount is shown in [Figure 1-6](#), however the final vector can vary depending on the engine rating.

The CSM comes as standard technology with engines that have iCER.

Fuel sharing mode

NOTE Fuel sharing mode must be contracted, it is optional at additional cost.

The fuel sharing mode is initiated only by the operator and can be used for reaching the balance between an LNG carrier’s boil-off and the desired ship speed. This can be done by adjusting the ratio of the liquid to gas fuel.

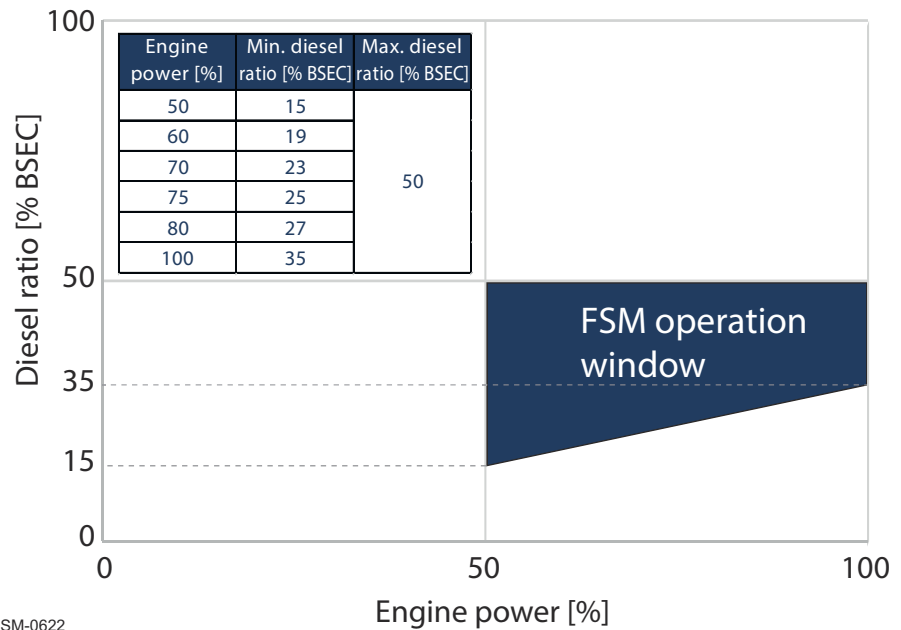

SM-0622

Figure 1-7 Fuel sharing mode — available operating window

The fuel sharing mode is available in a defined working window (see [Figure 1-7](#)). Like CSM activation (see the subsection [Combustion stability mode](#), [1-14](#)), the minimum amount of liquid fuel is dependent on the engine power and is limited by the ECS. During fuel sharing mode the engine is Tier II compliant.

1.3.4 Changeover between operating modes

The changeover between operating modes is the process of the engine changing between different fuel operating modes (see section 1.3, 1-7).

Depending on the type of changeover between operating modes, the time required will vary. Generally, a changeover of operation mode from gas to liquid fuel is executed immediately. However, the introduction of gas will take a few minutes depending on the operating modes.

Diesel mode operation:	An overload of 110% is permitted in emergency conditions (SOLAS Regulations II-1/3.6)
Gas, CSM, FSM, and diesel Tier III mode operation:	No overload is available, as the maximum continuous output is 100% of rated power

All changeovers are restricted by the engine power availability of each operating mode and the transfer power range (see Figure 1-2, 1-7).

Transfers and gas trips

The changeover between operating modes can be categorised in two ways. If the changeover introduces or continues to use gas fuel, it is called a transfer. If the changeover between operating modes stops the use of gas fuel, therefore defaulting to diesel mode, then the changeover is called a gas trip (or just a trip). Often a gas trip is associated with automatic initiation as part of a system safety procedure, but it can also be intentionally initiated by the operator. In comparison to a gas trip, the transfer between operating modes can only happen from operator initiation.

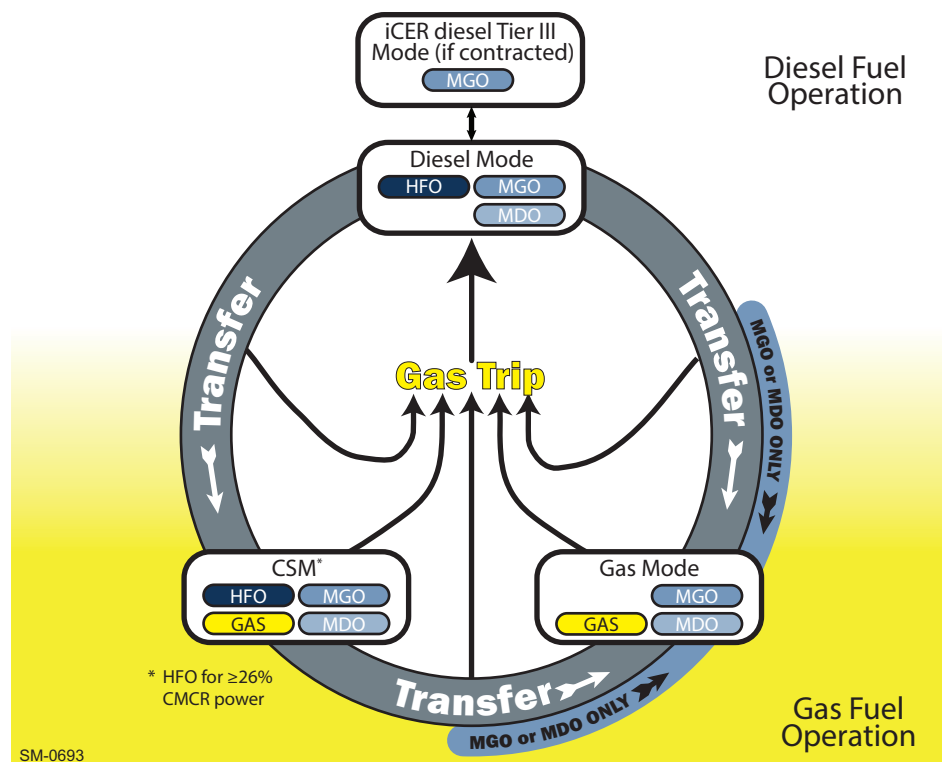

Figure 1-9 If FSM is not contracted, the fuel transfers and gas trips

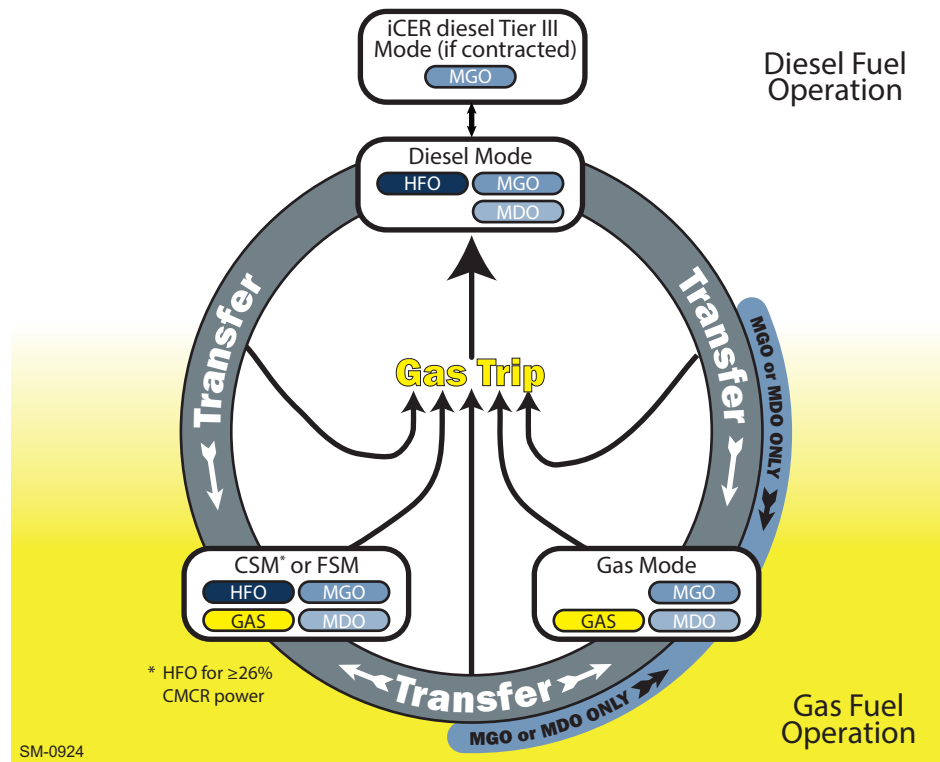

Figure 1-10 If FSM is contracted, the fuel transfers and gas trips

Gas trip

A gas trip will always stop the gas fuel operation, and results in diesel mode operation. The gas trip is completed within half a revolution of the engine and can occur at any engine power and any operating mode where gas fuel is in use. This includes any point of transfer between operating modes.

While the engine runs in gas mode, the liquid fuel backup system is always on standby with MGO or MDO. This is different to fuel sharing mode which is backed up by the selected fuel type (see Table 1-5, 1-8).

Although the operator can initiate a gas trip to diesel mode, if the engine control system initiates an automatic gas trip it is a result of either an unacceptable operating condition, a detected failure or a command received from an external system (e.g. the engine safety system). If an automatically initiated gas trip occurs, then the cause must be investigated. Transferring to an operation mode with gas is therefore prohibited and disabled until the problem is resolved and the alarm is reset.



Failures causing a gas trip are described in detail by the document that follows:
2-Stroke Dual-Fuel Safety Concept

Transfer introducing gas fuel

The transfer from diesel mode to either gas mode or fuel sharing mode introduces gas fuel. Both the GVU and the iGPR must complete a system safety test before this gradual changeover can take place.

Gas mode The transfer to gas mode is prohibited (and therefore disabled) when the engine is running on HFO. Before changing to gas mode, the engine must operate in diesel mode (Tier II) with MGO or MDO until the fuel system is fully flushed of HFO. This prevents clogging by HFO during standby in gas mode. For transfer to gas mode, the iCER system must be ready for operation, and will only operate above approximately 26% CMCR engine power.

CSM If the engine is running in diesel mode (Tier II) above approximately 10% CMCR engine power, the transfer to CSM is possible. MDO and MGO can be used as liquid fuel. HFO can also be used above approximately 26% CMCR engine power. If FSM is contracted, a direct transfer from gas mode to CSM is available. When the engine power is reduced below the CSM's operating range, an alarm message is released. If the engine power is not increased within the required time period, a gas trip is initiated.

FSM FSM is only available if contracted. If the engine is running above approximately 50% CMCR engine power, transfer from either diesel mode (Tier II) or gas mode to FSM is possible. HFO, MDO and MGO can be used as liquid fuel. When the engine power is reduced below the FSM's operating range, an alarm message is released. If the engine power is not increased within the required time period, a gas trip is initiated.

NOTE

Fuel sharing mode must be contracted, it is optional at additional cost.

Changeover between liquid fuels

Similar to WinGD diesel engines, changing the fuel input from HFO to either MGO or MDO and vice versa can be done at any time (assuming HFO is permitted in the operating mode) without interruption of engine operation. The fuel oil changeovers are managed by external systems.

Changeover to iCER diesel Tier III mode

Before changing to iCER diesel Tier III mode, the engine must be in diesel mode and fully flushed with MGO (with maximum 0.10% m/m sulphur). The iCER system must be ready for operation, and will only operate above approximately 20% CMCR engine power.

2 Engine Power and Speed

Selecting a suitable main engine to meet the power demands of a given project involves proper tuning with respect to load range and influence of operating conditions which are likely to prevail throughout the entire life of the ship. This chapter explains the main principles in selecting a WinGD 2-stroke marine diesel and gas engine.

2.1 Introduction to power and speed

It is critical that a ship's propulsion system correctly matches the main engine characteristics to ensure reliable operation under a variety of conditions including design and off-design conditions. The sections below outline the specifics to aid in this process.

2.2 Engine rating field

The rating field shown in Figure 2-1 is the area of selectable engine design power and engine design speed. In this area, the Contracted Maximum Continuous Rating (CMCR) of an engine can be positioned individually to give the desired combination of propulsive power and rotational speed. Engines within this layout field are tuned for maximum firing pressure and best efficiency at the selected rating.

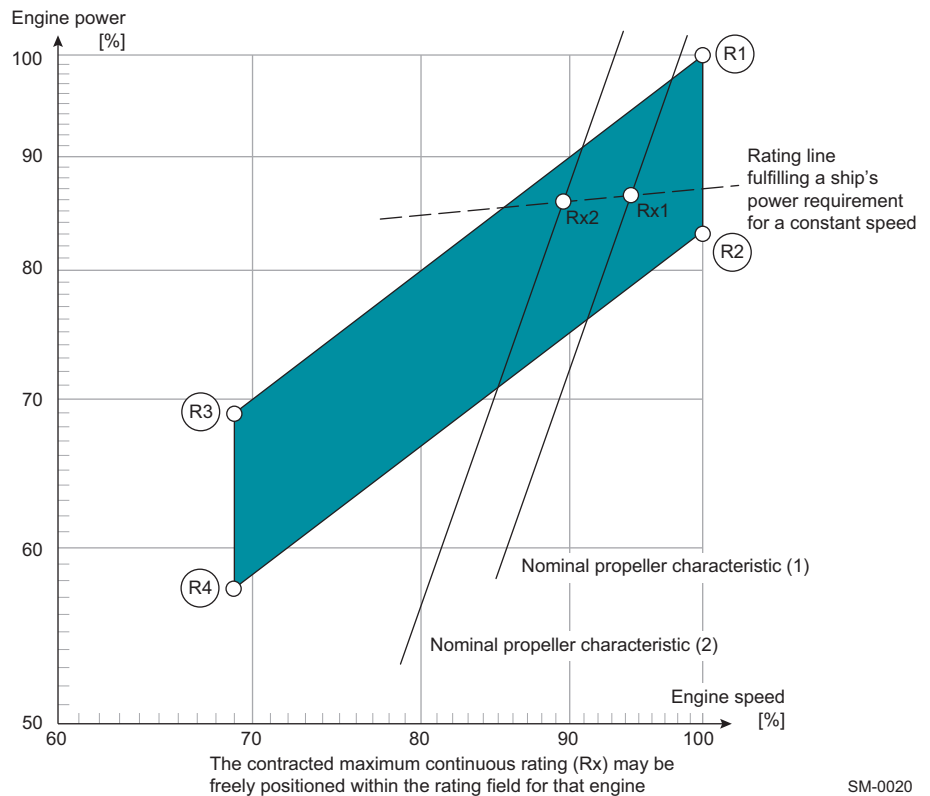

Figure 2-1 Rating field for the X82DF-2.0

The rating field serves to determine the specific fuel and fuel gas consumption, exhaust gas flow and temperature, fuel injection parameters, turbocharger and scavenge air cooler specifications at the selected rating.

Percentage values

The engine speed is given on the horizontal axis and the engine power on the vertical axis of the rating field. Both are expressed as a percentage [%] of the respective engine’s nominal R1 parameters. Percentage values are used so that the same diagram can be applied to various engine arrangements.

Rating points

The rating points (R1, R2, R3, R4) for WinGD engines are the corner points of the engine rating field (see Figure 2-1, 2-1). The rating field is limited by two constant Mean Effective Pressure (MEP) lines R1—R3 and R2—R4 and by two constant engine speed lines R1—R2 and R3—R4.

The point R1 represents the nominal Maximum Continuous Rating (MCR). It is the maximum power/speed combination which is available for a particular engine.

Any rating point (Rx) can be selected within the entire rating field to meet the requirements of each specific project. Such rating points require specific engine adaptations.

2.3 Influence of propeller diameter and revolutions

Influence of propeller revolutions on the power requirement

At constant ship speed and for a given propeller type, a lower propeller speed combined with a larger propeller diameter increases the total propulsive efficiency. Less power is required to propel the vessel at a given speed.

The relative change of required power as a function of the propeller revolutions can be approximated by the following relation:

$$\frac{PX_2}{PX_1} = \left(\frac{n_2}{n_1}\right)^\alpha$$

Formula 2-1

where:

- PX_j = propulsive power for propeller revolution n_j
- n_j = propeller speed corresponding with propulsive power PX_j
- α = 0.15 for tankers and general cargo ships up to 10,000dwt, or
 = 0.20 for tankers and bulk carriers from 10,000 to 30,000dwt, or
 = 0.25 for tankers and bulk carriers larger than 30,000dwt, or
 = 0.17 for reefers and container ships up to 3,000 TEU, or
 = 0.22 for container ships larger than 3,000 TEU

This relation is used in the engine selection process to compare different engine alternatives and to select an optimum propeller speed within the selected engine rating field. Usually, the number of revolutions depends on the maximum permissible propeller diameter.

Maximum propeller diameter

The maximum propeller diameter is often determined by operational requirements, such as:

- Design draught and ballast draught limitations
- Class recommendations concerning propeller/hull clearance (pressure impulse induced on the hull by the propeller)

The selection of a main engine in combination with the optimum propeller (efficiency) is an iterative process where also commercial considerations (engine and propeller prices) play an important role.

According to the above approximation, when a required power/speed combination is known (for example, point Rx1 in Figure 2-1, 2-1), a contracted maximum continuous rating line can be drawn which fulfils the ship's power requirement for a constant speed. The slope of this line depends on the ship's characteristics (see coefficient α in Formula 2-1, 2-2). Any other point on this line represents a new power/speed combination, for example Rx2, and requires a specific propeller adaptation.

2.4 Power range

Propeller curves and operational points

To establish the proper propeller curves, it is necessary to know the ship's speed to power response.

Determining power/propeller speed relationships

Normally, the curves can be determined by using full-scale trial results from similar ships, algorithms developed by maritime research institutes, or model tank results. With this information and by applying the propeller series, the power/speed relationships can be established and characteristics developed.

The relation between absorbed power and propeller speed for a Fixed Pitch Propeller (FPP) can be approximated by the following cubic relation:

$$\frac{P}{P_{CMCR}} = \left(\frac{n}{n_{CMCR}} \right)^3$$

Formula 2-2

where:

- P = propeller power
- n = propeller speed

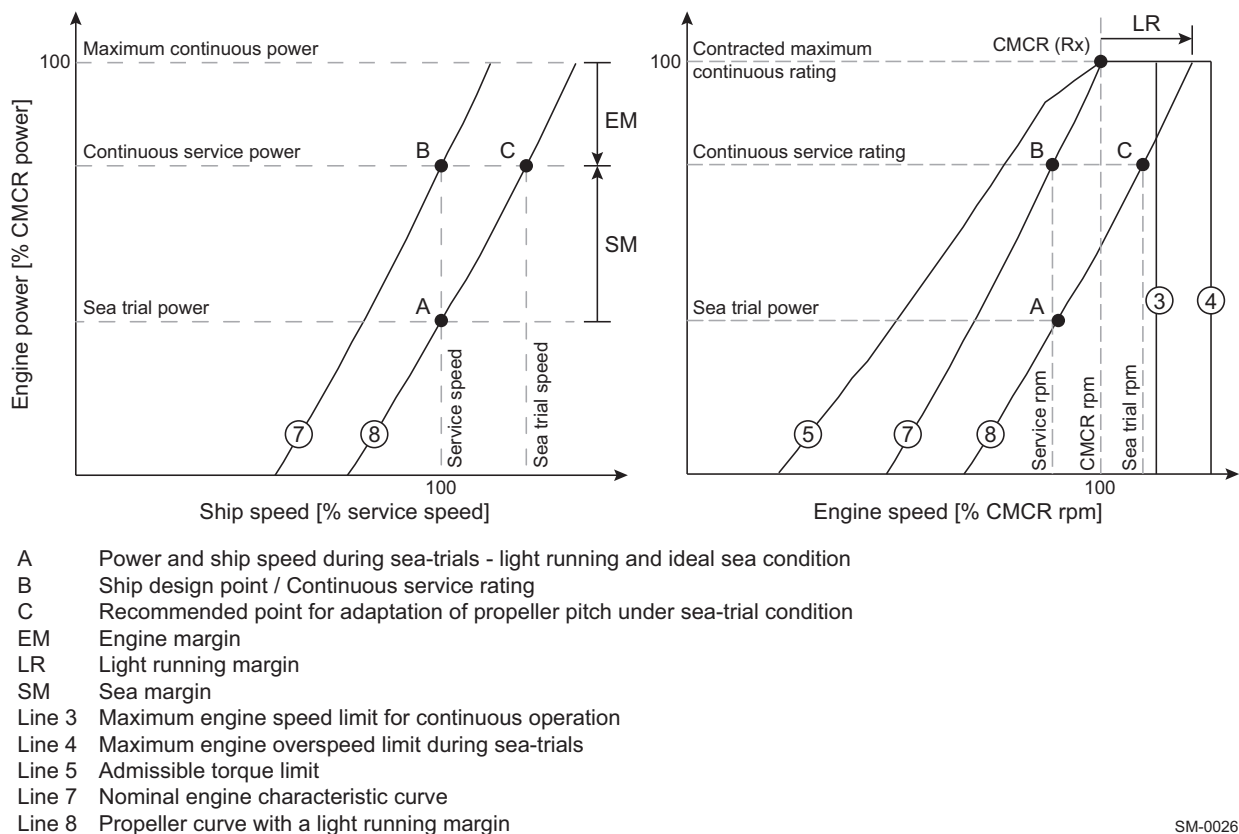

Figure 2-2 Propeller curves and operational points

Figure 2-2 outlines the various engine limits, propeller curves and margins required for engine optimisation. By incorporating the margins listed below, the various operational points and subsequently the CMCR point can be determined (see section 2.5, 2-6 for detailed descriptions of the various line limits).

Sea trial power

The sea trial power must be specified. Figure 2-2 shows the sea trial power to be the power required for reaching service speed (point A) on the propeller curve with a light running margin (Line 8).

Sea margin

The Sea Margin (SM) is defined as the increase in power to maintain a given ship’s speed achieved in calm weather (point A in Figure 2-2) under average service condition (point B). This margin can vary depending on the owner’s and charterer’s expectations, routes, season and schedules of the ship.

The location of reference point A and the magnitude of the sea margin are part of the new building contract and are determined between the shipbuilder and the owner. Typically, the sea margin is specified in the range of 10 to 25% of the sea trial power.

Light running margin

The Light Running (LR) margin (see [Figure 2-2](#), [Figure 2-4](#)) is added to compensate for the expected change in speed to relative power, caused by the fouling and the deterioration of the vessel over time. For a given engine power output, the light running propeller (Line 8) operates at a certain percentage of higher propeller speed compared to the nominal engine characteristic (Line 7). The light running margin is agreed upon between the shipyard and the ship owner. The margin depends on the hull and the propeller cleaning interval, as well as the operation route which will affect the rate of deterioration (e.g. speed, location, shallow water, etc.)

Typically, the light running margin is specified in the range of 4 to 7%. However, additional power/engine speed allowance must be provided for the Power Take-Off (PTO) installations (see section [2.6](#), [Figure 2-10](#)).

NOTE

The shipbuilder has the responsibility to determine a light running margin. This light running margin must be sufficiently small so that the power range limits on the right side of the nominal propeller characteristic (Line 7) are reached under any service condition (see [Figure 2-3](#), [Figure 2-6](#)).

Continuous service rating

The Continuous Service Rating (CSR) is also known as the Nominal Operation Rating (NOR) or the Nominal Continuous Rating (NCR). Point A represents the power and propeller speed of a ship operating at contractual service speed in calm seas with a new clean hull and propeller. On the other hand, the same ship at the same speed, under service conditions with aged hull and under average weather conditions, requires a power/speed combination according to point B. In that case, point B is the CSR point.

Engine margin

The Engine Margin (EM) is the relative power (in percentage) which remains at CSR. Most owners specify the contractual ship's loaded service speed at 85 to 90% power of the contracted maximum continuous rating. Different selections are possible. This remaining power, the EM (e.g. 10 to 15%), can then be used to catch up with delays in schedule.

This margin is deducted from the CMCR. Therefore, the 100% power line is found by dividing the power at point B by the selected percentage (e.g. 85 to 90%) of CSR power. The graphic approach to find the level of CMCR is illustrated in [Figure 2-2](#), [Figure 2-4](#).

Contracted maximum continuous rating

The Contracted Maximum Continuous Rating (CMCR) is also known as the Rx or the Specified Maximum Continuous Rating (SMCR). The CMCR is the point obtained by applying the margins (SM and EM) to the propeller curves. The calculated CMCR point can be selected freely within the entire engine rating field.

2.5 Power range limits

Once an engine is optimised at CMCR (Rx), the working range of the engine is limited by the following border lines (see Figure 2-3).

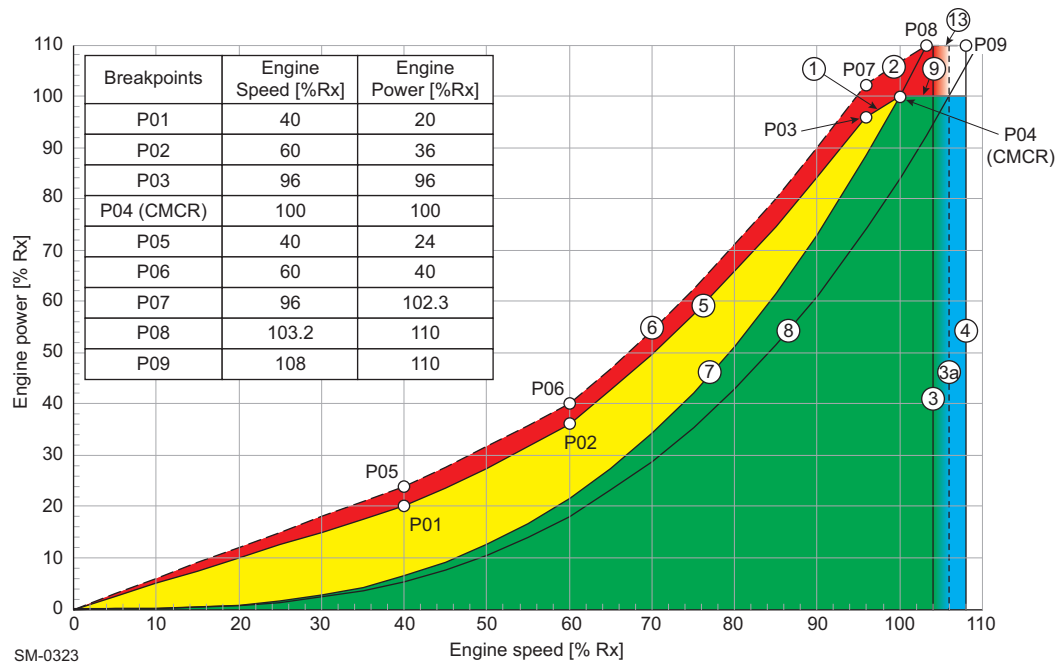

Figure 2-3 Power range limits

**Line 1
100% Torque Limit**

Constant MEP or torque line through CMCR from 100% (speed and power) down to 96% (speed and power).

**Line 2
Overload Limit**

Available in diesel mode for testbed operation and emergency operation according to SOLAS Regulation II-1/3.6. It is a constant MEP line, connecting point P07 (102.3% power and 96% speed) to point P08 (110% power and 103.2% speed). Point P08 is the point of intersection between Line 7 and 110% power. Overload is not permitted in gas mode. If overload is attempted in gas mode, then the engine’s safety system will automatically initiate a gas trip to diesel mode at 102% power.

**Line 3
Speed Limit**

Maximum speed limit for continuous engine running is set to 104% of CMCR speed. However, in diesel mode this limit can be extended to 106% (Line 3a) if Rx speed is reduced ($n_{CMCR} \leq 0.98n_{MCR}$), provided that the specified torsional vibration limits are not exceeded.

**Line 4
Overspeed Limit**

The overspeed range, from Line 3 at 104% (or Line 3a at 106% for selected engines in diesel mode) can extend to an upper speed limit of 108%. If needed for demonstration of 100% CMCR power operation during sea trials, operating in this overspeed range is only permissible in the presence of an authorised engine builder representative. However, the specified torsional vibration limits must not be exceeded.

**Line 5
Engine Operation
Power Limit** Admissible power limit for engine operation. The line is separated by the break-points listed in [Figure 2-3](#), [2-6](#).

**Line 6
Transient Operation
Power Limit** Maximum power limit for transient operation, available only in diesel mode. The line is separated by the breakpoints listed in [Figure 2-3](#), [2-6](#).

**Line 7
Nominal Engine
Characteristic** Nominal engine characteristic curve that passes through the CMCR point is defined by the propeller law:

$$\frac{P}{P_{CMCR}} = \left(\frac{n}{n_{CMCR}} \right)^3$$

Formula 2-3

**Line 8
Light Running
Propeller Curve** Propeller curve with a light running margin (typically between 4% and 7%). The curve is defined by the propeller law with a constant, governed by the selected light running margin ([Formula 2-4](#)).

$$\frac{P_{LR}}{P_{CMCR}} = C \cdot \left(\frac{n}{n_{CMCR}} \right)^3 \quad C = \left(\frac{1}{1 + LR} \right)^3$$

Formula 2-4

where:

- P_{LR} = propeller power at selected light running margin [kW]
- P_{CMCR} = CMCR engine power [kW]
- n = selected engine speed [rpm]
- n_{CMCR} = CMCR engine speed [rpm]
- C = constant
- LR = light running margin [%]

**Line 9
CMCR Power** Maximum power for continuous operation.

**Line 13
110% CMCR Power** Constant power overload limit, available for testbed operation and emergency operation according to SOLAS Regulation II-1/3.6.

Engine Operation Power Range

Line 5, Line 1 and Line 9 form the curve for the engine’s operation power range limit, as defined by [Formula 2-5](#). Each component is governed by different coefficients (see [Table 2-1](#)).

Table 2-1 Line 5 coefficients

Line no.	Range (n/n_{CMCR})	C2	C1	C0
Line 5	0.00 - 0.40	0.000	0.500	0.000
	0.40 - 0.60	0.500	0.300	0.000
	0.60 - 0.96	1.111	-0.067	0.000
Line 1	0.96 - 1.00	0.000	1.000	0.000
Line 9	1.00 - 1.08	0.000	0.000	1.000

$$\frac{P}{P_{CMCR}} = C2 \left(\frac{n}{n_{CMCR}} \right)^2 + C1 \left(\frac{n}{n_{CMCR}} \right) + C0$$

Formula 2-5

where:

- P = selected engine power [kW]
- P_{CMCR} = CMCR engine power [kW]
- n = selected engine speed [rpm]
- n_{CMCR} = CMCR engine speed [rpm]
- $C2/C1/C0$.. = coefficients / constants

The area formed by Lines 1, 3, 5 and 9 is the range within which the engine should be operated.

The area limited by Line 7, Line 9 and Line 3 is recommended for continuous operation.

The area between Line 7 and Line 5 is reserved for acceleration, shallow water and normal operational flexibility. If a PTO is installed, then the operating characteristics of the engine will differ (see section 2.6, [Fig 2-10](#) for further details regarding PTO characteristics).

Overload Power Range

Line 6, Line 2 and Line 13 form the curve for the engine's overload power limit, as defined by [Formula 2-5](#), [Figure 2-8](#). Each component is governed by different coefficients (see [Table 2-2](#)).

Table 2-2 Line 6 coefficients

Line no.	Range (n/n_{CMCR})	C2	C1	C0
Line 6	0.00 - 0.40	0.000	0.600	0.000
	0.40 - 0.60	0.330	0.468	0.000
	0.60 - 0.96	1.110	0.000	0.000
Line 2	0.96 - 1.032	0.000	1.066	0.000
Line 13	1.032 - 1.08	0.000	0.000	1.100

The area above Lines 1 and 9 is the overload range. It is only permissible to operate engines in this range for a maximum duration of one hour during sea trials and in the presence of an authorised engine builder representative.

The area between Lines 1, 5 and 6 ([Figure 2-3](#), [Figure 2-6](#)), called 'service range with operational time limit', is only applicable to transient conditions in diesel mode (i.e. passing through a barred speed range, sea trial or emergency fast acceleration). The engine can only be operated in this area for limited periods of time, in particular one hour per 24 hours.

2.6 Power range limits with a power take-off installation for a FPP

A main engine-driven generator is named as a Power Take-Off (PTO), as its driving power is provided by the main engine. The addition of a PTO installation alters the working range and operating characteristics of the engine. Two methods of incorporating the PTO are outlined in the following sections. WinGD recommends to follow Method 1.

PTO considerations

- The PTO is used for generating the navigation electric power
- The PTO is connected with a frequency converter system
- The PTO is not engaged in heavy sea conditions
- Mechanical power absorption of the PTO must be considered

PTO incorporation of Method 1

CMCR - Method 1

This first method considers the PTO as an addition to the previously defined propeller power requirements, therefore increasing the CMCR of the engine.

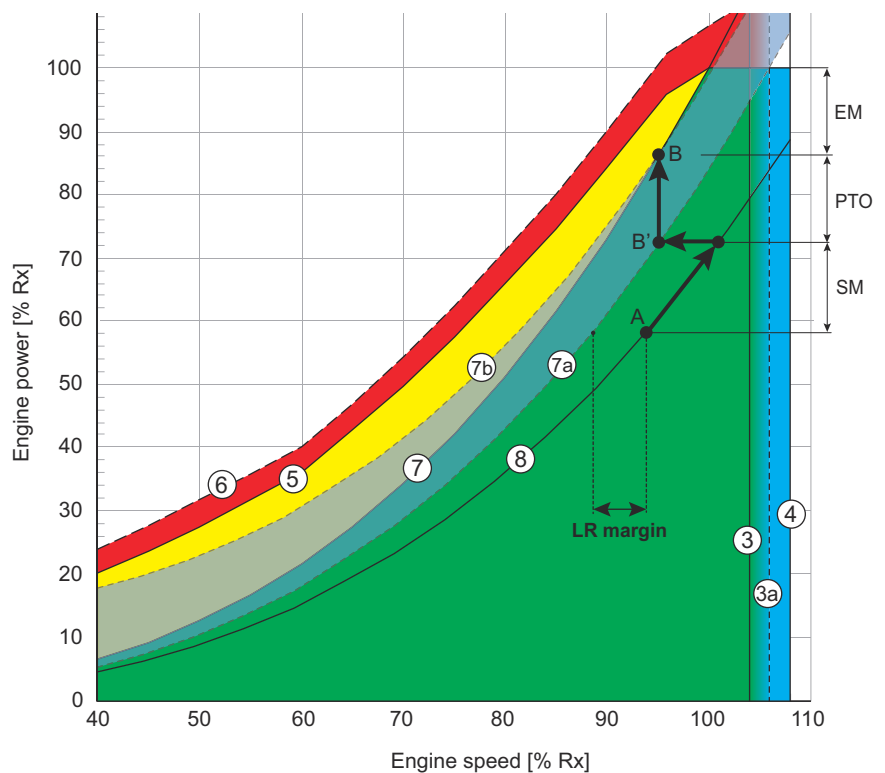

(Line 7) = Nominal engine characteristic
 (Line 7a) = Nominal propeller characteristic without PTO
 (Line 7b) = Nominal propeller characteristic with PTO
 Point A = Light running in ideal sea conditions (sea trial)
 Point B = CSR
 Point B' = Continuous service without PTO power

SM-0029

Figure 2-4 Power range diagram of an engine with a PTO

Line 7a in Figure 2-4 shows the power required for the propeller, where Line 7b shows the power needed for the propeller combined with a constant power requirement from the PTO.

With the addition of a constant nominal generator power across the engine power range, the engine curve is changed, so no longer directly related to a propeller characteristic. In Figure 2-4, 2-10, the PTO is assumed to absorb 15% of nominal engine power. The CSR point includes the PTO power demand, this is shown in the same figure between points B' and B. The CMCR point is selected from this propeller curve. This curve defines the nominal engine characteristic.

Method 1 allows for practical and flexible PTO operation, as limitations will only occur in the engine's lower speed range. At this lower speed range, the PTO is limited by a minimum speed requirement (as defined by the PTO device supplier) and by the PTO layout limit Line 10 (only relevant if the PTO operation is using a significant percentage of engine power).

**Line 10
PTO Layout Limit**

The PTO layout limit (Line 10 in Figure 2-5) defines the power limit for the resulting combination of the propeller and PTO. Defining Line 10 as the PTO layout limit provides a margin for normal power load fluctuation and acceleration.

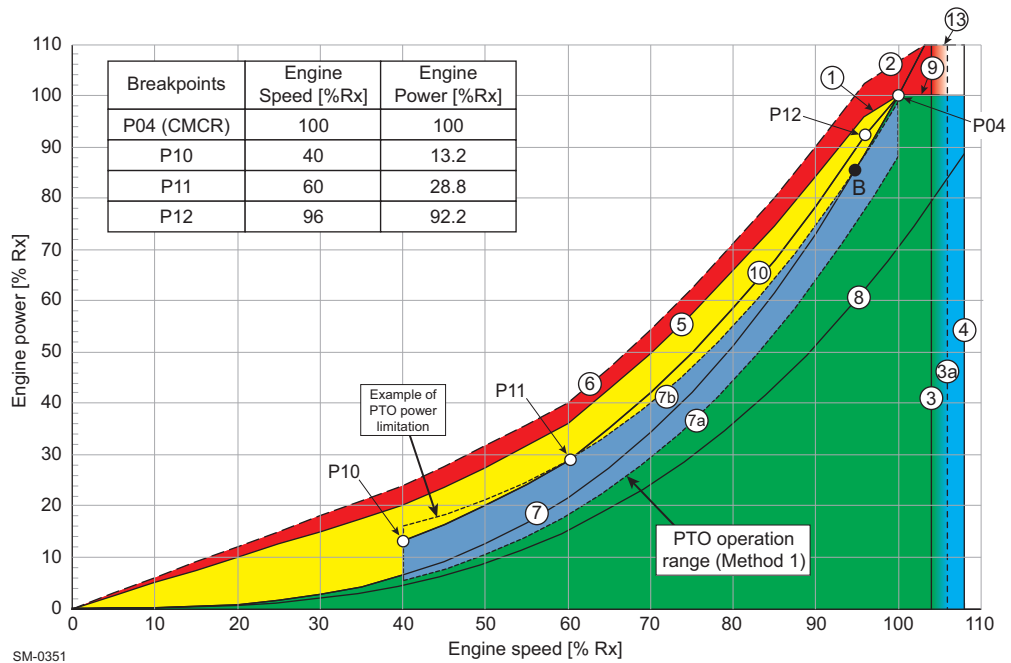

Figure 2-5 Power range limits for PTO operation — Method 1

The breakpoints of Line 10 are listed in Figure 2-5. Line 10 is a curve defined by Formula 2-5, 2-8. The different components have a different coefficient, forming the entire curve (see Table 2-3 for the individual coefficients).

Table 2-3 Line 10 coefficients

Line no.	Range (n/n_{CMCR})	C2	C1	C0
Line 10	0.40 - 0.60	0.750	0.030	0.000
	0.60 - 0.96	1.336	-0.321	0.000
	0.96 - 1.00	0.000	1.941	-0.941

PTO incorporation of Method 2

CMCR - Method 2

With this second method, the engine’s CMCR is determined by the propeller power only. The PTO uses the available engine power which is not absorbed by the propeller.

As shown in Figure 2-6, the available power for PTO application is between Line 8 and Line 10. Therefore, the available PTO power depends on the available light running margin at the current time.

When considering this method, a light running margin of approximately 8% is recommended.

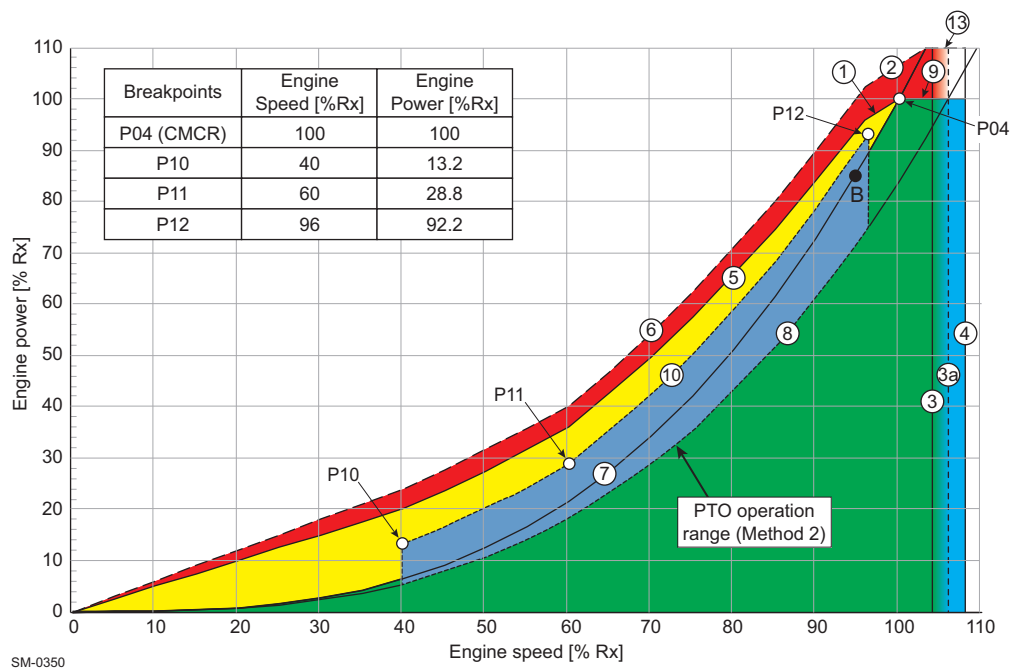

Figure 2-6 Power range limits for PTO operation — Method 2

The PTO power must be controlled by the ship power management system, which ensures that the engine operating point will not exceed Line 10.

Further information

The following disadvantages must be observed for Method 2:

- With the reduction of the light running margin (as a consequence of the ageing hull and propeller) the available PTO power will be reduced and must be limited by the ship power management system.
- The PTO is typically engaged in approximately 40 to 96.5% of engine speed. The final lower limit must be defined with the supplier of the generator. The final upper limit must be set to the project-related CSR engine speed.

If the requested PTO power is higher than the limits defined by Method 2, an increase in CMCR power is necessary.

2.7 Prohibited operation area

Within the higher speed range of the engine there is a prohibited operation area defined by a minimum engine power requirement. If the propeller is disconnected from the engine, the engine would be capable of entering the prohibited operation area, which is strictly forbidden (see section 4.13.6, 4-131 for PTO testing).

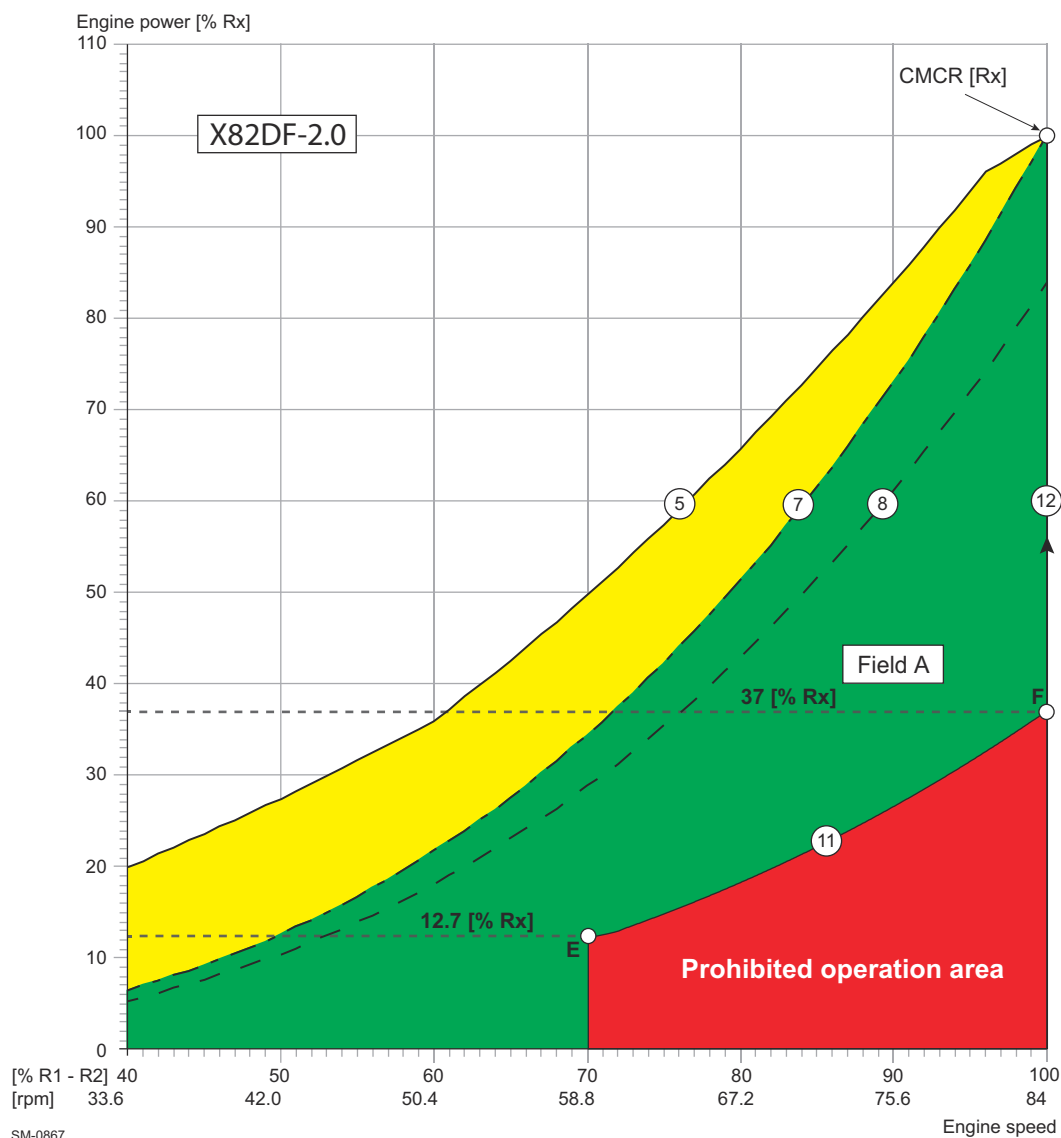

Figure 2-7 The prohibited operation area (CMCr speed = R1—R2)

NOTE It is strictly forbidden for the engine to enter the prohibited operation area.

As seen in [Figure 2-7](#), [Fig 2-13](#), the prohibited operation area of an engine is defined by an engine tuned to an R1—R2 speed. At this speed rating the restriction exists between 70% and 100% speed, with a required minimum engine power at these points of 5.8% and 17%, respectively. These values are governed by the [Formula 2-6](#) for Line 11.

If the CMCR speed rating of the engine is less than the R1—R2 speed, the required minimum power at this point is also calculated by the Line 11 equation.

Line 11 The lowest operational power limit, between 70% of R1—R2 speed and 100% CMCR speed, is defined by the following equation:

$$\text{Line11} = 0.17 \times \left(\frac{n}{n_{R1-R2}} \right)^3$$

Formula 2-6

As calculated by this equation and shown in [Figure 2-7](#), [Fig 2-13](#), at 70% of R1—R2 speed the minimum engine power equals approximately 5.8% of the CMCR power (point E). The minimum power requirement at 100% CMCR speed (point F) must be calculated depending on the engine rating. Examples of this calculation are shown further on.

Line 12 While operating at 100% CMCR speed, the allowed engine power can range between the minimum required power (point F) and 100% CMCR power.

Field A The available design range of the engine is defined by Line 7, Line 11 and Line 12.

NOTE

For test purposes, the engine may run within the prohibited operation area for a maximum of 30 minutes during testing and sea trials. This operation is only permissible at low load and in the presence of authorised representatives of the engine builder. Further requests must be agreed upon by WinGD.

NOTE

The operational design range must respect the Barred Speed Range (BSR) limits from torsional vibration.

Prohibited operation area for different speed rated engines

As the prohibited operation area of the engine is between 70% and 100% of the R1—R2 speed, the prohibited area is smaller when the speed rating of the engine is lowered.

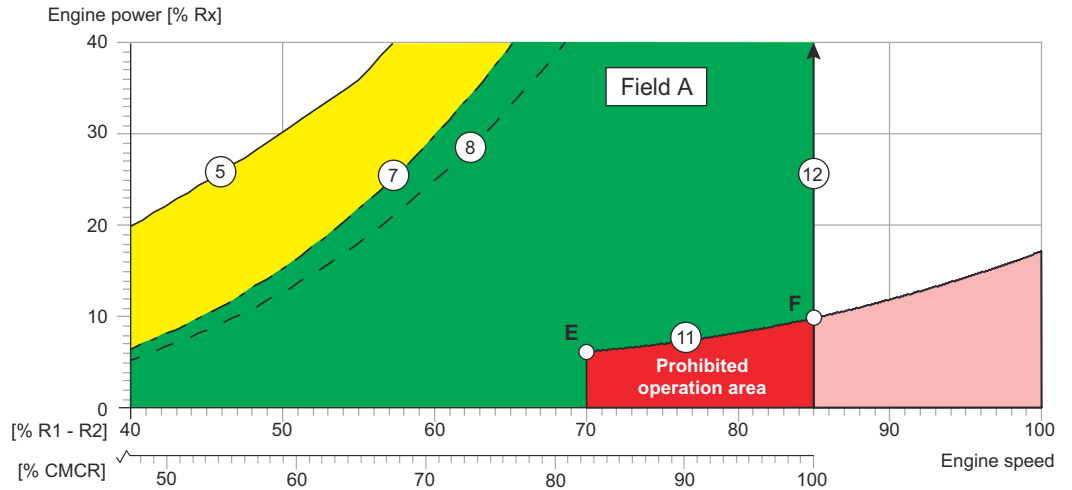

SM-0523

Figure 2-8 Calculating the prohibited operation area for the CMCR speed

Figure 2-8 shows an engine with a CMCR speed which is rated at 85% of the R1—R2 speed and therefore is only affected by a portion of the prohibited area of the R1—R2 speed range. The final graph for a CMCR at this speed is shown in Figure 2-9, 2-16.

Power / speed range for
CMCR [Rx] =
85% R1—R2 speed

In Figure 2-9, the engine’s CMCR speed is rated at 85% of the R1—R2 speed. At this speed, a minimum engine power (point F) of 10.4% is required, below this is the prohibited area of operation for the CPP at small (to zero) pitch and disconnected propeller.

Point E is always defined at 70% of the R1—R2 speed and has a minimum power of 5.8%, however in Figure 2-9 this equates to approximately 82% CMCR speed.

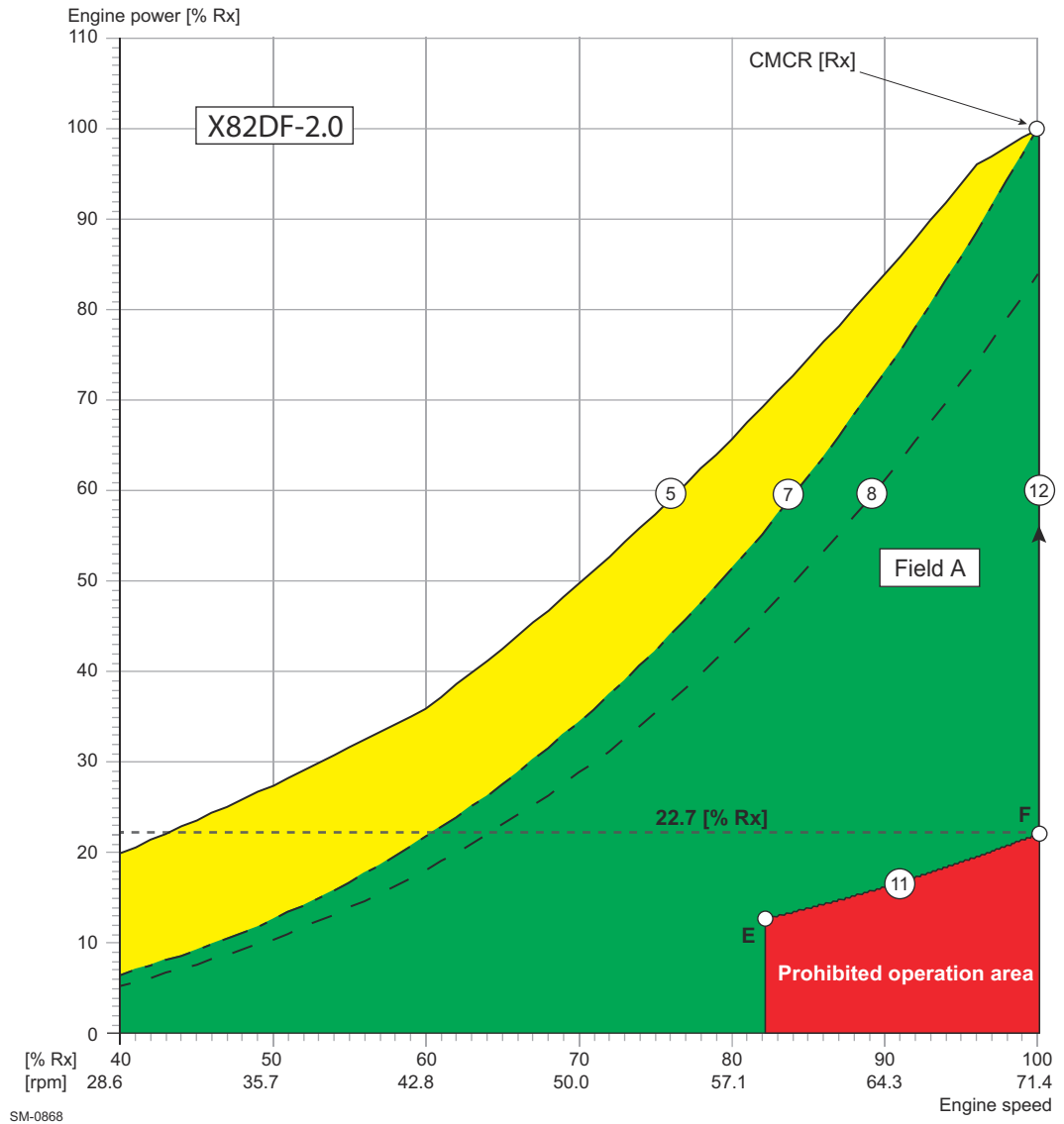

Figure 2-9 The prohibited operation area (CMCR speed = 85% of R1—R2)

**Power / speed range for
CMCR [Rx] =
R3—R4 speed**

In **Figure 2-10**, the engine's CMCR speed is rated at the R3—R4 speed. At this speed, a minimum engine power (point F) of 7.9% is required. Below this is the prohibited area of operation for a disconnected propeller.

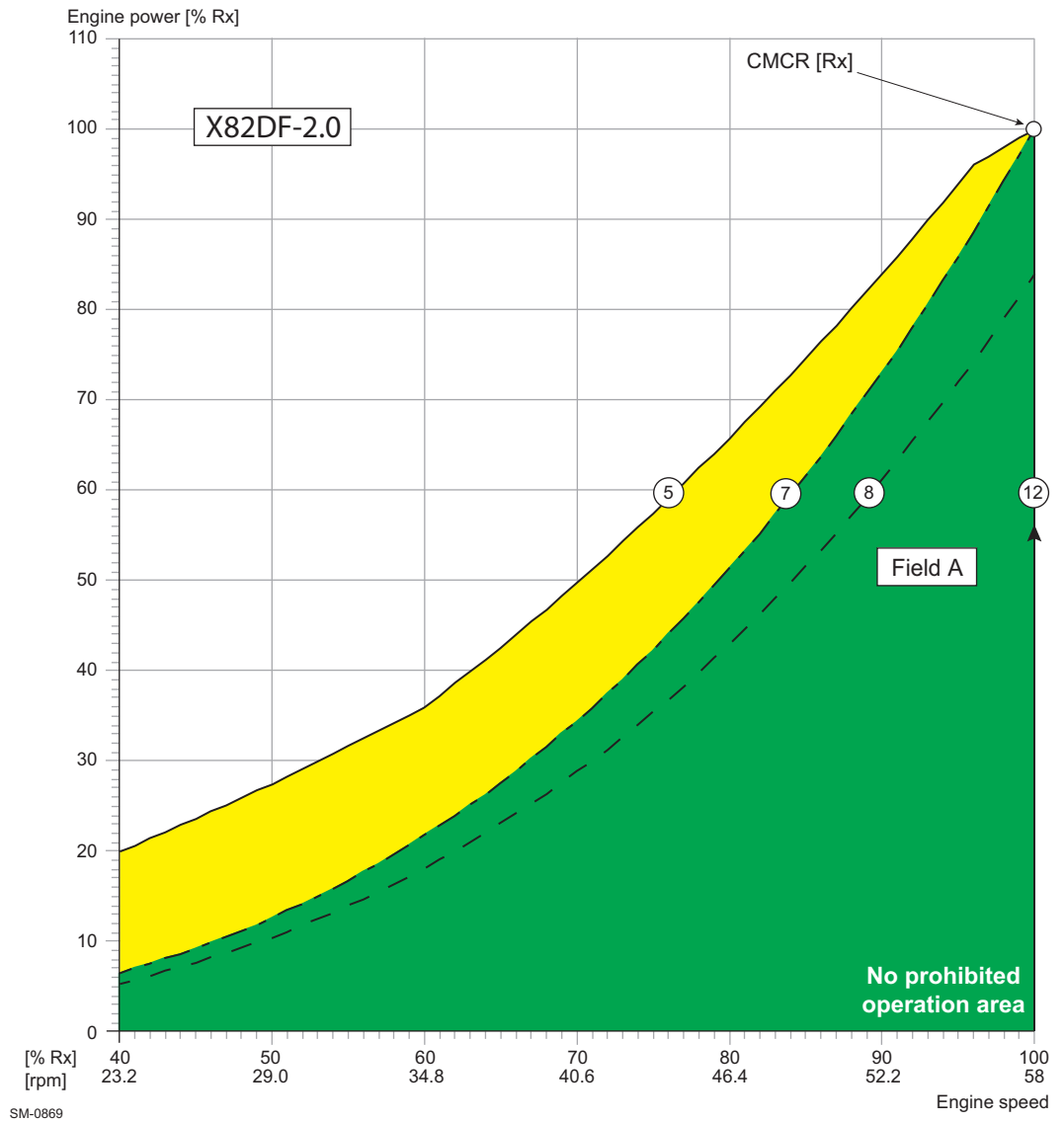

Figure 2-10 The prohibited operation area (CMCR speed = R3—R4)

3 Engine Installation

The purpose of this chapter is to provide information to assist in the installation of the engine. It is for guidance only and does not supersede current instructions.

3.1 Engine dimensions and masses

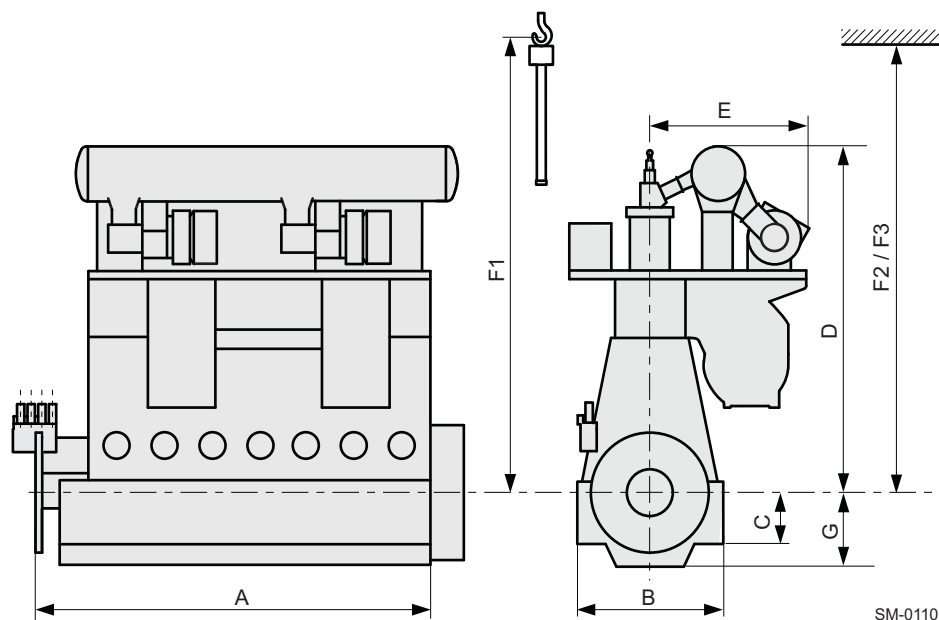

Figure 3-1 Engine dimensions

Table 3-1 Engine dimensions and masses

No. cyl.	Dimension in mm with a tolerance of approx. ± 10 mm							Net eng. mass ^{a)} [tonnes]
	A	B	C	D	E	F1 ^{b)c)}	G	
6	10,425	5,050	1,800	12,310	Dim. depending on TC type	15,150	2,700	805
7	11,865							910
8	13,305							1,020
9	14,745							1,160
Min. capacity of standard crane: 12,500 kg								

- a) Without oil/water; net engine mass estimated according to nominal dimensions given in drawings, including turbocharger and SAC, piping and platforms
 b) Min. height for vertical removal of piston with standard crane
 c) Dimensions F2 and F3 on request

NOTE

The dimensions and masses provided in the above table are not binding. For prevailing data refer to the relevant drawings, which are updated on a regular basis.

Project-specific dimensions and masses for the main components are to be requested from the engine builder.

The iCER installation data are provided in section [4.2 The iCER technology](#), [4-4](#).

3.1.1 Drawings and 3D CAD model availability

Over the course of engine development, design groups become available with improving timeline accuracy. Initial concept design groups available for early engine development stages will be updated to final concept design groups at the end stage. Concept design and final design groups can be mixed, however, final design groups contain more accurate data and supersede concept design groups.

In addition to existing drawings, 3D CAD outline models for specific engines are available on WinGD's webpage.

Table 3-2 Design groups of shipyard drawings and 3D CAD models

Design Group	Title	MIM section
0812-01	Engine Outline View – Concept	3.2
0812-02	Engine Outline View	3.2
0816-01	Dismantling Dimensions – Concept	3.1.2
0816-02	Dismantling Dimensions	3.1.2
7602-01	Platform Outline View – Concept	3.3
7602-02	Platform Outline View	3.3
8020	Pipe Connection Plan	4.12.1
9715	Engine Stays	3.8

3.1.2 Dismantling dimensions

Dimensions F1, F2, F3 in [Figure 3-1](#), [Fig 3-1](#) and the corresponding table are only for guidance and may vary depending on crane dimensions, handling tools or dismantling tolerances. If these values cannot be met or if more detailed information is required, please contact WinGD.



For details see 'Dismantling Dimensions – Concept' (DG 0816-01) and final 'Dismantling Dimensions' (DG 0816-02) provided on the WinGD webpage under the following link:

[Drawings → Dismantling Dimensions](#)

3.1.3 Crane requirements

- An overhead travelling crane is to be provided for normal engine maintenance (see [Table 3-1](#), [Fig 3-1](#) for crane capacity)
- The crane is to conform to the requirements of the classification society

NOTE

As a general guidance for crane speeds, WinGD recommends the following:

- A two-speed hoist with a low-speed mode of 0.2-0.8 m/minute and a high-speed mode of 2.0-8.0 m/minute
- A two-speed horizontal movement with a low speed mode of 1.0-4.0 m/minute and a high-speed mode of 4.0-8.0 m/minute

3.1.4 Thermal expansion between the turbocharger and exhaust gas piping

Before making expansion pieces, enabling connections between the engine and external engine services, the thermal expansion of the engine and turbocharger has to be taken into account. The engine expansion is defined (from ambient temperature 20°C to service temperature 55°C) as follows (see also Figure 3-2):

Expansion	Distance from ...
Transverse expansion (X)	... crankshaft centreline to centre of gas outlet flange
Vertical expansion (Y)	... bottom edge of bedplate to centre of gas outlet flange
Longitudinal expansion (Z)	... engine bedplate aft edge to centre of gas outlet flange

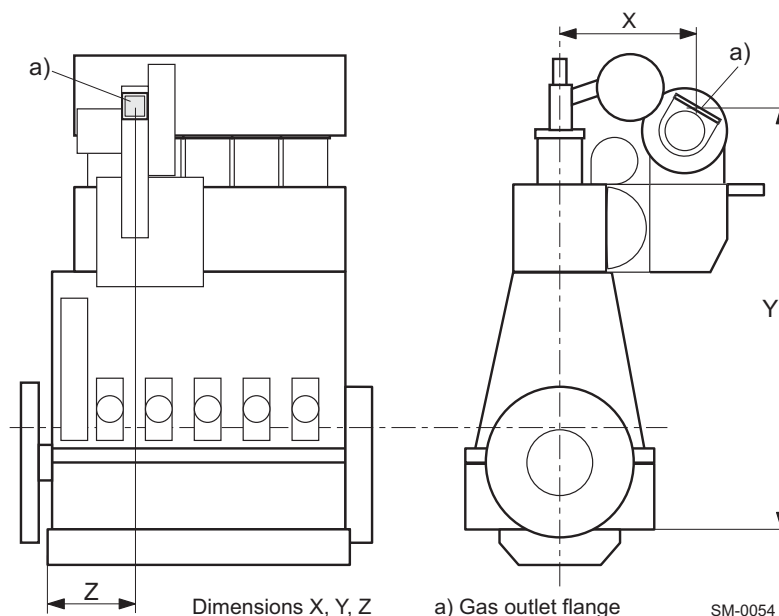

Figure 3-2 Thermal expansion, dim. X, Y, Z

Calculating thermal expansion

$$\Delta x (\Delta y, \Delta z) = X (Y, Z) \cdot \alpha \cdot \Delta T$$

where:

$\Delta x, \Delta y, \Delta z ..$ = thermal expansion

X, Y, Z = distance as per relevant pipe connection plan and outline drawing

α = $1.15 \cdot 10^{-5}$ (coefficient of thermal expansion)

ΔT = difference between service temp. and ambient temp. [°C]

NOTE

For thermal expansion values of the turbocharger, please see the specifications of the turbocharger maker.

3.1.5 Content of fluids in the engine

For the quantity of a specific fluid in the engine please refer to the relevant MIDS drawings as listed below:

- Fuel oil — *Fuel oil system*
- Lubricating oil — *Lubricating oil system*
- Cylinder cooling water — *Cooling water systems*
- Freshwater in scavenge air cooler — *Cooling water systems*

3.2 Engine outline views



For the engine outline views see '**Engine Outline View – Concept**' (DG 0812-01) and final '**Engine Outline View**' (DG 0812-02) provided on the WinGD webpage under the following link:

Drawings → *Engine Outline View*

3.3 Platform outline views



For the platform arrangements see 'Platform Outline View – Concept' (DG 7602-01) and final 'Platform Outline View' (DG 7602-02) provided on the WinGD webpage under the following link:

[Drawings → Platform Outline View](#)

3.3.1 Minimum requirements for escape routes

The platforms are arranged in such a way to ensure safe escape routes for the crew according to the minimum requirements of classification societies. Special attention must be given to ensure minimum distance (sufficient headroom) between the ship's platform and the lower engine platform (see [Figure 3-3](#)).

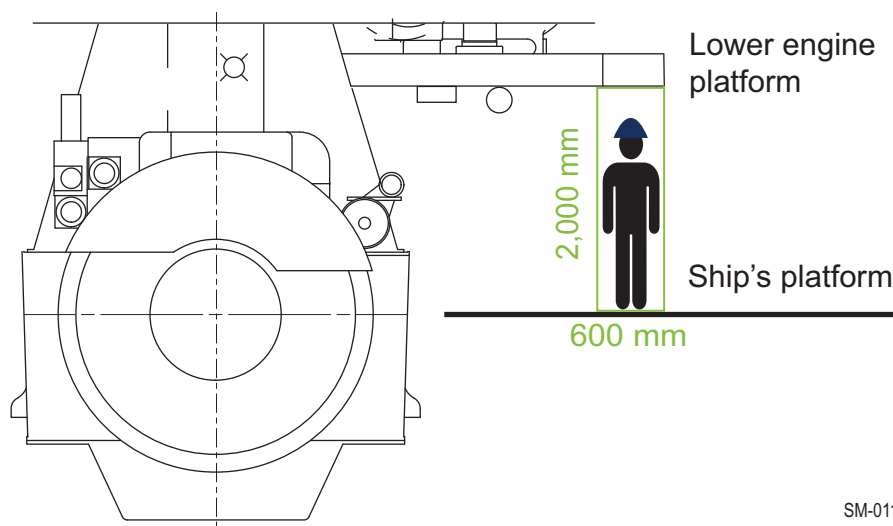

SM-0115

Figure 3-3 Minimum requirements for headroom

NOTE

The dimensions and distance between the ship's platform and the lower engine platform must conform to the minimum requirements of classification societies.

No dead ends may be created on engine platforms by shipboard installations. If a dead end cannot be prevented, then an escape route leading to the ship's platform must be made before the dead end. The maximum distance to the escape route must be 2,000 mm.

3.4 Engine foundation and seating

3.4.1 Engine load and force transmission

The engine seating foundation is a structural part of the ship integrated into the double-bottom structure. It must be designed to absorb static and dynamic forces, vibrations and torques from the engine, shaft and the propeller.

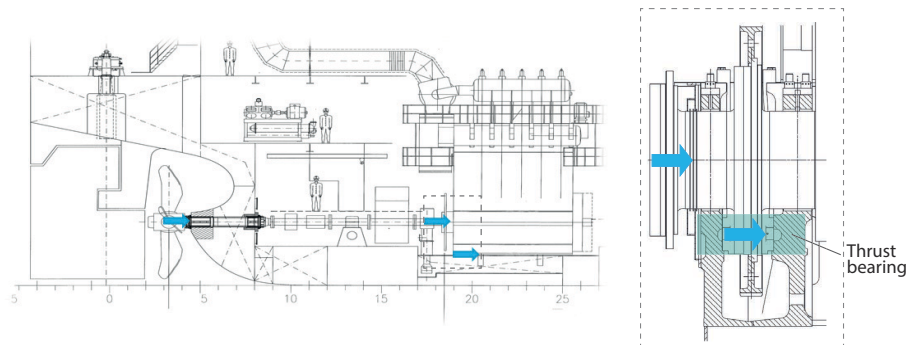

SM-0824

Figure 3-4 Force transmission to the engine foundation

The propulsion thrust is transmitted along the propulsion chain to the engine structure through the thrust bearing. Thrust sleeves are required to absorb the thrust force. In addition, the dynamic behaviour of engine forces requires a stiff engine seating foundation (see the standard bolting in [Figure 3-6](#), [3-9](#)).

3.4.2 Engine foundation layouts

Depending on the owner’s requirements and on the ship design, a standard or a narrow engine foundation layout are possible for the engine seating foundation. The main difference between the two engine foundation layouts is the width of the lube oil drain tank underneath the engine (see [Figure 3-5](#)).

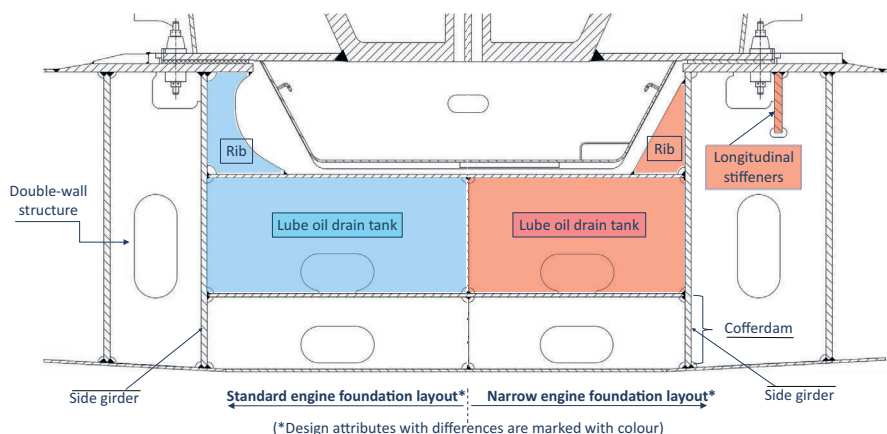

SM-0825

Figure 3-5 A comparison of the standard and narrow engine foundation layout

A summary of the advantages and disadvantages of the two engine foundation layouts is provided in [Table 3-3](#).

Table 3-3 Advantages and disadvantages for the standard and narrow engine foundation layouts

	Standard	Narrow
Advantages	<p>Forces transmitted to the side girder</p> <p>Dynamic stresses on the bed-plate welding seams are reduced</p> <p>Additional longitudinal stiffeners can be omitted</p> <p>Easier for welding activities and less material is required</p>	<p>Less width is required for the installation which enables engine installation in the aft-most position</p> <p>Less oil volume is required for the same filling height</p>
Disadvantages	<p>More width is required for the installation which limits the flexibility of the engine installation position</p>	<p>More complicated welding activities due to the narrow space caused by the longitudinal stiffener</p>

3.4.3 Engine installation and fixation

To ensure the fixing of the engine under all operating conditions, the engine must be effectively and permanently tightened down by foundation bolts. WinGD recommends the use of thrust sleeves at the driving end. It has proven to be an easy, quick, and cost-efficient method for force transmission. The thrust sleeve is fitted to the bottom plate of the engine bedplate and to the foundation top plate. It serves as an interface for the transmission of various forces. The holes in the foundation top plate are pre-machined (e.g. flame-cut) with a larger diameter than the thrust sleeve. The thrust sleeve in the hole of the foundation top plate is then fixed with epoxy resin (see [Figure 3-6](#), [Fig 3-9](#)). The foundation bolts are inserted in the thrust sleeve and tightened together with the same torque as the regular foundation bolts. Since thrust is transmitted by the thrust sleeves, no end stoppers are required.

For the engine fixation, foundation bolts are installed without the thrust sleeve assembly parts.

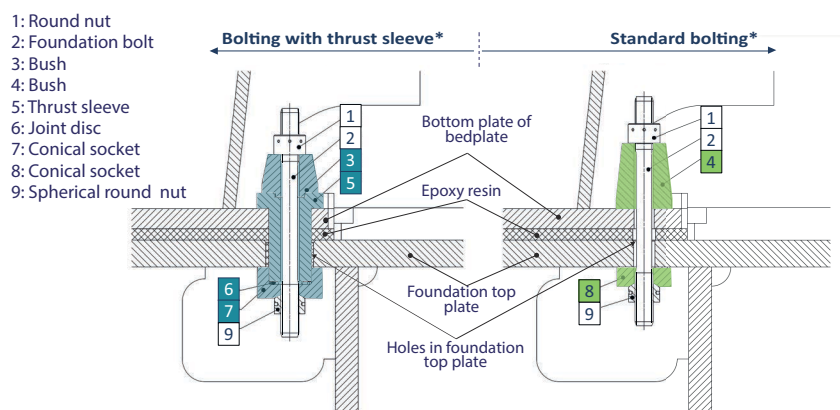

(*Design attributes with differences are marked with colour)

SM-0851

Figure 3-6 Foundation bolting

The classification society requires the use of side stoppers to prevent any lateral movement of the engine in case of collision. Different designs are possible for the side stoppers. WinGD proposes a welded type side stopper design (see [Figure 3-7](#)).

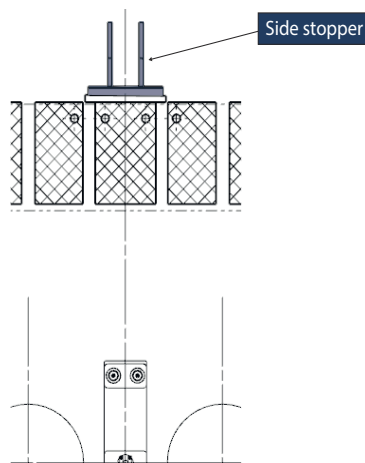

SM-0852

Figure 3-7 Welded type

The welding seam must be continuous over the entire length of the wedge (see [Figure 3-8](#), [3-10](#)). Specifications for the minimum numbers of side-stoppers and their positions are defined in the engine seating and foundation drawing. The minimum required contact surface of each wedge to the engine bedplate are also provided in the drawing.



The latest version of the **Marine Installation Drawing Set** relevant for the engine seating and foundation (DG 9710) is provided on the WinGD webpage under the following link:

[MIDS](#)

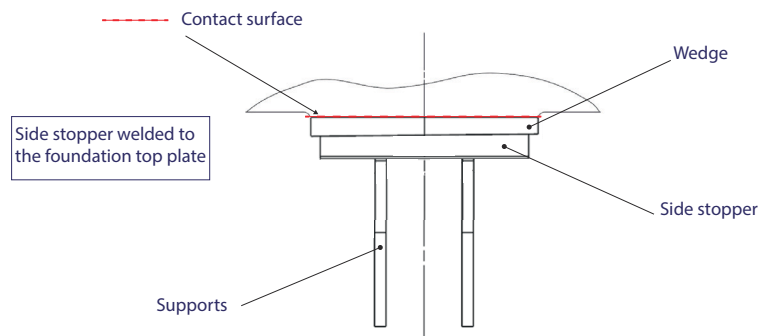

SM-0853

Figure 3-8 Side stopper installation arrangement



More details about engine seating can be found in the relevant **Fitting Instruction** (DG 9710) on the WinGD webpage under the following link:
[Fitting Instruction](#)

In some specific fitting conditions (e.g. when the foundation is directly connected to the bottom or to the cofferdam), the classification society requires the use of water-tight bolting for the engine fixation. In these cases, the use of water-tight bolting protects the engine room from the risk of flooding (see [Figure 3-9](#)).

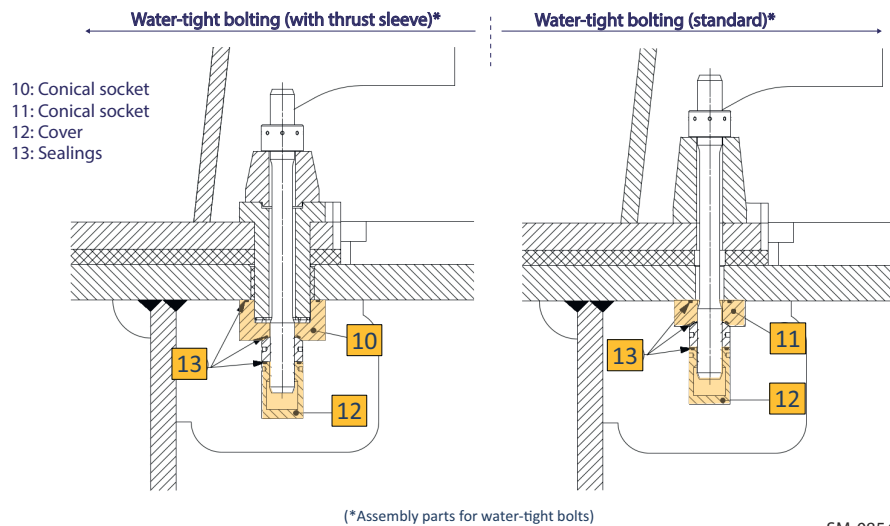

(* Assembly parts for water-tight bolts)

SM-0854

Figure 3-9 Proposed designs for water-tight bolting

3.5 Assembly

Engines may be installed as complete units or assembled from subassemblies in the vessel, which may be afloat, in dry dock, or on the slipway.

3.5.1 Assembly of subassemblies

When the engine seating has been approved, the bedplate is lowered onto blocks placed between the chocking points. The thickness of the blocks depends on the final alignment of the engine. Engine bedplates comprise fabricated sections with tapped holes for the jacking screws for engine alignment, and drilled holes to allow the passing of the holding-down bolts.

For checking the dimensions optical devices or lasers may be used

- Proceed with the preliminary alignment of the bedplate using wedges or jacking screws.
- Position the engine coupling flange to the intermediate shaft coupling flange.
- Ensure that the gap between both flanges is close to the calculated figures and that both flanges are exactly parallel on the horizontal plane (max. deviation 0.05 mm).
- In the vertical plane, set the engine coupling flange 0.4-0.6 mm higher than the calculated figures.
- Place the bearing caps in position and install the turning gear.
- Ensure that the crankshaft deflections are as recorded in the 'Engine Assembly Records'.
- Check the bedplate level in longitudinal and diagonal directions with a taut-wire measuring device provided by the engine builder.
- Compare the readings with those recorded at works.

All final dimensions are to be witnessed by the representatives of the engine builder and the classification society, and recorded on appropriate log sheets. Crankshaft deflections at this stage are to correspond with the values recorded at works.

- Temporarily secure the bedplate against unexpected movement.
- Continue engine assembly by mounting the columns, cylinder blocks, running gear and scavenge air receiver.
- Ensure that the bearing caps are loose before tensioning the tie rods.
- Make periodic checks of the crankshaft deflections to observe and correct any possible engine distortions.
- Carry out careful adjustments of the wedges or the jacking screws to re-establish the preliminary alignment setting.

NOTE

The process of using jacking screws and wedges is defined in [MIDS](#) and must be followed to prevent any damage.

Once the engine assembly is completed, the final alignment and chocking is carried out with the vessel afloat.

3.5.2 Installation of a complete engine

In the event that the engine is shipped in part deliveries and assembled at the shipyard before installation in the vessel, the shipyard is to undertake assembly work in accordance with the demands of a representative of the engine builder and the classification society.

NOTE

- Strict attention is to be paid to the removal of anti-corrosion coatings and the subsequent application of rust preventing oil where required.
- The alignment tools are to be clean and ready for use.

Please observe:

- Engine mounting is to be carried out systematically.
- The measurement readings have to be recorded on appropriate log sheets and compared for correctness with the data in the 'Engine Assembly Records' completed after test run in the manufacturer's works.
- The engine is to be lowered onto blocks placed between the chocking points.
- The blocks are to be set in such a manner that the engine is slightly higher than the final position, because less effort is required to lower the engine than to raise it for alignment.
- For movements in the horizontal plane, both in lateral or longitudinal directions, the shipyard is to construct appropriate anchor points for the use of hydraulic jacks. Such movements have to be carried out with great care to avoid stresses and distortions to the bedplate.
- Regular crankshaft deflection readings have to be taken to observe the effects, and any noticed deviation has to be rectified immediately.

3.5.3 Installation of an engine from assembled subassemblies

Subassemblies of the engine may be assembled ashore before installation in the ship. One such assembly may comprise the following components:

- Bedplate
- Main and thrust bearings
- Crankshaft
- Turning gear
- Flywheel

The placing on blocks and alignment to shafting is analogue to that described in section 3.5.1,  3-11.

3.5.4 Installation of an engine in ship on slipway

Installing a complete or partially assembled engine in a ship under construction on an inclined slipway is possible when careful attention is paid to the following:

- Large components suspended to take account of the incline
- Tie rods centred and exactly perpendicular to the bedplate before tightening.
- Side, fore and aft arresters temporarily fitted to prevent the engine from moving during launching of the ship
- Additional temporary stays attached at upper platform level to steady the engine during launching

3.6 Engine and shaft alignment

Alignment and chocking of the engine should be carried out in accordance with our recommendations and is subject to test and inspection by the relevant classification society.

Each stage of engine mounting is to be checked by qualified personnel and the measurements cross-checked with the design figures. In the event of discrepancies the responsible parties (e.g. shipyard) are to advise the representative of the engine builder or WinGD directly.

3.6.1 Instructions and limits

Alignment can be done with either jacking screws or wedges.



For detailed alignment procedures refer to the latest version of **Engine Alignment Documents** (DG 9709) provided on the WinGD webpage under the following link:

[Engine alignment](#)

3.6.2 Tools



For **Engine Alignment Tools** (DG 9710-01) refer to the latest version of the respective drawings, which are provided on the WinGD webpage under the following link:

[Tool engine alignment](#)

3.7 Engine coupling

3.7.1 Design

The design of coupling bolts and holes for the flange connection of crankshaft / propulsion shafts as provided by design group 3114 is included in the engine design approval by all major classification societies.

3.7.2 Machining and fitting of coupling bolts

- Before fitting the coupling bolts ensure that the mating flanges are concentric. Close the gap between the flanges completely by means of min. 4 temporary (non-fitted) bolts evenly distributed over the pitch hole diameter.
- Carry out drilling and reaming of engine and shaft couplings by means of a computer controlled drilling machine or an accurately centred jig.
- In the case of non-matching holes or damaged holes apply joint cylindrical reaming to an oversize hole and then fit an individually machined bolt.
- The bolts have to be available for inserting in the holes on completion of reaming. Each bolt is to be stamped with its position in the coupling, with the same mark stamped adjacent to the hole. The following tolerances have to be met:
 - bolt hole tolerance: H7
 - bolt tolerance: g6 (clearance fit)
- If there is any doubt that a fitted bolt is too slack or too tight, refer to the classification society surveyor and a representative of the engine builder.

3.7.3 Tightening

- When tightening the coupling bolts it is essential to work methodically. Perform crosswise tightening, taking up the threads on opposite bolts to hand-tight, followed by sequential torque tightening. Finally ensure the same proper tightening for all bolts.
- Mark each bolt head in turn (1, 2, 3, etc.) and tighten opposite nuts in turn according to the Tightening Instructions, making sure that the bolt head is securely held and unable to rotate with the nut.
- Lock castellated nuts according to Class requirements with either locking wires or split pins. Use feeler gauges during the tightening process to ensure that the coupling faces are properly mated with no clearance.

3.7.4 Installation drawing



The latest version of the drawing relevant for the **Connection Crank / Propeller Shaft** (DG 3114) is provided on the WinGD webpage under the following link:
[*Connection crank / propeller shaft*](#)

3.8 Engine stays

Ship vibrations and engine rocking caused by the engine behaviour (see chapter 6 [Engine Dynamics](#), § 6-1) are reduced by fitting lateral stays (refer to section 6.2 [External lateral forces and moments](#), § 6-5).



The latest version of the **Marine Installation Drawing Set** relevant for engine stays (DG 9715) is provided on the WinGD webpage under the following link:

[*MIDS*](#)

3.9 Propulsion shaft earthing

Electric current flows when a potential difference exists between two materials. The creation of a potential difference is associated with *thermoelectric* by the application of heat, *tribo-electric* between interactive surfaces, *electrochemical* when an electrolytic solution exists, and *electromagnetic induction* when a conducting material passes through a magnetic field.

Tracking or leakage currents are created in machinery by any of the above means and — if they are not adequately directed to earth — can lead to component failures, or in some cases result in fires and interference with control and monitoring instrumentation.

3.9.1 Preventive action

Using earthing brushes in contact with slip rings and bonding the chassis by braided copper wire are common ways of protecting electric machines. Where operating loads and voltages are comparatively low, the supply is isolated from the machine by an 'isolating transformer', often with handheld power tools. The build specification dictates the earthing procedure to be followed and the classification society is to approve the final installation.

On vessels with star-wound alternators the neutral is considered to be earth, and electrical devices are protected by automatic fuses.

Isolation of instrument wiring

Ensure that instrument wiring meets the building and classification society specifications and that it is shielded and isolated to prevent induced signal errors and short circuits.

In certain cases large items of machinery are isolated from their foundations, and couplings are isolated to prevent current flow, for instance when electric motors are connected to a common gear box.

Retrospective fitting of earthing devices is not uncommon, but due consideration is to be given at design stage to adequate shielding of control equipment and earthing protection where tracking and leakage currents are expected. Magnetic induction and polarisation are to be avoided and degaussing equipment incorporated if there is likely to be a problem.

3.9.2 Earthing device

Figure 3-10, 3-17 shows a typical shaft earthing device.

The slip ring (1) is supplied as matched halves to suit the shaft, and secured by two tension bands (2) using clamps (12). The slip ring mating faces are finished flush and butt jointed with solder. The brushes (4) are housed in the twin holder (3) clamped to a stainless steel spindle (6), and there is a monitoring brush (11) in a single holder (10) clamped to an insulated spindle (9). Both spindles are attached to the mounting bracket (8).

Conducting material for slip rings

Different combinations of conducting material are available for the construction of slip rings. However, alloys with a high silver content are found to be efficient and hard wearing.

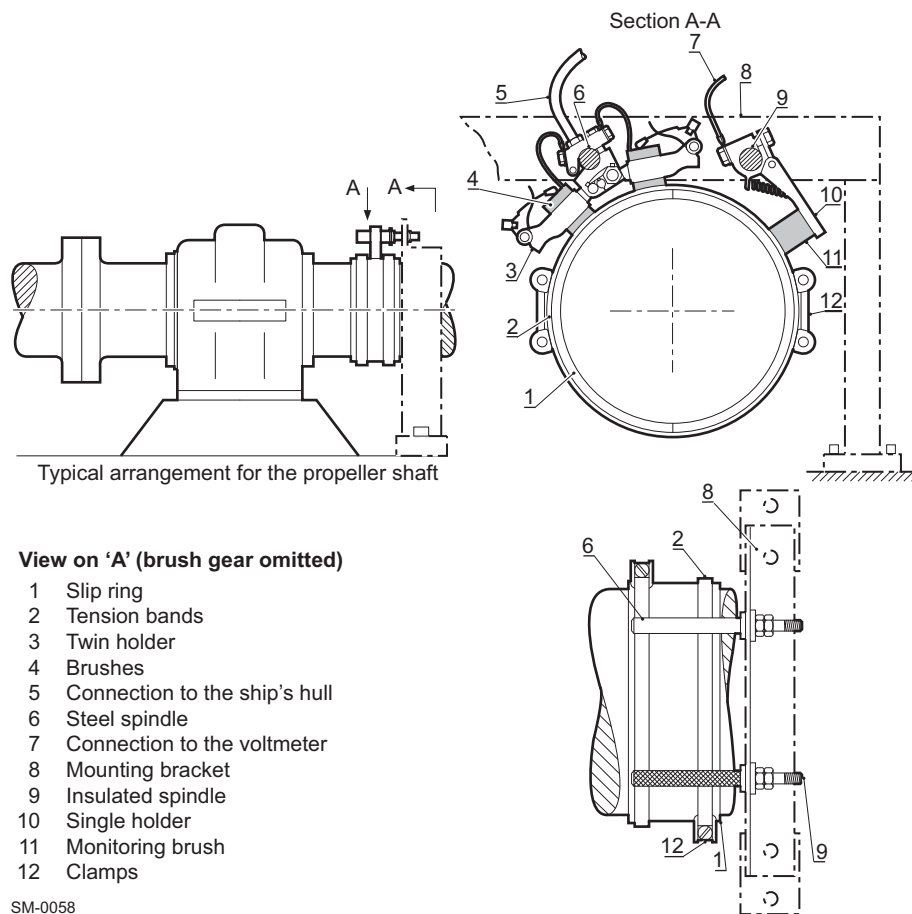

Figure 3-10 Typical shaft earthing arrangement

Position of earthing device on shaft

The position of the earthing device must be as close as possible to the main engine's flywheel. For installation of a PTO/PTI/PTH on the driving end side, the earthing device must be placed between the PTO/PTI/PTH and the main engine's flywheel.

NOTE

An additional earthing device might be required to protect the shaft bearings and the stern tube bearings. For detailed information please contact the earthing device supplier.

Connecting electric cables

The electric cables are connected as shown in [Figure 3-11](#), [3-18](#) with the optional voltmeter. This instrument is at the discretion of the owner, but it is useful to observe that the potential to earth does not rise above 100mV.

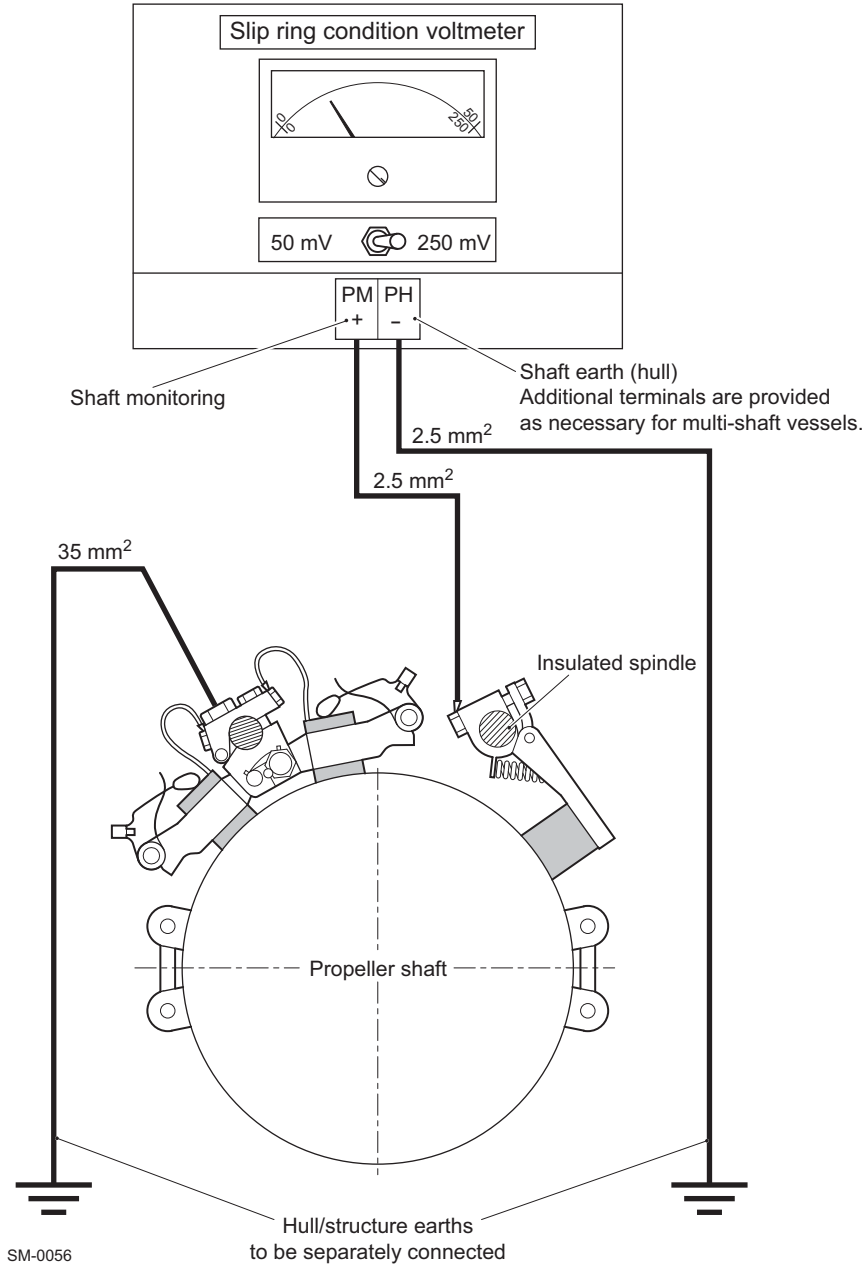
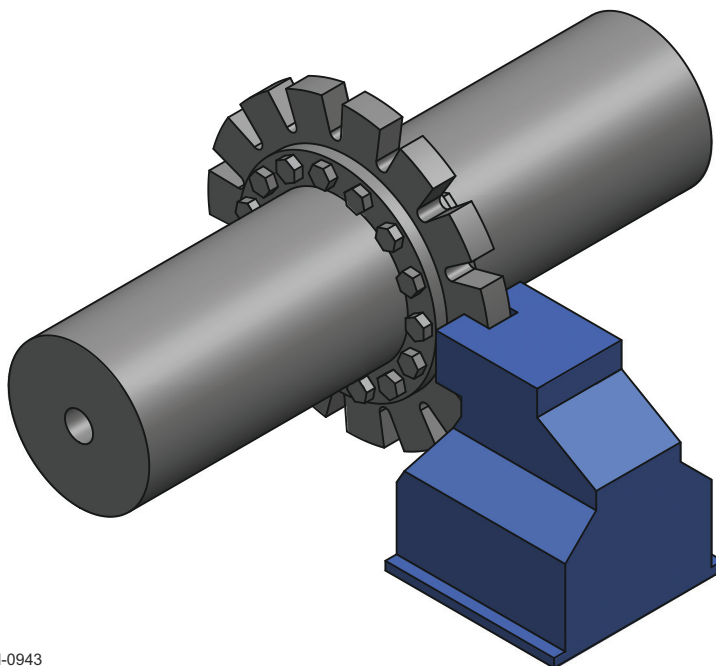

Figure 3-11 Typical shaft earthing with condition monitoring facility

3.10 Twin-engine propulsion

Twin engines are used in many applications depending on design rules and customer requirements. This layout offers increased system redundancy, permitting one engine to be taken out of service without disabling the ship. Such work is common during a port stay with one engine on standby, while maintenance is performed on the other.

WinGD recommends that a shaft-locking device is added to all twin-engine installations (see [Figure 3-12](#)).



SM-0943

Figure 3-12 Example of a shaft-locking device

NOTE

During ship design, the impact of vibration by operating the vessel with one shaft locked or windmilling must be considered. The torsional vibration loads must be checked with a Torsional Vibration Calculation (TVC). For further details, please see section 6.4, [6-13](#).

3.11 Fire protection

Fires may develop in areas such as scavenge air receiver / piston underside. The engine is fitted with a piping system which leads the fire extinguishing agent into the critical areas.

Where fire protection is required, the final arrangement of the fire extinguishing system is to be submitted for approval to the relevant classification society.

Extinguishing agents

Various extinguishing agents can be considered for fire fighting purposes. They are selected either by the shipbuilder or the ship owner in compliance with the rules of the classification society involved.

Steam as an alternative fire extinguishing medium is permissible for the scavenge air spaces of the piston underside, but may cause corrosion if countermeasures are not taken immediately after its use.

These countermeasures comprise:

- Opening scavenge spaces and removing oil and carbon deposits
- Drying all unpainted surfaces and applying rust protection (i.e. LO)

NOTE

If steam is used for the scavenge spaces, a water trap is recommended to be installed at each entry to the engine and assurance obtained that steam shut-off valves are tight when not in use.

Table 3-4 Recommended quantities of fire extinguishing medium

Piston underside and scavenge air receiver		Bottle		Number of cylinders			
				6	7	8	9
Volume [m ³ /cyl]	Mass [kg/cyl]	Size [kg]	Extinguishing medium	Quantity of fire extinguishing bottles			
10	36	45	Carbon dioxide (CO ₂)	5	5	6	7

3.12 Conditions and requirements

3.12.1 Pressure and temperature ranges



Please refer to the document ‘**Usual values and safeguard settings**’, which is provided by WinGD under the following link:

[Usual values and safeguard settings](#)

For signal processing see also [5.6.1 Signal processing](#), ¶ 5-11.

3.12.2 Operating conditions

The engine can be operated without any restrictions in the ambient condition range ‘winter’, as permissible by *GTD*, up to design conditions. Operation outside these limits is possible, but further measures might need to be taken and the power output might be limited (see [4.11.4 Outside ambient air temperature](#), ¶ 4-122). For project-specific support please contact WinGD.

Reference conditions

Engine performance data — like BSEC, BSEF, tEaT and others — are based on reference conditions. These conditions are specified in ISO standard 15550 (core standard) and, for marine application, in ISO standard 3046 (satellite standard) as follows:

Air temperature before blower:	25 °C
Engine room ambient air temperature:	25 °C
Coolant temperature before SAC:	25 °C
Barometric pressure:	1,000 mbar
Relative humidity:	30 %

Design conditions

The capacities of ancillaries are specified according to ISO standard 3046-1 (clause 11.4) following the International Association of Classification Societies (IACS) and are defined as design conditions:

Air temperature before blower:	45 °C
Engine room ambient air temperature:	45 °C
Coolant temperature before SAC:	36 °C
Barometric pressure:	1,000 mbar
Relative humidity:	60 %

3.12.3 Ancillary systems design parameters

The layout of the engine's ancillary systems is based on the engine's rated performance (rating point Rx, CMCR). Several parameters must be considered to ensure proper function of the engine and its ancillary systems.

Cylinder cooling water and system oil temperatures

The cylinder cooling water outlet and system oil inlet temperatures must be controlled in the relevant ancillary system to remain within specified levels.

Cylinder cooling water outlet temperature:	90 °C
Oil temperature before engine:	45 °C

Exhaust gas back pressure

The below back pressures correspond to the pipe connection of the iCER return pipe.

Design exhaust gas back pressure in diesel Tier II mode at rated power (Rx):	From 30 to 60 mbar
Operational limit:	80 mbar
Design exhaust gas back pressure in iCER gas mode at rated power (Rx):	
• Design limit:	From 30 to 45 mbar
• Operational limit:	55 mbar
Exhaust gas back pressure in iCER diesel Tier III mode at rated power (Rx):	Not relevant for layout

Diesel Tier II mode

Description of the back pressure specifications

In this mode, all exhaust gas passes through the main exhaust pipe via the main economiser to the funnel. For X-DF2.0 engines, no additional exhaust gas after treatment systems are foreseen. The exhaust gas back pressure has a direct influence on the engine efficiency and should therefore be minimised. However, to enable installation of a main economiser which is also highly efficient during iCER operation (during which the exhaust gas flow to the funnel is reduced due to the iCER recirculation), the back pressure limit can be increased from the standard value of 30 mbar to 60 mbar.

iCER gas mode

In this mode, exhaust gas flow to the funnel is reduced due to iCER recirculation, resulting in much lower back pressure than the diesel Tier II design limit. Rather, the iCER system back pressure is relevant for this operating mode.

3.12.4 Electrical power requirement

Table 3-5 Electrical power requirement

No. cyl.	Power requirement [kW]	Power supply
Auxiliary blowers^{a)}		
6	2 x 110	440V / 60Hz
7	2 x 131	
8	2 x 151	
9	2 x 166	
Turning gear		
6	11	440V / 60Hz
7	11	
8	15	
9	15	
Engine control system		
6	0.9	220V / 60Hz
7	1.0	
8	1.1	
9	1.2	
Pilot fuel pump		
All	12.8	440V / 60Hz
Trace heating of cylinder lubricating oil pipes^{b)}		
6	1.0	220V / 60Hz
7	1.1	
8	1.3	
9	1.4	
Propulsion control system		
All	Acc. to maker's specifications	24VDC (UPS)
Additional monitoring devices (e.g. oil mist detector, etc.)		
All	Acc. to maker's specifications	

a) Minimal electric motor power (shaft) is indicated. Actual electric power requirement depends on size, type and voltage/frequency of installed electric motor. Direct starting or Star-Delta starting to be specified when ordering.

b) The values provided are only for the on-engine pipes. The engine provides the possibility to connect an external trace heating cable of up to 80 m (which corresponds to the 16 A circuit breaker rating).

4 Ancillary Systems

Sizing the ancillary systems of the engine, i.e. for freshwater cooling, lubricating oil, fuel oil, etc., depends on the contracted maximum engine power. If the expected system design is out of the scope of this manual, then contact our representative or WinGD directly.



The *GTD* application provides data for estimating the size of ancillary equipment and enables all engine and system data at any Rx rating within the engine rating field to be obtained. However, for convenience or final confirmation when optimising the plant, WinGD provides a computerised calculation service.

All pipework systems must be flushed and proved clean before commissioning

All pipework systems and fittings are to conform to the requirements laid down by the legislative council of the vessel's country of registration and the classification society selected by the owners. They are to be designed and installed to accommodate the quantities, velocities, flow rates and contents identified in this manual, set to work in accordance with the build specification as approved by the classification society and protected at all times from ingress of foreign bodies.

4.1 Twin-engine installation

A vessel equipped with two separate main propulsion engines is considered a twin-engine installation. The installation of two WinGD 2-stroke engines allows combining individual engine auxiliary systems. WinGD provides information based on engines' requirements (see Table 4-1). Class and other binding rules might overrule.

Table 4-1 Common and independent systems in twin-engine installations

System	Independent system for each engine required	Common system possible	Remarks
EGC circulation water system (see Figure 4-4, 4-6 and Figure 4-8, 4-16)	X		Independent exhaust gas coolers
		X	The EGC circulation water system, including the EGC circulation water tank
EGC circulation water treatment system (see Figure 4-8, 4-16)		X	
LT cooling water system (see Figure 4-1, 4-3)		X	Note: Parallel independent LT cooling water supply per engine to the scavenge air cooler from common LT cooling water circuit
		X	Note: Parallel independent LT cooling water supply per engine to the LO cooler and HT cooling water cooler from common LT cooling water circuit
HT cooling water system	X		
Main LO system	X		
Cylinder LO system (see Figure 4-25, 4-46 and Figure 4-26, 4-47)		X	Day tanks for high- resp. low BN lubricating oil
		X	Rising pipe
	X		Separate distribution to each engine
Fuel oil system	X ^{a)}	X ^{b)}	Feed system
	X	(X)	Booster circuit systems
Air supply system	X		
Control air		X	Supply system
Leakage collection system and washing devices	X		
Exhaust gas system	X		
Engine venting pipes	X		
X = proven solution (X) = alternative solution, if specific conditions are met			

- a) Independent systems required if a fuel flexibility for both engines is specified, meaning that the engines can independently operate in gas mode, fuel sharing mode or diesel mode. Main injector fuel can be MGO, MDO or HFO in fuel sharing mode and diesel mode.
- b) Common system possible if no fuel flexibility is specified, meaning that both engines can only run with the same main injector fuel, i.e. if one engine operates in gas mode, the other engine cannot operate with HFO as main injector fuel.

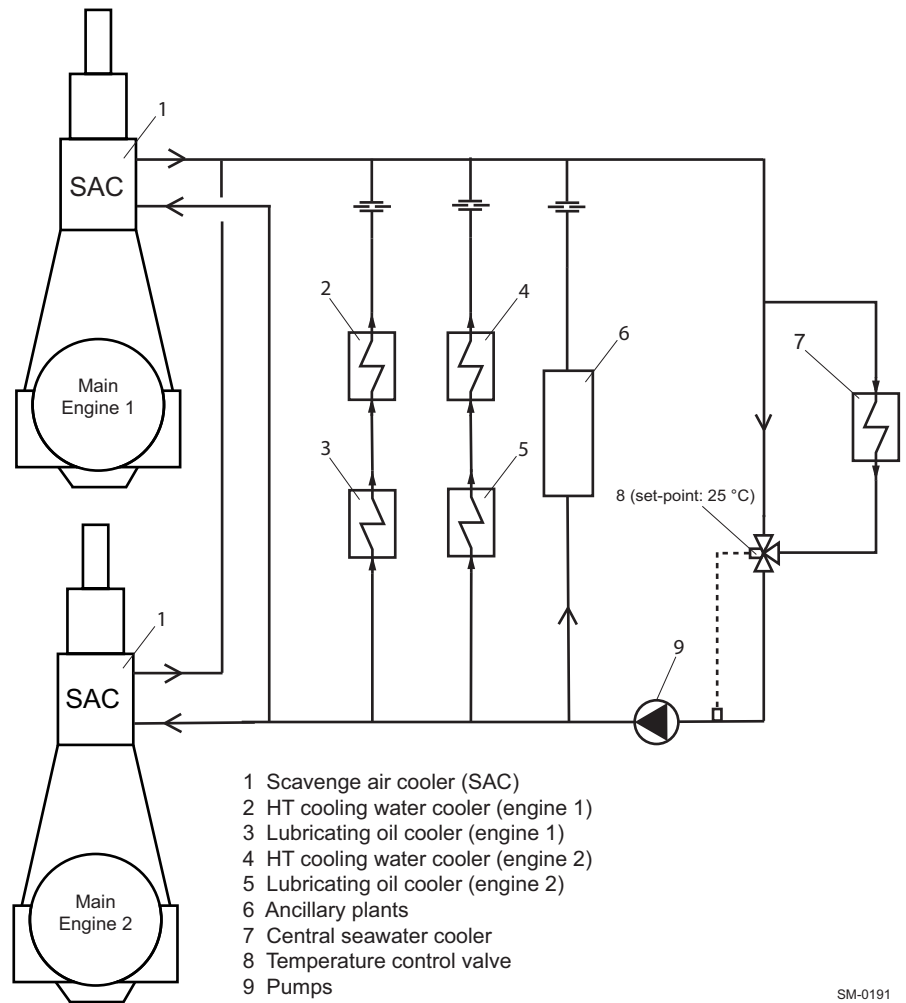

SM-0191

Figure 4-1 LT cooling water system for twin-engine installation

4.2 The iCER technology

This engine is equipped with the Intelligent Control by Exhaust Recycling (iCER) system. This facilitates the recirculation of part of the exhaust gas back to the engine. By replacing some of the oxygen with CO₂, the stability of the engine combustion is increased. This allows for an increase in the engine pressure ratio and a resulting increase in combustion efficiency.

This engine can also be selected with iCER operation in diesel Tier III mode (see [iCER operating mode options](#), 1-1). In this case, exhaust gas recirculation is used to reduce the NO_x emissions.

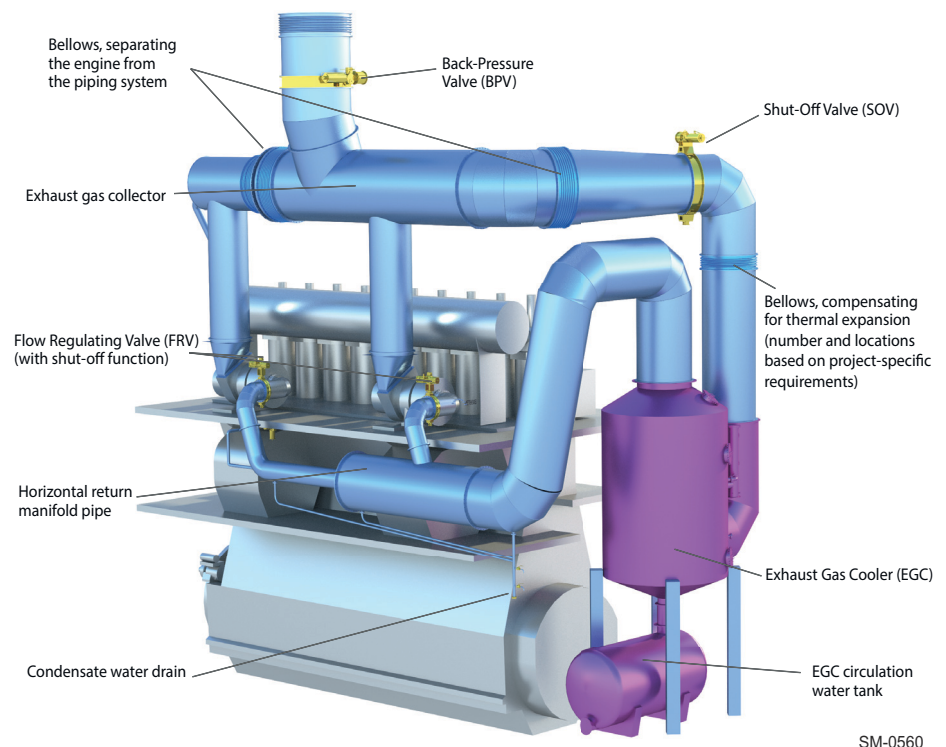

Figure 4-2 Overview of the components for the iCER system



For further details on the iCER installation such as the initial system cleaning, functional description and specific calculations, see the [iCER Installation Guideline](#)

4.2.1 The iCER description

The iCER system redirects part of the exhaust gas after the turbocharger. The exhaust gas temperature is then lowered by the Exhaust Gas Cooler (EGC), before passing through the turbocharger again at the compressor inlet. Finally, the exhaust gas passes through the scavenge air receiver (via the inlet). This exhaust gas reduces the amount of oxygen flowing into the engine, acting as an inert gas on the combustion.

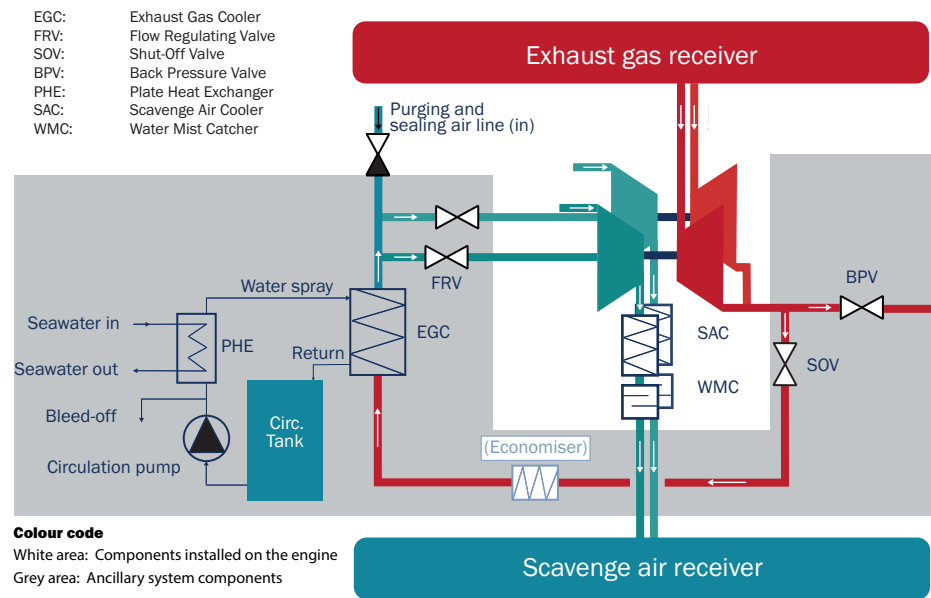

SM-0774

Figure 4-3 The iCER system with the exhaust gas return pipe routed to the turbocharger connection from below

The iCER system is positioned next to the main engine. It recirculates part of the exhaust gas after the turbine (along a low-pressure path) through the EGC and back to the compressor inlet. The exhaust gas and the fresh air are mixed before entering the turbocharger at the compressor inlet. For further information, see section 4.2.5 The iCER exhaust gas system, 4-22. The amount of returned exhaust gas is regulated in a closed loop control with a maximum possible exhaust gas recirculation of approximately 50%. Compared to a high-pressure path, the low-pressure path allows the turbocharger to run at full capacity.

The EGC cools the exhaust gas before it re-enters the turbocharger. The EGC produces a constant water spray that absorbs a majority of the heat as the exhaust gas passes through it. This process also cleans the exhaust gas. After this, the exhaust gas passes through the second cooling stage of the EGC, which is comprised of heat exchange surfaces made of steel. For all iCER system installations, the exhaust gas return pipe is routed to the turbocharger connection from below, and there is no WMC installed. This prevents condensate water from being carried over to the turbochargers. Condensate water drains must be arranged at the lowest point of the horizontal return manifold pipe. Different vessel trim conditions must be considered.

For the water treatment system see section 4.2.2 The EGC circulation water system, 4-6 and section 4.2.3 The iCER drainage system, 4-8.

4.2.2 The EGC circulation water system

For the general cooling water system description, refer to section 4.3, [4-28](#).

The EGC circulation water system is used to cool the recirculated exhaust gas by means of the Exhaust Gas Cooler (EGC) circulation water. In the WinGD documentation, the cooling water of the EGC circulation water system is referred to as EGC circulation water. This helps to distinguish between the engine cooling water and the cooling water of the iCER system. After initial filling of the EGC circulation water tank, the EGC circulation water is mainly generated from condensation water within the system. There is no EGC circulation water treatment with corrosion inhibitors necessary as is required for the low- and high-temperature cooling water system (see sections [4.3.1 Low-temperature circuit, 4-29](#) and [4.3.2 High-temperature circuit, 4-33](#)).

The primary component of this process is the EGC, which uses a two-stage cooling process as the exhaust gas passes through it. In the first stage, the exhaust gas is cooled by an EGC circulation water spray. In the second stage, the exhaust gas is cooled further by passing through heat exchanging filling material which is also supplied with an EGC circulation water spray (see section [4.2.1 The iCER description, 4-5](#)).

This EGC circulation water used by the EGC is captured and circulated through the water system. The EGC circulation water tank stores this water which is continually produced from condensation. The water is circulated through the system and cooled by heat exchanger, before re-entering the EGC. The set-point that controls the seawater flow, affecting the temperature of the EGC circulation water, is managed by the iCER control system. This arrangement limits the temperature reduction in winter conditions.

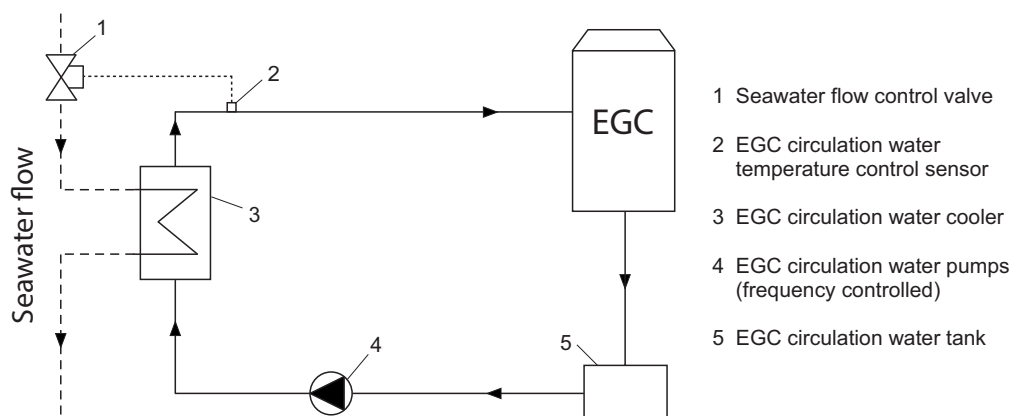

SM-0578

Figure 4-4 The EGC circulation water system

The cooling process reduces the temperature of the exhaust gas to approximately 40°C, which is below the dew point. Below the dew point, water starts to condensate out of the exhaust gas, and is then used in the system. This can lead to excess water in the system, which is then collected and discharged from the EGC circulation water tank to a drain tank (see section [4.2.3 The iCER drainage system](#), [4-8](#)).

For further details about the EGC circulation water system, including the size specification for the EGC circulation water tank, see the [MIDS](#). The EGC circulation water pump values for pressure and volumetric flow are determined by the EGC (for pump capacities refer to the [GTD](#)).

4.2.3 The iCER drainage system

For the leakage collection system and washing devices, refer to section 4.9, [4-106](#).

During iCER operation, the iCER drainage system handles all the condensate water from the EGC and the SAC. This water is generated by the EGC cooling of the exhaust gas in the iCER system. This specifically occurs during gas mode operation and under most conditions of diesel Tier III mode operation. This water is used in the EGC (see section 4.2.2, [4-6](#)) and collected in the EGC circulation water tank.

The iCER drainage system includes a water treatment system, a pH-neutralisation and dosing system, as well as water holding tanks. The dosing system includes the NaOH tank, the pump unit, as well as the monitoring and control unit. The water treatment system, including the pump unit and the water treatment unit, must be designed in such a way that a maximum solids content of 150 mg/l is maintained in the EGC circulation water.

The material of the drainage components must be selected according to the pH level of the fluids flowing through the components.



For further details about the functional description of the iCER system, see the *iCER Installation Guideline*

Arrangement of the iCER drainage system for installations which run the iCER system exclusively in gas mode

The initial design for iCER projects which run the iCER system exclusively in gas mode and were contracted before April 2022 provides water treatment for the bleed-off water and the SAC drain water. During iCER operation, the water treatment is carried out by means of a water treatment unit.

Figure 4-5 provides a sketch of the iCER drainage system for installations which run the iCER system exclusively in gas mode.

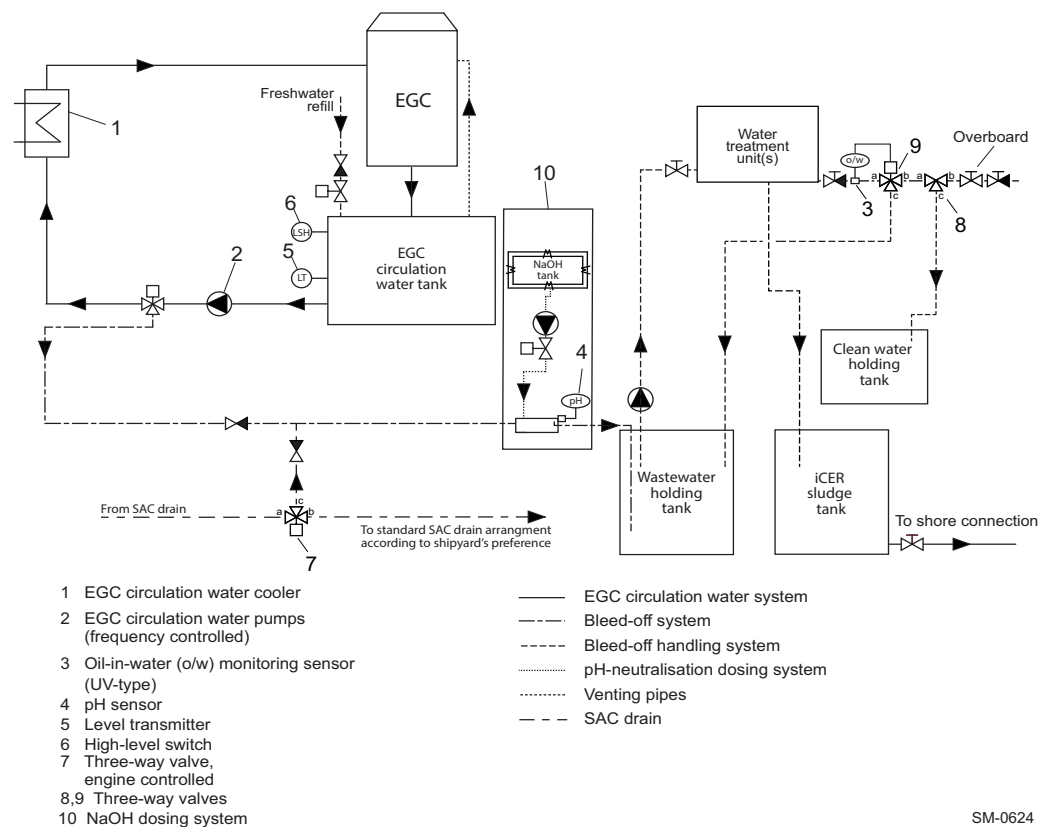

Figure 4-5 The iCER drainage system for installations which run the iCER system exclusively in gas mode

For this arrangement, when the tank filling level value provided by the level transmitter exceeds the maximum value as defined in the software, then the EGC circulation water pump will pump out water from the EGC circulation water tank until a specific level has been reached. If required, the water removal can also be manually activated due to water contamination or other reasons. For safety purposes, in case the automatic drainage system fails, a high-level switch is installed in the EGC circulation water tank to initiate a shutdown of the iCER operation. The engine then trips to operation in diesel mode.

During iCER operation, the bleed-off water and the SAC drain water are directed through a pH-neutralisation dosing unit before entering the wastewater holding tank (see the subsection [NaOH dosing](#), § 4-12). This ensures that the water in the wastewater holding tank maintains a proper pH value (e.g. above pH 6). When the iCER system is de-activated, the SAC drain water is automatically directed to the standard SAC drain arrangement according to the shipyard's preference.

The water in the wastewater holding tank is directed to the water treatment unit. After treatment, if the oil-in-water (o/w) content exceeds 15 ppm, the water is directed back to the wastewater holding tank by activating the valve 9 (a-c). Otherwise, if the oil-in-water content does not exceed 15 ppm and the vessel is operating outside an area of restricted overboard discharge, the water can then be directly pumped overboard by activating the valve 8 (a-b). If the vessel is operating in an area of restricted discharge, the clean water is stored in the clean water holding tank by activating the valve 8 (a-c). Depending on the type of water treatment unit, coagulant and flocculant dosing may be required. For further details, please refer to the supplier of the water treatment unit.

NOTE

According to resolution MEPC 307(73), a direct overboard discharge is possible if the oil-in-water content is below 15 ppm.

Unified arrangements of the iCER drainage system, valid for all iCER operating mode options

The initial design variant for iCER projects, valid for all iCER operating mode options, provides water treatment for the EGC circulation water, the bleed-off water and the SAC drain water. During iCER operation, the water treatment is carried out by means of a water treatment unit.

Figure 4-6 provides a sketch of this unified arrangement of the iCER drainage system.

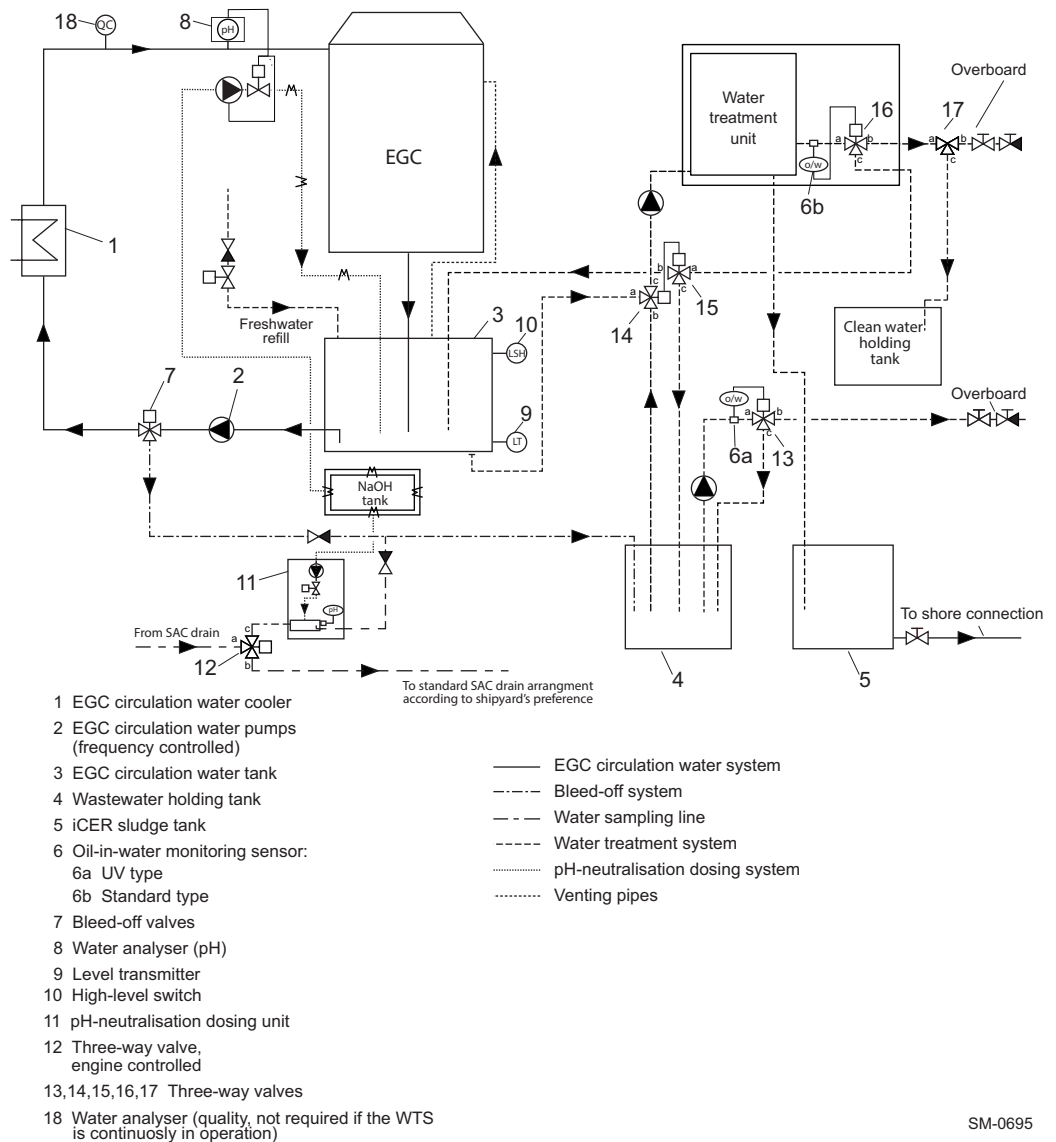

Figure 4-6 The iCER drainage system valid for all iCER operating mode options

During iCER operation, soot can be found in the EGC circulation water. This must be removed by a water treatment unit. The design of the water treatment unit may vary depending on the supplier. In addition, as the ultra-low sulphur MGO with a maximum content of 0.10% m/m sulphur is not sulphur-free, neutralisation of the resulting acids is required. For this purpose, a caustic soda (NaOH) dosing system is required for the EGC circulation water. The dosage amount is controlled by the water analyser which measures the acidity of the effluents requiring pH adjustment.

NOTE	The water treatment system must ensure a proper pH value (e.g. above pH 6) at the different positions of the iCER drainage system. The water treatment system must be designed in such a way that a maximum solids content of 150 mg/l is maintained in the EGC circulation water.
-------------	--

Chemical consumption during iCER operation

Table 4-2 Chemicals required for treatment of the EGC circulation water

Coagulant consumption (if applicable):	According to supplier
Flocculant consumption (if applicable):	According to supplier
Caustic soda (50% m/m NaOH) consumption in gas mode:	0.06 l/MWh
Caustic soda (50% m/m NaOH) consumption in diesel Tier III mode:	0.2 l/MWh

During iCER operation, the bleed-off water and the SAC drain water are stored in the wastewater holding tank. The SAC drain water must be directed through a pH-neutralisation dosing unit (see the subsection [NaOH dosing](#)) before being drained to the wastewater holding tank. This ensures that the water in the wastewater holding tank maintains a proper pH value (e.g. above pH 6). When the iCER system is de-activated, the SAC drain water is automatically directed to the standard SAC drain arrangement.

From the wastewater holding tank, the wastewater is then directed to the water treatment unit by activating valve 14 (b-c). After the treatment, if the oil-in-water (o/w) content of the water exceeds 15 ppm, the water is directed back to the wastewater holding tank by activating valves 16 (a-c) and 15 (a-c). Otherwise, if the oil-in-water content does not exceed 15 ppm and the vessel is operating outside an area of restricted overboard discharge, the water can then be directly pumped overboard by activating valves 16 (a-b), 17 (a-b). If the vessel is operating in an area of restricted discharge, the clean water is stored in the clean water holding tank by activating valve 17 (a-c). For this design, a fast discharge option of the wastewater is also possible. For further details, please refer to the supplier of the water treatment unit.

Coagulant and flocculant dosing

Depending on the design of the water treatment unit, coagulant and flocculant dosing may be required. The water treatment unit controls the dosing and removes the particles accumulated by the treatment as well as other hydrocarbons. The coagulant and flocculant are typically stored in small units and do not require any structural tank.

NaOH dosing

Sodium hydroxide (NaOH), also known as caustic soda, is added to the EGC circulation water to neutralise the acidity. The alkali nature of NaOH counteracts the acid build-up from washing of the exhaust gas.

The water acidity is measured by sensor. This sensor is connected to a monitoring and control unit, which controls the NaOH dosing pump and adds NaOH to the EGC circulation water. NaOH dosing is also considered for the SAC drain water.

The NaOH dosing system is designed for an aqueous solution consisting of a maximum concentration of 50% m/m NaOH. Alternatively, the design can also be made for solutions with lower concentrations, typically for 25% or 30% m/m NaOH. It is necessary to consider the required storage and handling temperature of the NaOH solution. Depending on the concentration, the piping system of the NaOH dosing unit and storage tank must be heated (e.g. trace heating) and insulated. For solutions of 50% m/m NaOH, a storage and handling temperature in the range of 16 °C to 45 °C is required. For solutions of maximum 30% m/m NaOH, storage at normal engine room ambient temperature is sufficient. Due to the corrosive and dangerous nature of NaOH, extreme caution is required. It is recommended that a safety shower is located close to the NaOH dosing unit and storage tank. In addition, the material safety data sheet must be consulted for the installation of the NaOH dosing unit and storage tank.

Forced bleed-off A manual bleed-off function is available. Depending on the available condensate water, the EGC circulation water tank can also be re-filled by freshwater.

Sludge amount When the water treatment system is active, sludge is produced. The properties of this sludge are different from the sludge defined in section 4.9.1, § 4-106. In principle, it is oily water with soot. According to resolution MEPC 307(73), the sludge from the water treatment system must be collected in a dedicated iCER sludge tank and must be disposed of ashore. The amount of sludge produced is dependent on the selected water treatment unit and it must be considered for sizing of the iCER sludge tank. For further details, please refer to the supplier of the water treatment unit.

A new variant of the iCER drainage system

Since April 2022, a new variant of the iCER drainage system has been available for all iCER operating mode options.

Figure 4-7 provides a sketch of the new unified iCER drainage system.

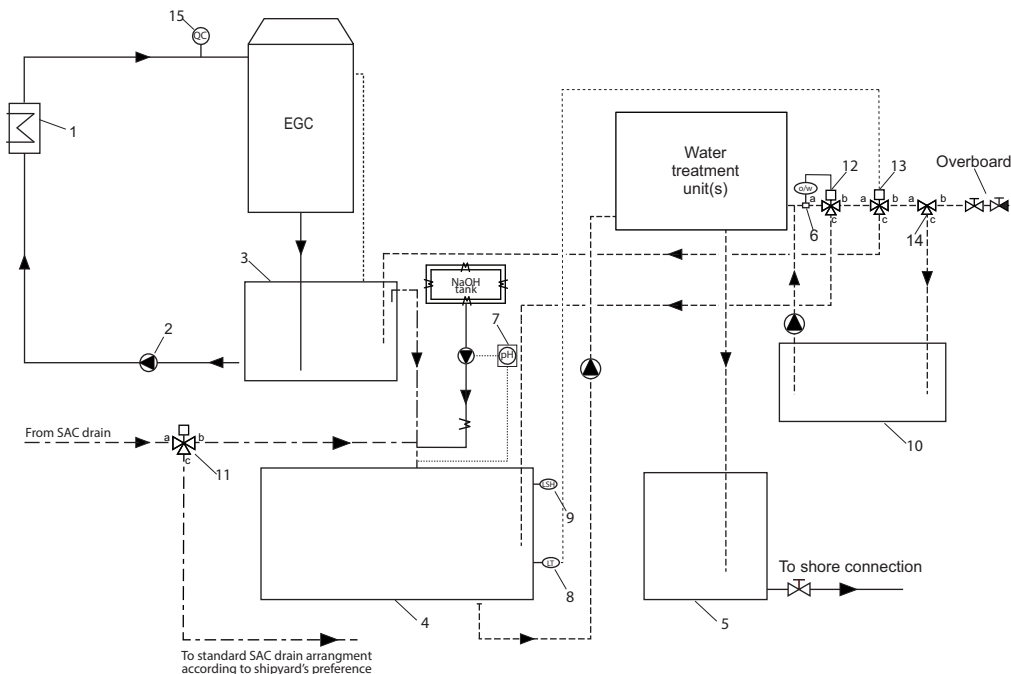

- | | |
|--|---|
| <ul style="list-style-type: none"> 1 EGC circulation water cooler 2 EGC circulation water pumps (frequency controlled) 3 EGC circulation water tank 4 Wastewater holding tank 5 iCER sludge tank 6 Oil-in-water (o/w) monitoring sensor, standard type 7 Water analyser (pH) 8 Level transmitter 9 High-level switch 10 Clean water holding tank 11 Engine-mounted and controlled three-way valve 12,13,14 Three-way valves 15 Water analyser (quality, not required if the WTS is continuously in operation) | <ul style="list-style-type: none"> — EGC circulation water system - - - Bleed-off system - - - - Water treatment system pH-neutralisation dosing system Venting pipes - . - . SAC drain |
|--|---|

SM-0810

Figure 4-7 A new variant of the unified iCER drainage system

During iCER operation, the EGC circulation water is continuously overflowing to the wastewater holding tank, while the SAC drain water is also collected in the same tank. When the iCER system is de-activated, the SAC drain water is automatically directed to the standard SAC drain arrangement.

During iCER operation, the bleed-off water and the SAC drain water are neutralised by means of a pH-neutralisation dosing unit (see the subsection [NaOH dosing](#), [4-12](#)). The NaOH solution is dosed directly in the connection pipe before entering the wastewater holding tank. This ensures that the water in the wastewater holding tank maintains a proper pH value (e.g. above pH 6). Alternatively, the NaOH solution can also be dosed directly into the wastewater holding tank. In this case, the material of the wastewater holding tank must be selected according to the low pH value (e.g. between pH 3 and 4).

The wastewater is then directed to the water treatment unit, which can handle a certain volume. After the treatment, if the oil-in-water (o/w) content of the water exceeds 15 ppm, the water is directed back to the wastewater holding tank by activating valves 12 (a-b) and 13 (a-c). Otherwise, if the oil-in-water content does not exceed 15 ppm and the vessel is operating outside an area of restricted overboard discharge the water can then be directly pumped overboard by activating valves 12 (a-b), 13 (a-b) and 14 (a-b). If the vessel is operating in an area of restricted discharge, the clean water is stored in the clean water holding tank by activating valve 14 (a-c).

Clean water from the water treatment unit is constantly re-circulated back to the EGC circulation water tank. The amount of clean water recirculated is based on the filling level of the wastewater holding tank (measured by the level transmitter and adjusted as defined in the software). This circulation is controlled by valve 12 (a-c). Dilution of the EGC circulation water with clean water results in indirect pH adjustment of the EGC circulation water. For further details, please refer to the supplier of the water treatment unit.

The unified iCER drainage system for twin-engine installations must consider two independent EGC circulation water systems and a common EGC circulation water treatment system (see [Figure 4-8](#), [4-16](#)). A common EGC circulation water tank can also be considered (see [Table 4-1](#), [4-2](#)).

The same principle can be applied to an alternative design of the iCER drainage system (see [Figure 4-5](#), [4-9](#) and [Figure 4-6](#), [4-11](#)).

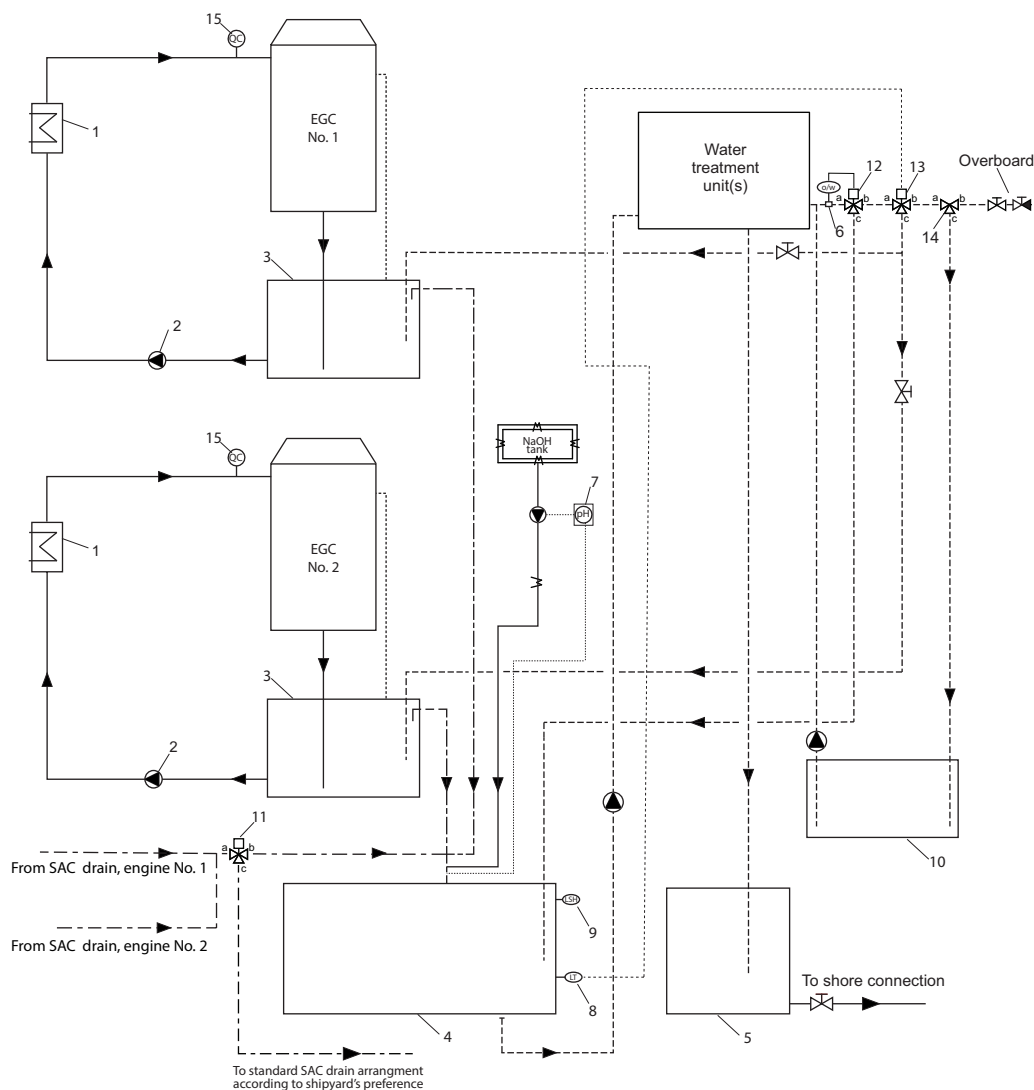

- | | |
|--|---|
| <ul style="list-style-type: none"> 1 EGC circulation water cooler 2 EGC circulation water pumps (frequency controlled) 3 EGC circulation water tank 4 Wastewater holding tank 5 iCER sludge tank 6 Oil-in-water (o/w) monitoring sensor, standard type 7 Water analyser (pH) 8 Level transmitter 9 High-level switch 10 Clean water holding tank 11 Engine-mounted and controlled three-way valve 12,13,14 Three-way valves 15 Water analyser (quality, not required if the WTS is continuously in operation) | <ul style="list-style-type: none"> — EGC circulation water system - - - Bleed-off system --- Water treatment system pH-neutralisation dosing system Venting pipes - - - SAC drain |
|--|---|

SM-0818

Figure 4-8 The unified iCER drainage system for twin-engine installations

If the capacity of one water treatment unit is insufficient, then either multiple water treatment units can be operated in parallel, or one dedicated water treatment system can be installed to clean the EGC circulation water while another is installed to clean the excess water for discharge overboard (see [Figure 4-9](#), [4-17](#) and [Figure 4-10](#), [4-18](#)).

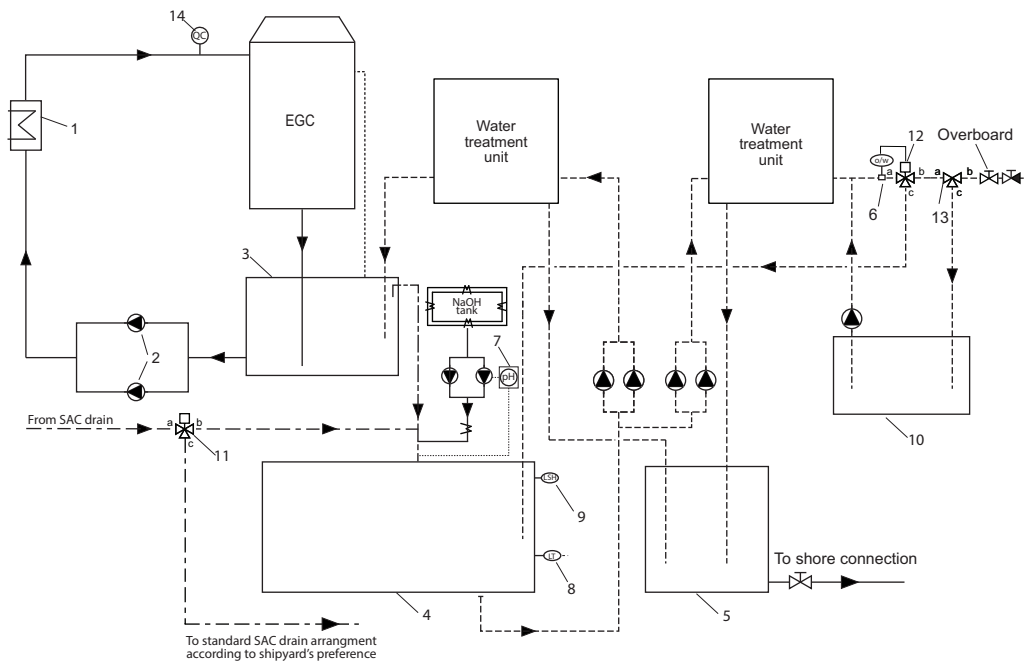

- | | |
|---|---|
| <ul style="list-style-type: none"> 1 EGC circulation water cooler 2 EGC circulation water pumps (frequency controlled) 3 EGC circulation water tank 4 Wastewater holding tank 5 iCER sludge tank 6 Oil-in-water (o/w) monitoring sensor, standard type 7 Water analyser (pH) 8 Level transmitter 9 High-level switch 10 Clean water holding tank 11 Engine-mounted and controlled three-way valve 12,13 Three-way valves 14 Water analyser (quality, not required if the WTS is continuously in operation) | <ul style="list-style-type: none"> — EGC circulation water system - - - Bleed-off system --- Water treatment system pH-neutralisation dosing system Venting pipes - - - SAC drain |
|---|---|

SM-0819

Figure 4-9 The unified iCER drainage system with a dedicated water treatment system for EGC circulation water refreshing and for bleed-off water cleaning

Figure 4-9 provides a schematic of a solution which refreshes the EGC circulation water tank with water from the wastewater holding tank. This tank includes a mixture of the SAC drain water and bleed-off water, which ensures that the EGC circulation water tank will always be filled with sufficient clean water.

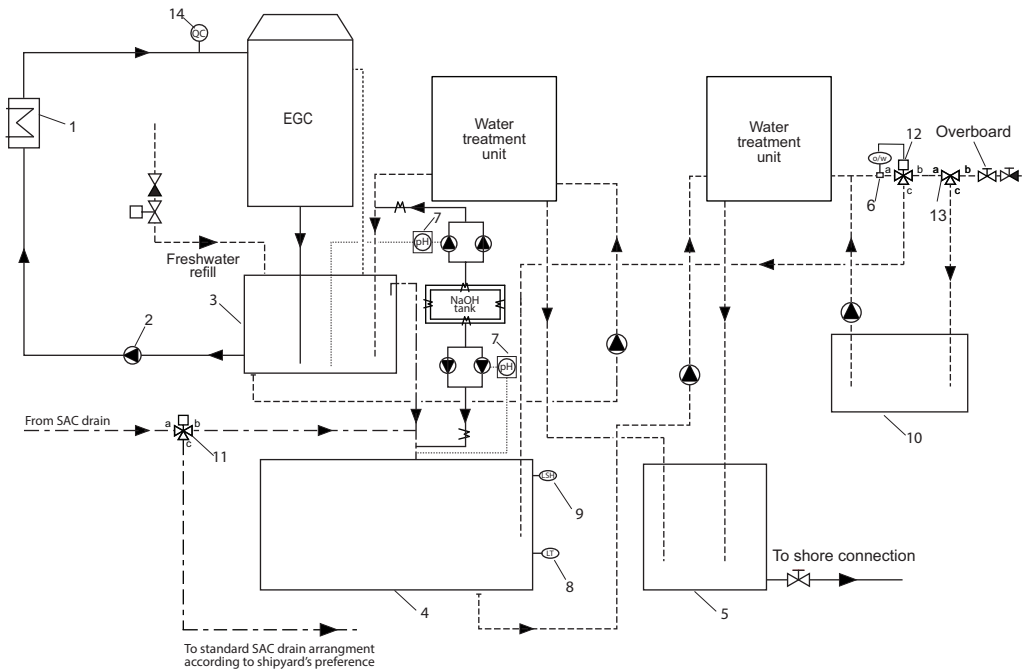

- | | |
|---|---|
| <ul style="list-style-type: none"> 1 EGC circulation water cooler 2 EGC circulation water pumps (frequency controlled) 3 EGC circulation water tank 4 Wastewater holding tank 5 iCER sludge tank 6 Oil-in-water (o/w) monitoring sensor, standard type 7 Water analyser (pH) 8 Level transmitter 9 High-level switch 10 Clean water holding tank 11 Engine-mounted and controlled three-way valve 12,13 Three-way valves 14 Water analyser (quality, not required if the WTS is continuously in operation) | <ul style="list-style-type: none"> — EGC circulation water system - - - Bleed-off system - - - - Water treatment system pH-neutralisation dosing system - · - · - Venting pipes - - - - SAC drain |
|---|---|

SM-0862

Figure 4-10 The unified iCER drainage system with a dedicated water treatment system for EGC circulation water cleaning and for bleed-off water cleaning

Figure 4-10 provides a schematic of a solution which ensures independent water treatment for the EGC circulation water. During tropical or close to tropical iCER diesel Tier III mode operation and within a specific CMCR engine power range, freshwater may be required to refill the EGC circulation water tank. The project-specific freshwater values attained by the *GTD* and the specific water loss of the selected water treatment system provide the total freshwater consumption.



The latest version of the **Marine Installation Drawing Set** relevant for the drainage collection from the iCER system can be found in the MIDS cooling water system drawings (DG 9721), which is provided on the WinGD webpage under the following link:

[MIDS](#)

The MIDS provides a guide for sizing the clean water holding tank. Project-specific data sets for bleed-off water and SAC drain water amounts are available for different ambient conditions in the [GTD](#).

NOTE

The operating time in areas of restricted water discharge (by environmental regulations) must be considered for sizing of the wastewater holding tank.

The hourly drain amount depends on the engine operating profile (i.e. engine power and ambient conditions) and is provided in the [GTD](#).

4.2.4 The SAC wetting system

Since particulate matter and oil cannot be fully removed from exhaust gas as it passes from the EGC through the SAC, part of it tends to accumulate on the SAC, leading to fouling over time. Deposits reduce the SAC thermal efficiency and increase the pressure drop over the SAC, potentially affecting engine operation. In principle, a cleaner SAC leads to lower engine fuel consumption. To help prevent fouling, a wetting process must be implemented.

As shown in Figure 4-11, treated water from the clean water holding tank is directed to the upper part of the SAC and sprayed to keep the active cooling surfaces wet. This significantly reduces accumulation of particulate matter, ash, and oil on the active cooling surfaces of the SAC. For projects without a clean water holding tank, a dedicated SAC wetting buffer tank is required as shown in Figure 4-12.

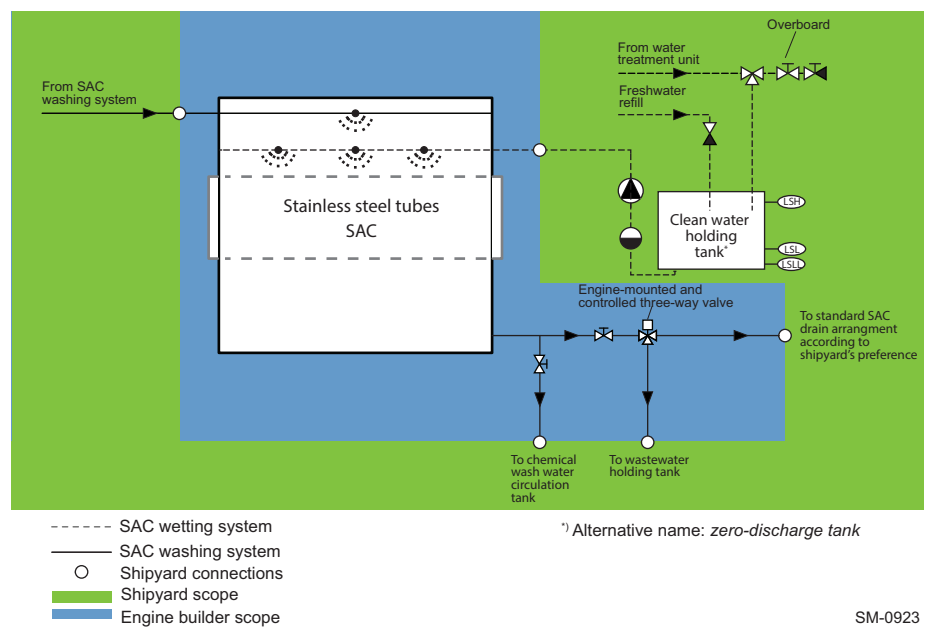

Figure 4-11 The SAC wetting system with the clean water holding tank arrangement

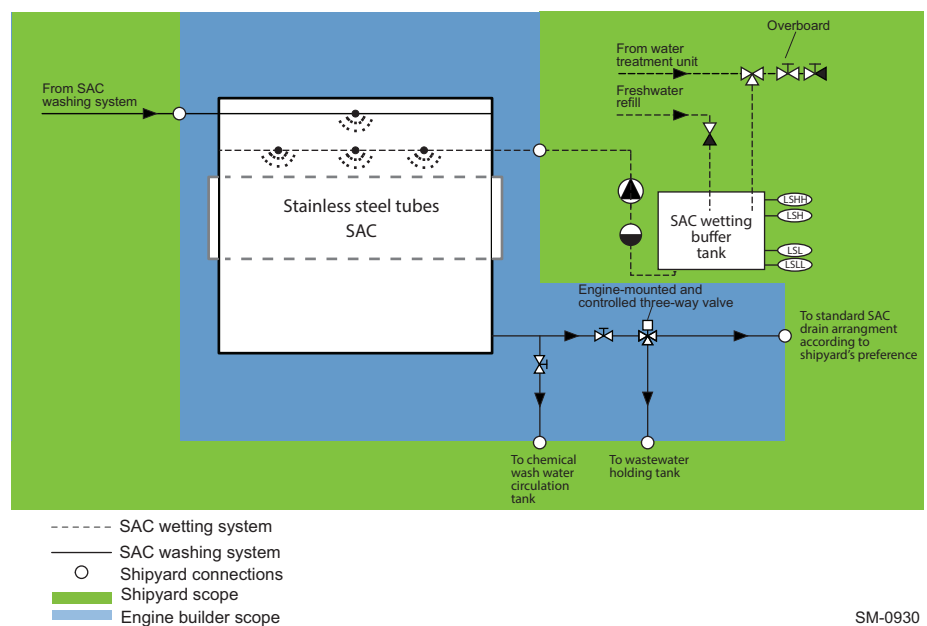

Figure 4-12 The SAC wetting system with the SAC wetting buffer tank arrangement

Functional description

The SAC wetting system is controlled by an SAC wetting control unit. The ECS communicates with this control unit, commanding when wetting starts and stops.

For systems with the clean water holding tank arrangement, the water from the WTS is directed to the clean water holding tank by means of a three-way valve. In case the minimum tank level is reached, the three-way valve directs the water to the clean water holding tank. Otherwise, overboard discharge depends on the ship operating area.

For systems with an SAC wetting buffer tank, an additional Level Switch High-High (LSHH) sensor is installed on the buffer tank (see [Figure 4-12](#), [Figure 4-20](#)). This sensor is required to control the three-way valve to keep the tank full while the WTS is running.

From the clean water holding tank or the SAC wetting buffer tank, the water is sprayed onto the active cooling surfaces of the SAC by means of a wetting water pump. In case of a Level Switch Low-Low (LSLL) detection, an emergency stop is initiated to prevent the pump from running dry.

In addition to the SAC wetting system, an optional washing system as described in section [4.9.5 The SAC washing system](#), [Figure 4-113](#) can be applied to ensure thorough cleaning during engine standstill.



For further details on the installation of the iCER system, including the SAC buffer tank size and the wetting pump layout calculations, see the [iCER Installation Guideline](#)

4.2.5 The iCER exhaust gas system

For the general exhaust gas system description, refer to section 4.10, 4-114.

The iCER is designed to recirculate approximately 50% of the exhaust gas during gas mode operation and a reduced amount during diesel Tier III mode operation. The recirculation is through a low-pressure path, allowing for the full use of the turbocharger's capacity.

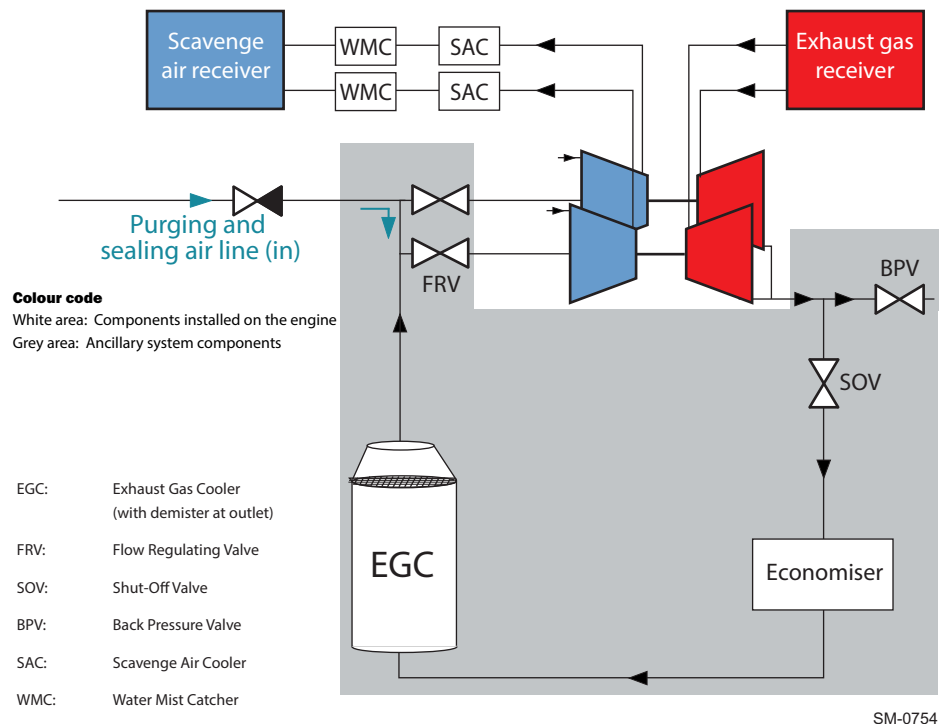

Figure 4-13 The iCER exhaust gas system with the exhaust gas return pipe routed to the turbocharger connection from below

Pressure and control valves

The iCER exhaust gas system connects to both sides of the turbocharger and it controls the exhaust gas recirculation flow rate with a series of valves. During normal engine operation, the Back Pressure Valve (BPV) controls the amount of exhaust gas that is recirculated to the engine. The Shut-Off Valve (SOV) is either fully open or closed, depending on whether the iCER system is active or not. The Flow Regulating Valve (FRV) can be used to support the control of the flow rate in the iCER system, especially when operating in diesel Tier III mode.

Purging and sealing air line

A purging and sealing air line is connected to the iCER exhaust gas system. To prevent backflow of exhaust gas to the air supply line, a non-return valve must be installed. A purging and sealing air blower is required and must be designed with a 0.15 bar(g) pressure head. The flow rate of the blower is defined by either the purging air demand or the sealing air demand, depending on which is higher. The purging air demand is defined as 4.5 times the volume of the iCER exhaust gas recirculation system per hour. The sealing air demand is defined by the leakage rate of the FRV and the SOV at a differential pressure of 0.15 bar(g). To limit the sealing air amount, a higher leakage class can be selected.

During purging, the purging and sealing air blower provides continuous air. Purging air pushes the residual gas through the open SOV to the funnel. The sealing air pressure must be maintained between 0.10 and 0.15 bar (g).

For all projects contracted prior to April 2022, an engine-mounted purging and sealing air blower is provided. For any other iCER system installations, such a blower must be installed on the ship side. In both cases, the purging and sealing air system is controlled by the engine control system.

Protection against water droplets

The EGC has an integrated demister before its outlet. This demister removes water droplets of a critical size carried by the exhaust gas.

After passing the EGC, the humid recirculating exhaust gas may condense on the pipe wall and consequently, may be carrying water droplets (see section 4.2.2 [The EGC circulation water system](#), ¶ 4-6). For all iCER system installations, the exhaust gas return pipe is routed to the turbocharger connection from below, and there is no WMC installed. This prevents condensate water from being carried over to the turbochargers. Condensate water drains must be arranged at the lowest point of the horizontal return manifold pipe. Different vessel trim conditions must be considered.

Thermal insulation

As required for exhaust gas piping, the high-temperature pipes must be thermally insulated upstream of the EGC. The pipes also require the same thermal insulation downstream of the EGC, as this will reduce condensation within the system.

Piping material

The exhaust gas piping, downstream of the additional economiser and the EGC, must be made of stainless steel (or alternative corrosion-resistant material).



For further information about system design and pressure requirements, see the drawings relevant for the exhaust gas system (DG 9726) which are provided on the WinGD webpage under the following link:

[MIDS](#)



Exhaust gas pressure and temperature values are available from WinGD's engine layout application [GTD](#).

Pressure losses

The exhaust gas system design must consider many components. The maximum pressure loss over the cooler and the additional economiser is 150 mmWC.

Pressure losses and thermal expansion must be considered across the entire iCER system and will affect the design, selection and location of bellows within the system.

Structural support

The piping of the exhaust gas system must be structurally supported to withstand the mass and to minimise vibrations across the system. It is suggested that this is achieved by supports which are connected to the ship hull or otherwise.

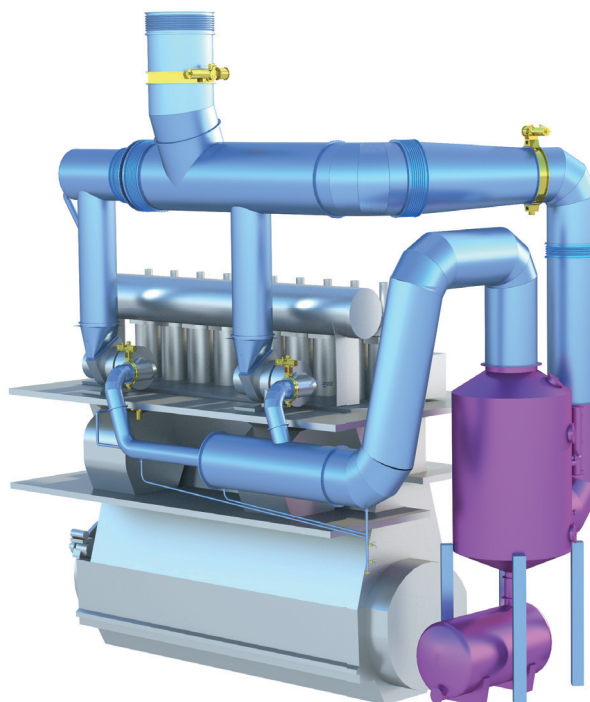

SM-0856

Figure 4-14 Example of an exhaust gas piping arrangement

For further details on the installation of the iCER system, including initial system cleaning before start-up, please see the *iCER Installation Guideline*

4.2.6 Heat recovery (economiser)

A main economiser can be installed at different positions depending on the selected routing concept. Optionally, an additional economiser can be installed in the exhaust gas recirculation line.

Different routing concepts

Two different routing concepts are available for the iCER exhaust gas system:

- Short route
- Long route, different variants

Short route arrangement

The branch connection to the iCER system is located directly after the turbo-charger outlet. Consequently, the recirculated exhaust gas bypasses the main economiser. To compensate for the resulting lower steam production, an additional economiser can be installed in the exhaust gas recirculation line. Usually, this additional economiser has no steam drum integrated, for compactness and cost purposes, and must therefore be connected to the main economiser.

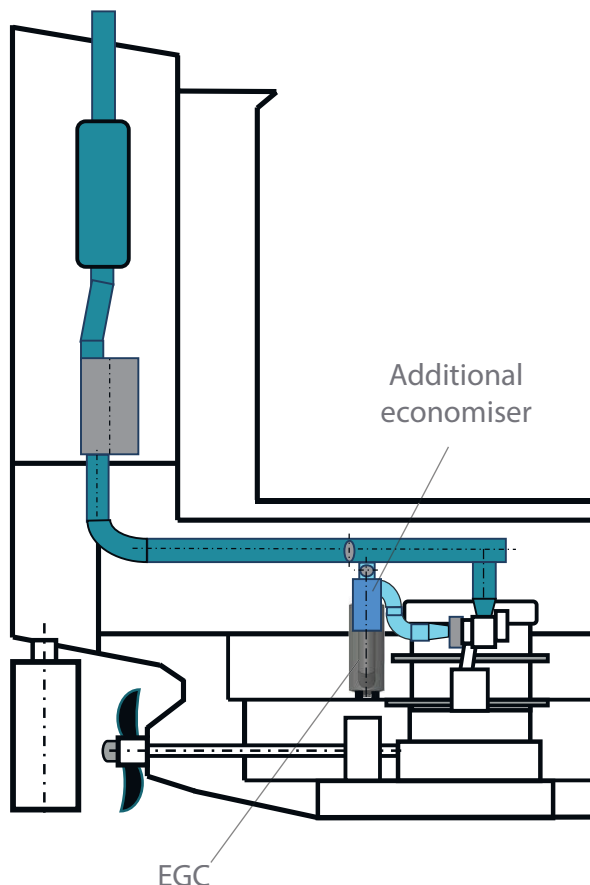

SM-0826

Figure 4-15 The short route arrangement

Long route arrangement

The full exhaust gas flow passes through the main economiser. The iCER recirculation branch is connected downstream from the main economiser outlet. The exhaust gas cooler can be placed close to the boiler, close to the turbocharger inlet, or anywhere in between these two positions. The long route arrangement provides the advantage of ensuring that the maximum steam production is available without the requirement of any additional economiser. However, the longer piping provides the challenge of keeping the maximum allowed exhaust gas back pressure in the iCER system within the specified range.

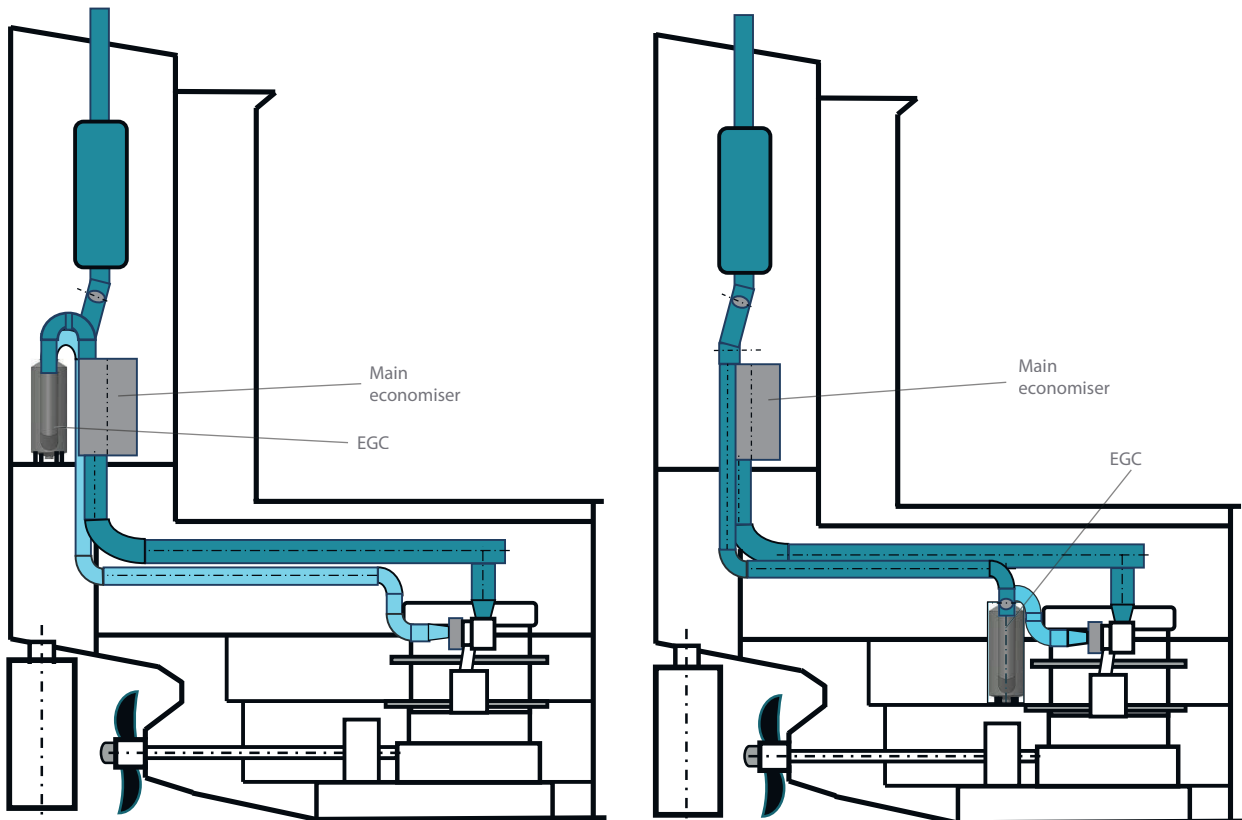

SM-0827

Figure 4-16 The long route arrangement

Special long route arrangement

The cases where it is not possible to fulfil the maximum back pressure limit due to the long route, WinGD should be contacted for project-specific support. Project-specific solutions, including project-specific performance data, can be made available.

Additional economiser (optional)

An additional economiser can be placed upstream of the EGC, therefore ensuring the necessary steam production. By adding this additional economiser, the thermal energy from the exhaust gas can be utilised. The economiser can be installed directly to the steam line.

The on-board steam requirement must be calculated carefully before considering this additional economiser, as less steam production power is generally required during gas operation.

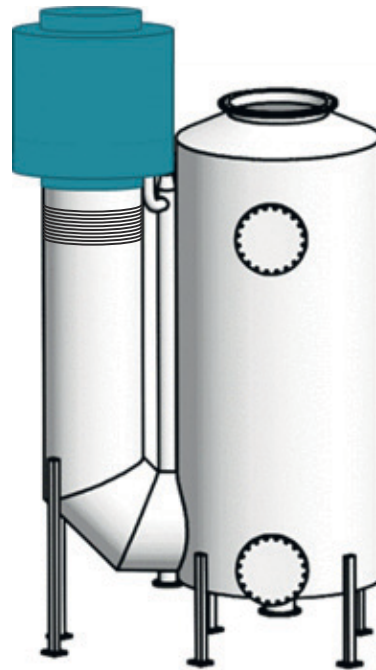

SM-0579

Figure 4-17 Arrangement of the additional economiser (Source: Alfa Laval)

To keep this additional economiser compact, a direct connection to the main economiser is required. For this reason, there is no need to include its own water drum.

If the iCER is active in gas mode, the exhaust gas is essentially considered to be sulphur free. As a result, there is no restriction on the additional and main economiser in reducing the exhaust gas below 160-170°C. Even in diesel Tier III mode operation, the lower exhaust gas temperature may be selected as the sulphur content in the fuel is limited to 0.10% m/m sulphur.

The exhaust gas piping, downstream of the additional economiser and the EGC, must be made of stainless steel (or alternative corrosion-resistant material).

4.3 Cooling water system



The latest version of the **Marine Installation Drawing Set** relevant for the cooling water system (DG 9721) is provided on the WinGD webpage under the following link:

[MIDS](#)

Freshwater cooling system

The main engine high-temperature (HT) and low-temperature (LT) cooling circuits use freshwater as their cooling medium. As such, the HT and LT circuits are integrated in the ship's central freshwater cooling system.

Advantage of freshwater over seawater

Freshwater cooling systems reduce the amount of seawater pipework and its associated problems like scaling and corrosion. Freshwater provides for more efficient cooling as it allows a higher heat load than seawater, i.e. freshwater can be heated up to a higher temperature level and, along with a lower flow rate, allows the same cooling effect to be obtained. Thereby the overall running costs are reduced.

Separate HT circuit with own cooler

The central freshwater cooling system for the WinGD X82DF-2.0 runs with single-stage scavenge air cooler and separate HT circuit. The HT circuit must be completely separate from the LT circuit. A dedicated HT water cooler is applied for heat exchange between HT and LT circuit without flow medium mixing. [Figure 4-18](#) shows the general installation principle.

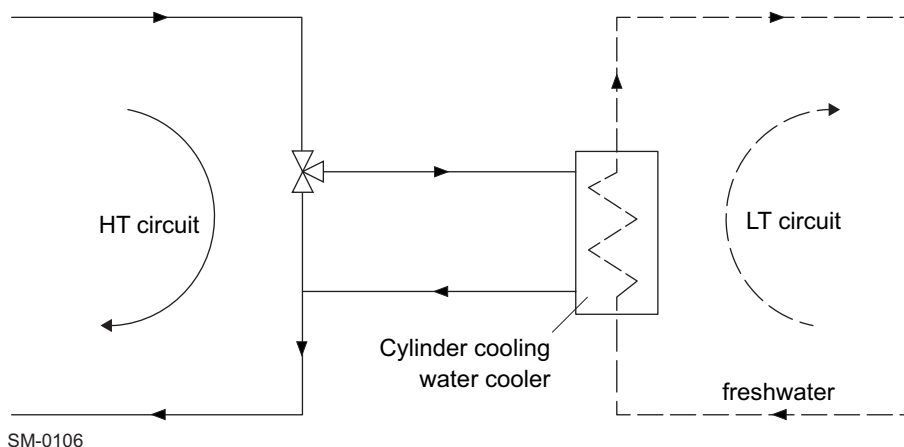

Figure 4-18 Separate HT cooling water circuit

NOTE

For detailed cooling design and the necessary data for this arrangement please refer to MIDS and GTD respectively.

4.3.1 Low-temperature circuit

The LT cooling water circuit for the main engine provides cooling for the SAC, the LO cooler and the MDO/MGO cooler.

Setting of automatic temperature control valve for cooling water

For the main engine SAC, the automatic temperature control valve must be set to 25°C (set-point). When seawater temperatures are higher than 21°C — assuming a maximum seawater temperature of 32°C — the cooling water temperature for the SAC may increase to maximum 36°C. It is recommended to keep the temperature of the LT circuit as low as possible.

NOTE

The automatic temperature control valve of the SAC must be set to 25°C (see [Arrangement 1](#), [4-30](#)). If ancillary machinery requires a different temperature set-point, then a separate cooling water loop must be installed as shown in [Arrangement 2](#), [4-30](#) and [Arrangement 3](#), [4-31](#).

Warm seawater conditions may result in higher BSFC and respectively BSEC than in ISO standard design condition.

Arrangements of LT cooling water circuit

Consequently, depending on the ancillary equipment and the temperature set-point selection, the LT circuit can be typically installed in the following arrangements:

- Arrangement 1 — Single set-point temperature 25°C (see [Figure 4-19](#), [4-30](#))
- Arrangement 2 — Dual set-point temperatures (see [Figure 4-20](#), [4-30](#))
- Arrangement 3 — Separate SAC cooling circuit (see [Figure 4-21](#), [4-31](#))

Arrangement 1

To maintain the required SAC inlet temperature, the automatic temperature control valve of the central freshwater cooling system is set to 25°C (WinGD specification). In this arrangement, the ancillary plant and other cooler temperatures are controlled and maintained by this single temperature set-point.

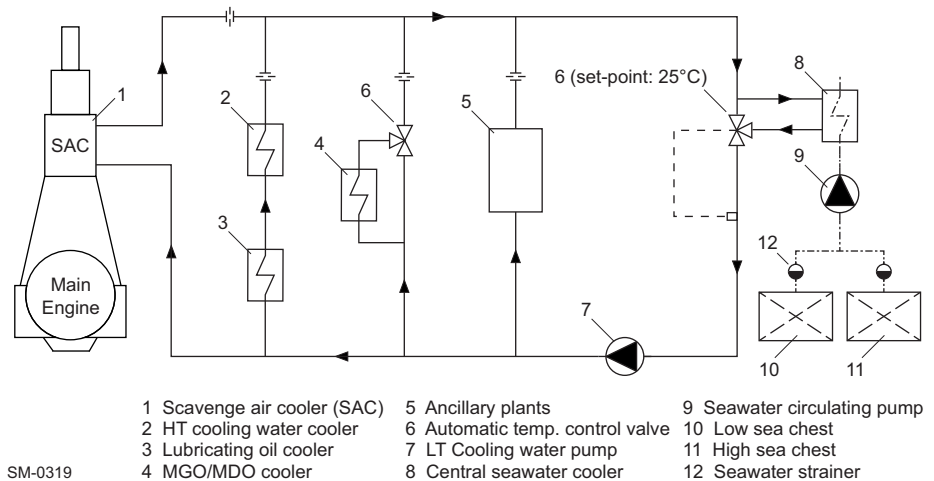

Figure 4-19 LT cooling water circuit — Single set-point temperature

Arrangement 2

The central freshwater cooling system is separated into different cooling streams to provide different temperature set-points for the ME SAC and ancillary equipment. To maintain the required SAC inlet temperature, the automatic temperature control valve of the central freshwater cooling system must be set to 25°C (WinGD specification). The ancillary plant temperature control valve can be set differently as the specific project requires, for example between 25 and 36°C.

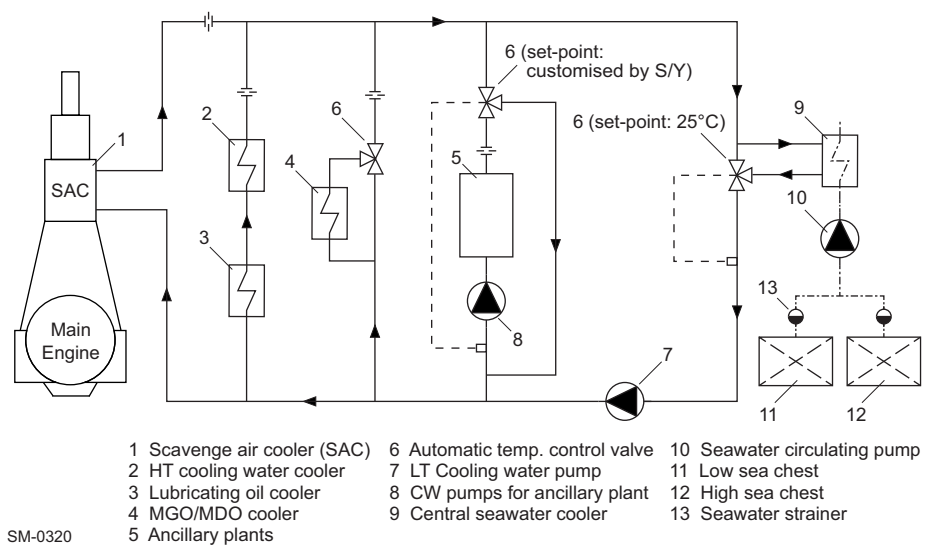

Figure 4-20 LT cooling water circuit — Dual set-point temperatures

Arrangement 3

The central freshwater cooling system is separated into two dedicated cooling circuits to better manage the varying temperature set-points. This includes:

- **Circuit 1:**
The ME SAC is cooled with freshwater with a temperature set-point of 25°C (WinGD specification). With this arrangement, only the ME SAC requires maximum design seawater flow for cooling.
- **Circuit 2:**
All other ME and ancillary plant coolers are cooled with freshwater with a set-point customised by the shipyard or ship designer.

Figure 4-21 is a proposal only and the seawater pump and other equipment layout might be different. As such, the shipyard is free to design their own seawater system. However, the set-point temperature for the ME SAC must be 25°C as per WinGD specifications.

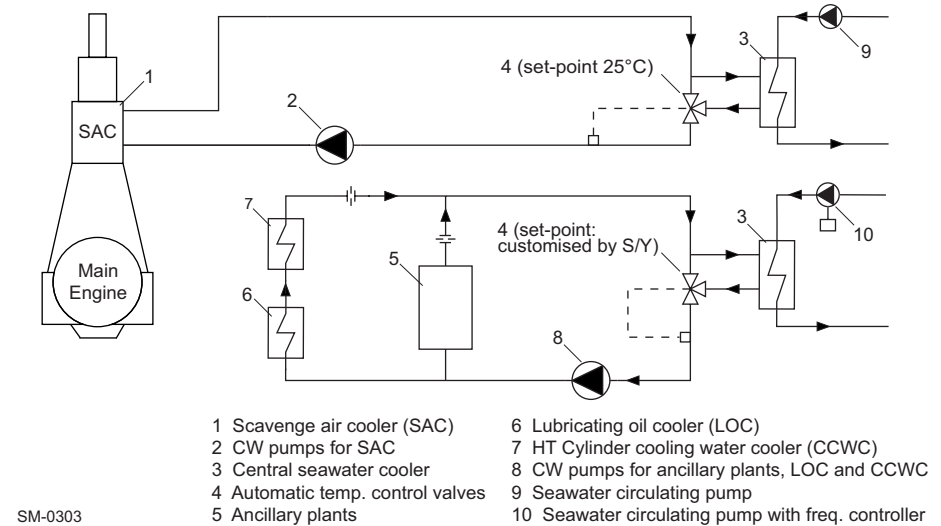

Figure 4-21 Separate SAC and LT cooling circuits

*Low-temperature circuit components***Seawater circulating pump**

The seawater circulating pump delivers seawater from the high and low sea chests to the central seawater cooler.

Pump type	Centrifugal
Capacity	According to <i>GTD</i> : The seawater flow capacity covers the need of the engine only and is to be within a tolerance of 0 to + 10% of the GTD value
Delivery pressure	Determined by system layout
Working temperature	According to ship specification

Seawater strainer

Simplex or duplex strainers to be fitted at each sea chest and arranged to enable manual cleaning without interrupting the flow. The strainer mesh size (max. 6mm) must prevent the passage of large particles and debris that could damage the pumps and impair the heat transfer across the coolers.

Central seawater cooler

Cooler type	Plate or tubular
Cooling medium	Seawater
Cooled medium	Freshwater
Design criterion	Keeping max. 36 °C LT while seawater temp. is 32 °C
Margin for fouling	10-15% to be added
Heat dissipation	Refer to <i>GTD</i>
Freshwater flow	
Seawater flow	
Temperatures	

Automatic temperature control valve

As stated above, the automatic temperature control valve for the cooling water to the SAC must be set to 25°C (WinGD specification). Temperature control of other ancillary plant is to be determined by the shipyard.

Valve type	Electrically or electro-pneumatically actuated three-way type (butterfly valves are not adequate) having a linear characteristic
Design pressure	5 bar
Test pressure	Refer to specification laid down by classification society
Press. drop across valve	Max. 0.5 bar
Controller	Proportional plus integral (PI)
Temperature sensor	According to control valve manufacturer's specification; fitted in engine outlet pipe

Freshwater pumps

Pump type	Centrifugal
Capacity	According to <i>GTD</i> : The freshwater flow capacity covers the need of the engine only and is to be within a tolerance of 0 to +10% of the GTD value
Delivery head	The final delivery head is determined by the layout of the system and must ensure that the inlet pressure to the scavenge air coolers is within the range of summarised data
Working temperature	According to ship specification

4.3.2 High-temperature circuit

Based on experience and technological development, the HT cooling circuit has been simplified. This consists of a single inlet for the cooling water, which flows through the cylinder liner and cover in sequence. The schematic drawing below (Figure 4-22, 4-34) shows the basic cooling water circuit arrangement.

Air separator

An air separator is designed as an engine component and arranged upstream from the engine HT cooling water outlet connection. The air separator separates air from water and vents the air out. Removal of air from the cooling water is essential to maintain an optimal cooling effect of the engine cylinder liner. Due to the gas safety requirement for the X-DF engines, the ventilation pipe from the air separator must be led separately outside of the engine.

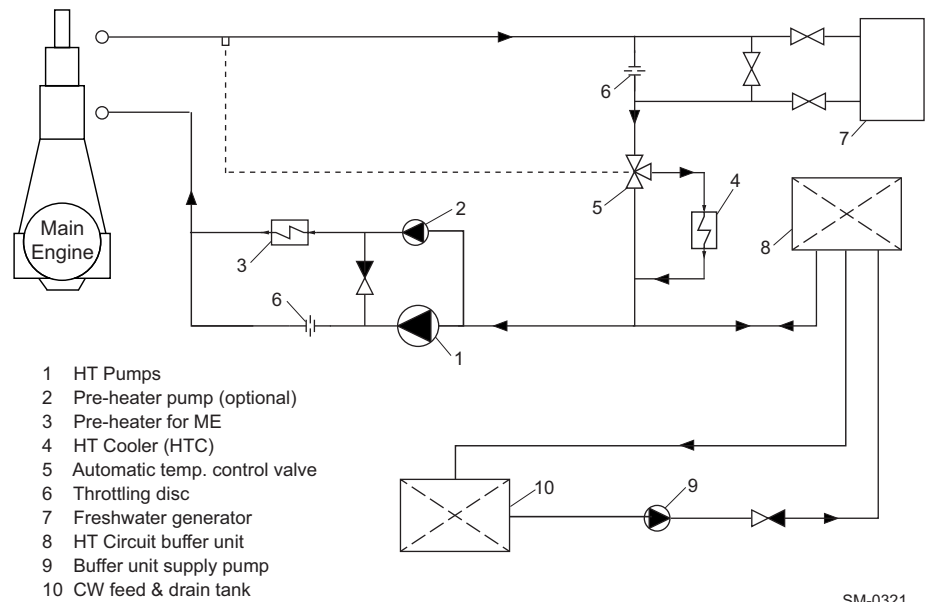

SM-0321

Figure 4-22 HT cooling water circuit

High-temperature circuit components

HT cooling water pump

Pump type	Centrifugal, preferably with a steep head curve ^{a)}
Pump capacity	According to <i>GTD</i> : The flow capacity is to be within a tolerance of - 10 to +20% of the GTD value
Delivery head ^{b)}	To be determined according to the total pressure losses (resistance) of the actual piping installation arrangement
Working temperature	95 °C

a) As a guide, the minimum advisable curve steepness can be defined as follows:
For a pressure increase from 100 to 107%, the pump capacity should not decrease by more than 10%.

b) The pump delivery head (p_p) will be:

$$p_p = p_{ei} - p_{st} + \Delta p + \frac{h}{10.2} \text{ [bar]}$$

where:

p_{ei} = pressure at engine inlet [bar]

p_{st} = static pressure* at pump inlet [bar]

Δp = pressure losses over piping between pump outlet and engine inlet [bar]

h = height difference between pump outlet and engine inlet [m]

* If an expansion tank is used, p_{st} equals the static pressure head from the change in height between expansion tank and pump inlet.

If a buffer unit is used, p_{st} equals the buffer unit pressure plus the pressure head from the change in height between buffer unit and pump inlet.

The pressure (p_{ei}) at engine inlet must be 4.0-5.0 bar(g).

To supply the cooling water system with the desired static pressure and compensate for the cooling water volume change during engine operation, WinGD proposes two possible solutions, namely installing either an expansion tank or a buffer unit.

Buffer unit

The installation of a buffer unit is an alternative solution. The buffer unit has the advantage of variable static pressure settings and location flexibility. However, it does require an additional water supply pump.

Main components and functionalities of the buffer unit:

- **Control air shut-off valve** (DN15), solenoid type, controlled by the signal from the Level Switch Low (LSL). This valve is normally open but to be shut off when the signal from the LSL is triggered and water feeding is started.
- **Control air pressure regulating valve** (DN15), with pressure reduction and air release function. This valve reduces the control air pressure to the desired buffer unit pressure. It enables air to be released to maintain the pressure when the buffer unit water volume is increasing (refill or water expansion). The pressure setting of the buffer unit is targeted to ensure that the cooling water pressure at the ME inlet fulfils the WinGD specification requirement.
- **Safety valve** (DN32), to be set at approximately 0.5bar above the buffer unit set pressure.
- **High-level switch and low-level switch:**
 - The LSL is set at approximately 35% of the total volume of the buffer unit. When the LSL is triggered, a signal is emitted simultaneously to the control air shut-off valve and the buffer unit supply pump to start.
 - The Level Switch High (LSH) is set at approximately 65% of the total volume of the buffer unit. When the LSH is triggered, a signal is emitted to stop the buffer unit supply pump.
 - The volume difference between the LSH and the LSL must not be less than 150 litres.
- **LAH and LAL**, high-level alarm and low-level alarm:
 - The LAH must be set at approximately 70% of the total volume of the buffer unit.
 - The LAL must be set at approximately 30% of the total volume of the buffer unit.

Buffer unit supply pump

The buffer unit supply pump compensates for losses in the CCW system. This pump is automatically controlled by the water level in the buffer unit. It is also advisable to monitor the running period of the supply pump. Monitoring of the pump running period will warn when the running period exceeds a pre-set value, indicating unusual water losses in the system. Spare parts for the supply pump must be available according to classification societies' requirements.

Pump type	Centrifugal or positive displacement
Capacity	0.5m ³ /h
Delivery head	4 bar (can be adjusted depending on project-specific design)

**Automatic
temperature control valve**

Valve type	Electrically or electro-pneumatically actuated three-way type (butterfly valves are not adequate) having a linear characteristic
Design pressure	5 bar
Test pressure	Refer to specification laid down by classification society
Press. drop across valve	Max. 0.5 bar
Controller	Proportional plus integral (PI), known as proportional plus reset for steady state error of max. $\pm 2^{\circ}\text{C}$ and transient condition error of max. $\pm 4^{\circ}\text{C}$
Temperature sensor	According to control valve manufacturer's specification; fitted in engine outlet pipe

4.3.3 Pre-heating

To prevent corrosive liner wear when not in service or during short stays in port, it is important that the ME is kept warm. Warming-through can be provided by a dedicated heater, using boiler raised steam or hot water from the diesel auxiliaries, or by direct circulation from the diesel auxiliaries.

Pre-heating from cooling water systems

If the requirement for warming-up is from the cooling water systems of the diesel auxiliaries, it is essential that the amount of heat available at normal load is sufficient to warm the main engine.

If the main and auxiliary engines have a cooling water system which can be cross-connected, it has to be ensured that, when the cross-connection is made, any pressure drop across the main engine does not affect the cooling water pressure required by the auxiliaries.

If the cooling water systems are apart, then a dedicated heat exchanger is required to transfer the heat to the main CCW system.

Pre-heating by direct water circulation

Use of main cylinder cooling water pump

If the main CCW pump is used to circulate water through the engine during pre-heating, then the heater is to be arranged parallel with the CCW system, and on/off control is to be provided by a dedicated temperature sensor at the CCW outlet of the engine. The flow through the heater is set by throttling discs, but not by valves.

Use of separate pre-heating pump

If the requirement is for a separate pre-heating pump, a small unit with 10% of the main pump capacity and an additional non-return valve between CCW pump and heater are to be installed. In addition, the pumps are to be electrically interlocked to prevent two pumps running at the same time.

Recommended temperature

The recommended temperature to start and operate the engine is 60°C at CCW outlet. If the engine is started below the recommended temperature, engine power must not exceed 80% of CMCR until the water temperature has reached 60°C.

The ambient engine room temperature and warm-up time are key parameters to estimate the heater power capacity required to achieve the target temperature of 60°C. The shipyard or ship designer should determine the ambient engine room temperature and the warm-up time (which may also be specified by the ship owner) on the basis of their own experience.

Warm-up time

The graph in [Figure 4-23](#), [4-38](#) shows the warm-up time needed in relation to the ambient engine room temperature to arrive at the heat amount required per cylinder. The graph covers the warming-up of engine components per cylinder, taking also the radiation heat into account.

The readable figure is then multiplied by the number of cylinders to show the heater capacity required for the engine.

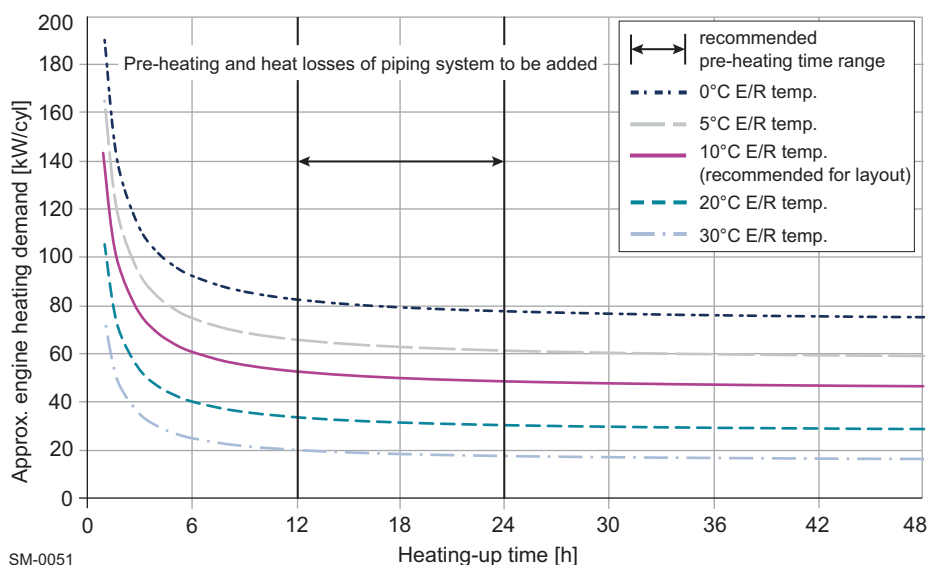

Figure 4-23 Pre-heating power requirement per cylinder

All figures are related to requirements of the engine and should only be used for a first concept layout of the heater capacity. However, during pre-heater selection the shipyard or ship designer must also consider further aspects such as heat losses in the external piping system, water volume inside the system, pipe lengths, volume of ancillary equipment, etc.

4.3.4 Freshwater generator

A freshwater generator, using heat from the cylinder cooling system to distil seawater, can be used to meet the demand for washing and potable water. The capacity of the freshwater generator is limited by the amount of heat available, which in turn is dependent on the service power rating of the engine.

NOTE

It is crucial in the design stage to ensure that there are sufficient safeguards to protect the main engine from thermal shock when the freshwater generator is started. To reduce such a risk, it is recommended to use valves (for instance butterfly valves), which are linked and actuated with a large reduction ratio, at the freshwater generator inlet and in the bypass line.



The latest version of the **Concept Guidance** for freshwater generator installation (DG 9721) is provided on the WinGD webpage under the following link:

[Freshwater generator installation](#)

4.3.5 Cooling water treatment

Correct treatment of the low- and high-temperature cooling water is essential for safe engine operation. Demineralised water or condensate according to the specifications in [Table 4-3](#) must be used as raw water. In the event of an emergency, tap water may be used for a limited period, but afterwards the entire cylinder cooling water system must be drained off, flushed, and recharged with demineralised water.

Table 4-3 Recommended specifications for raw water

Parameter	Value
pH at 20 °C	6.5 to 8.5
Max. dH	10° (corresponds to 180 mg/l CaCO ₃) ^{a)}
Max. chloride	80 mg/l
Max. sulphates	150 mg/l

a) In the case of higher values the water must be softened.

NOTE

Raw water from reverse osmosis technologies requires a minimum pH value of 6.0.

Corrosion inhibitors

In addition, the water used must be treated with a suitable corrosion inhibitor to prevent corrosive attack, sludge formation and scale deposits. For details refer to the chemical supply companies. Monitoring the level of the corrosion inhibitor and water softness is essential to prevent down-times due to component failures resulting from corrosion or impaired heat transfer.

NOTE

No internally galvanised steel pipes should be used in connection with treated freshwater, since most corrosion inhibitors have a nitrite base. Nitrites attack the zinc lining of galvanised piping and create sludge.



For further information about permissible cooling water additives please refer to the document **Cooling water and additives**, which is provided on the WinGD webpage under the following link:

[Cooling water and additives](#)

4.3.6 General recommendations for the cooling water system design

- The number of valves in the system must be kept to a minimum to reduce the risk of incorrect setting.
- Valves are to be locked in the set position and labelled to eliminate incorrect handling.
- After the system commissioning is completed, it is prohibited to manually interfere with the cooling water flow in different branches of the ME cooling water system by adjusting the valves or the orifice.
- Under normal operation of the cylinder cooling water system, the pump delivery head and the total flow rate are to remain constant, even when the freshwater generator is started up or shut down.
- The cylinder cooling water system is to be totally separated from steam systems. Under no circumstances must there be any possibility of steam entering the cylinder cooling water system, e.g. via a freshwater generator.
- The installation of equipment affecting the controlled temperature of cylinder cooling water (CCW) is to be examined carefully before being added. Uncontrolled increases or decreases in CCW temperature may lead to thermal shock of engine components and scuffing of pistons. Thermal shock is to be avoided, and the temperature gradient of the cooling water when starting and shutting down additional equipment is not to exceed two degrees per minute (2°C/min) at engine inlet.
- The design pressure and temperature of all the component parts such as pipes, valves, expansion tank, fittings, etc. are to meet the requirements of the classification society.

4.3.7 The EGC circulation water system

The EGC circulation water system is part of the iCER system. For details, refer to section [4.2.2](#), [4-6](#).

4.4 Lubricating oil systems



The latest version of the **Marine Installation Drawing Set** relevant for the lubricating oil system (DG 9722) is provided on the WinGD webpage under the following link:

[MIDS](#)

4.4.1 Lubricating oil requirements

The validated lubricating oils were selected in co-operation with the oil suppliers. In their respective product lines the products are considered as appropriate lubricants for the application indicated.

WinGD does not accept any liability for the quality of the supplied lubricating oil or its performance in actual service.



The validated cylinder and system oils are published in the document **Lubricants** provided on the WinGD webpage under the following link:

[Lubricants](#)

4.4.2 Main lubricating oil system

Field of application

Lubrication of the main bearings, thrust bearings and bottom-end bearings is carried out by the main lubricating oil system. The main lubricating oil system also operates the cooling of the piston crown with the efficient jet-shaker principle and the lubrication and cooling of the torsional and axial vibration dampers.

Figure 4-24 shows the general installation principle.

Lubrication of crosshead bearings

The crosshead bearings are lubricated by an additional crosshead pump (specification see [Booster pump for crosshead lubrication](#), 4-43).

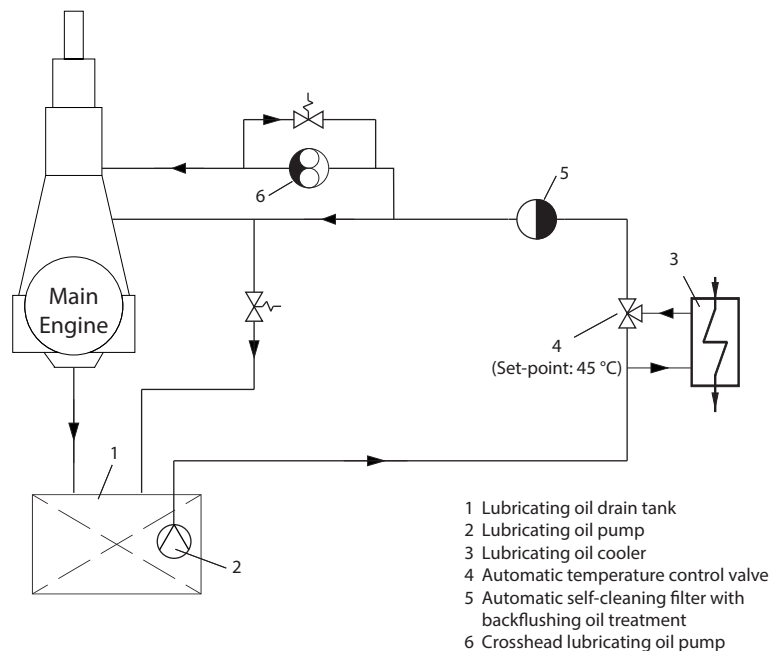

SM-0205

Figure 4-24 Lubricating oil system

*Main lubricating oil system components***Lubricating oil pump**

Positive displacement screw pumps with built-in safety valves, or centrifugal pumps (for pump capacities refer to *GTD*):

Type: Positive displacement screw pump	The flow rate is to be within a tolerance of 0 to + 10 % of the GTD value, plus: - back-flushing flow of automatic self-cleaning filter, if such filter is installed - oil flow to torsional vibration damper, if such damper is installed
Type: Centrifugal pump	The flow rate is to be within a tolerance of - 10 to + 10 % of the GTD value, plus: - back-flushing flow of automatic self-cleaning filter, if such filter is installed - oil flow to torsional vibration damper, if such damper is installed
Delivery head	The final delivery head to be determined is subject to the actual piping layout.
Working temperature	60 °C
Oil type	SAE30, 50 cSt at working temperature; when sizing the pump motor the maximum viscosity to be allowed for is 400 cSt.

Lubricating oil cooler

Type	Plate or tubular
Cooling medium	Freshwater
Cooling water flow	Refer to <i>GTD</i> .
Cooling water temperature	36 °C
Heat dissipation	Refer to <i>GTD</i> .
Margin for fouling	10-15% to be added
Oil flow	Refer to <i>GTD</i> .
Oil viscosity at cooler inlet	50 cSt at 60 °C
Oil temperature at inlet	Approx. 60 °C
Oil temperature at outlet	45 °C
Working pressure oil side	6 bar
Working pressure water side	Approx. 3 bar

Full-flow filter

The drain from the filter is to be sized and fitted to allow free flow into the lubricating oil drain tank.

The output required for the main lubricating oil pump to 'back-flush' the filter without interrupting the flow is to be taken into account when estimating the pump capacity (see [Lubricating oil pump](#), 4-42).

Type ^{a)}	Automatic back-flushing filter with differential pressure gauge and high-differential pressure alarm contacts. Designed to clean itself automatically using reverse flow or compressed air techniques. Back-flushing oil treatment by sludge checker.
Oil flow	Refer to GTD .
Working viscosity	95 cSt, at working temperature
Working pressure	6 bar
Test pressure	Specified by classification society
Diff. pressure, clean filter	Max. 0.2 bar
Diff. pressure, dirty filter	Max. 0.6 bar
Diff. pressure, alarm	Max. 0.8 bar Note: Real operational settings could be less according to filter maker's recommendation.
Mesh size	Sphere passing max. 0.035 mm
Filter material	Stainless steel mesh
Filter inserts bursting press.	Max. 3 bar differential across filter

a) Optional: changeover duplex filter designed for in-service cleaning, with differential pressure gauge and high-differential pressure alarm contacts

Booster pump for crosshead lubrication

Type	Positive displacement screw or gear types with built-in safety valves
Capacity	According to GTD : The flow rate is to be within a tolerance of 0 to 10% of the GTD value.
Delivery head	Refer to GTD .
Working temperature	Approx. 45 °C
Oil type	SAE 30, 95 cSt at working temperature; when sizing the pump motor the maximum viscosity to be allowed for is 400 cSt.

System oil

The pistons of the WinGD X82DF-2.0 engine feature highly efficient jet-shaker cooling. A validated system oil must be selected which fulfils the following basic properties:

- Additive-type oil
- A viscosity of SAE 30
- Minimum Base Number (BN)¹⁾ of 5.0 mg KOH/g
- Minimum failure load stage of 11 ± 1 related to the FZG gear oil test method A/8.3/90 according to ISO 14635-1²⁾
- Detergency properties
- Thermal stability
- Anti-corrosion properties
- Anti-foam properties
- Demulsifying performance

The consumption of system oil is given in [Table 1-4](#), [1-6](#).



The validated system oils which can be used for this purpose can be found in the document **Validated engine oils for WinGD engines** which is provided on the WinGD webpage under the following link:

[Validated engine oils for WinGD engines](#)



The system oil must be used according to the document **Lubricants** which is provided on the WinGD webpage under the following link:

[Lubricants](#)

4.4.3 Flushing the lubricating oil system



For flushing of the lubricating oil system refer to the latest version of the relevant **Instruction** (DG 9722), which is provided on the WinGD webpage under the following link:

[Instruction for flushing - Lubricating oil system](#)

4.4.4 Lubrication for turbochargers

As a standard, turbochargers are lubricated by the engine's system oil.

An external lubrication system for turbochargers is available as an option, which may use a different lubricating oil according to the turbocharger maker's specifications. The external lubrication system requires an additional storage tank, a lubrication pump, a fine filter and an oil cooler. For further details, please refer to the latest version of the MIDS for the lubricating oil system (DG 9722), [4-41](#).

1) The Base Number (BN), measured in mg KOH/g (test method ASTM D2896), is a measure of the alkalinity of the oil. The BN of the cylinder oil is not an index for detergency or for other properties of the cylinder oil.

2) The FZG gear machines located at the FZG Institute, Munich/Germany are the reference test apparatuses and must be used in the event of any uncertainty about test repeatability and reproducibility.

4.4.5 Cylinder lubricating oil system

Cylinder lubrication is carried out by a separate system, working with the once-through principle. A hydraulically actuated dosage pump feeds cylinder lubricating oil to the surface of the cylinder liner through quills in the liner. The oil feed rate is adjustable and set based on the piston underside drain oil analysis results.

For cylinder lubricating oil consumption refer to [Table 1-4](#), [1-6](#).

Cylinder lubricating oil

For normal operating conditions, a high-alkaline marine cylinder lubricating oil with a viscosity of SAE 50 and a minimum kinematic viscosity of 18.5cSt (mm²/s) at 100°C is recommended. The alkalinity of the oil is indicated by its BN.

Base number of cylinder lubricating oil

The BN of the cylinder lubricating oil must be selected depending on the total sulphur content of the fuel being burned.

Alternatives to a finished cylinder lubricating oil

The cylinder lubricating oil can also be blended/mixed on board. Multiple concepts for blending/mixing cylinder oil on board are available.

Another solution to have the required BN value available is to mix cylinder lubricating oils of different BN values.



The validated cylinder lubricating oils which can be used for this purpose can be found in the document **Validated engine oils for WinGD engines** which is provided on the WinGD webpage under the following link:

[*Validated engine oils for WinGD engines*](#)



The cylinder oil must be used according to the document **Lubricants** which is provided on the WinGD webpage under the following link:

[*Lubricants*](#)

Changeover between cylinder lubricating oils

There is an option to have two grades of cylinder lubricating oils available. A changeover between the cylinder lubricating oils can be initiated manually. In this case, two cylinder lubricating oil service tanks and a changeover device must be installed.

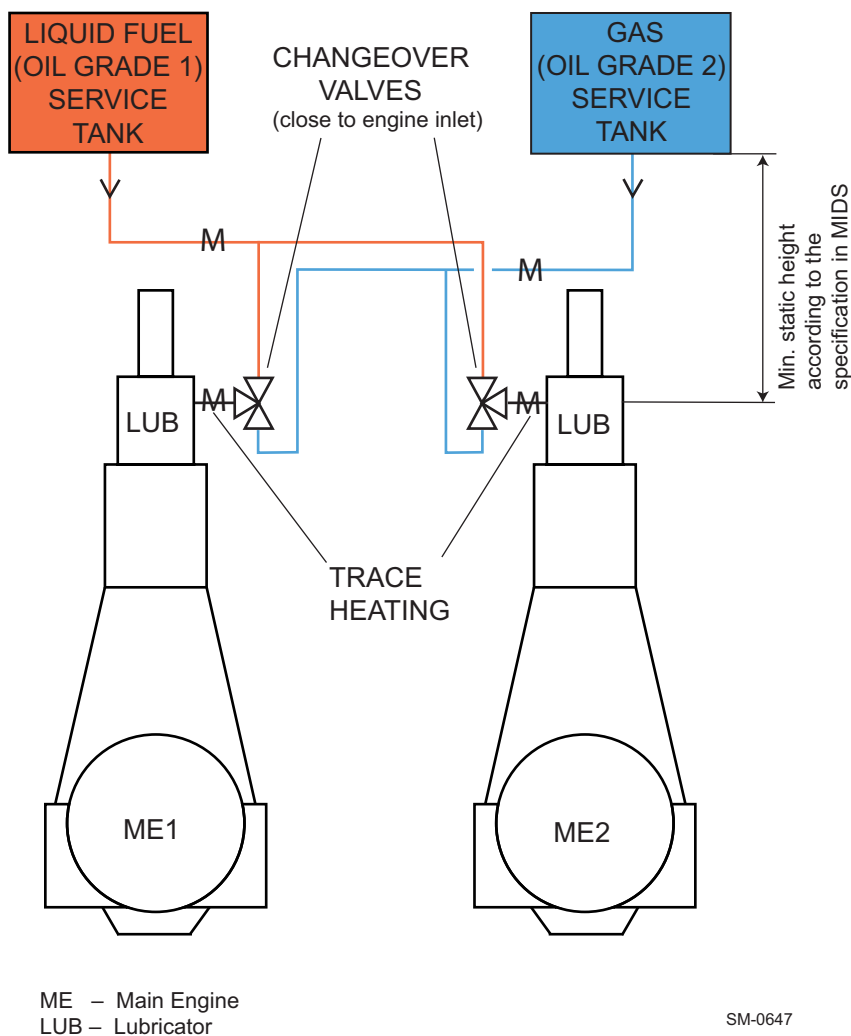
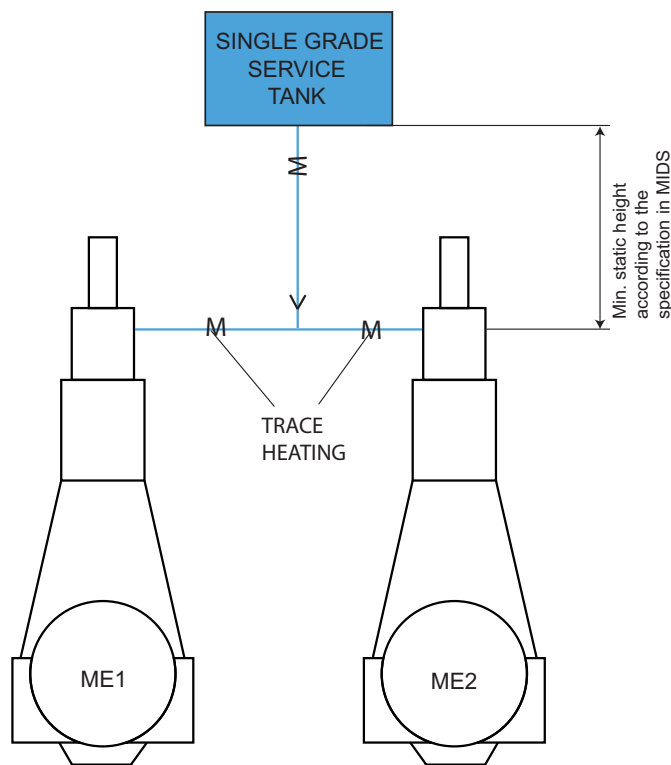

Figure 4-25 Dual cylinder lubricating oil installation, enabling independent gas and liquid fuel (maximum 0.50% m/m sulphur) operation with a manual changeover valve

Single grade cylinder lubricating oil application

In case the engine is specified for operation on liquid fuel with a sulphur content of up to 0.10% m/m sulphur (ultra low sulphur), then it is sufficient to install a single grade (low BN) cylinder lubricating oil service tank and consequently, no changeover device is required. The same is valid, if a single grade cylinder lubricating oil, typically in the BN 40 to 60 range, capable and approved of for handling both gas and diesel mode operation is selected.



ME – Main engine

SM-0411

Figure 4-26 Cylinder lubricating oil system for fuel with ultra low sulphur content (maximum 0.10% m/m sulphur) or alternatively, a single grade cylinder lubricating oil is applied for fuel with very low sulphur content (maximum 0.50% m/m sulphur)

Service tank and storage tank

The arrangement of the service tank and storage tank can be changed by locating the storage tank in place of the service tank. If this arrangement is preferred, the storage tank must be placed at the same height as the service tank to provide the required static pressure at the engine inlet. Furthermore, the storage tank must be of similar design, with a sloping floor.

Electrical trace heating for ship side cylinder lubricating oil piping

To ensure the correct cylinder lubricating oil temperature at the engine inlet (40+10/-5°C), electrical trace heating is recommended to be applied. The ME provides cabinet control box E86 for the heating cable connection and power supply. The heating cable together with the plug can be directly ordered from the engine maker. The guided heating cable length is determined by the cylinder LO pipe length and the engine type (see Table 4-4).

NOTE On the engine side, electrical trace heating is applied in the rail unit to keep the cylinder lubricating oil within the required temperature range, even during gas operation in cold areas.

Cylinder LO trace heating cable

WinGD specifies the 10QTVR2-CT self-regulating heating cable for the engine side and ship side cylinder LO piping. Detailed technical information about this cable can be found in *MIDS*. To reach the required LO temperature of 40+10/-5°C, the proper length of heating cable must be selected for the engine and traced along the ship side piping spirally or in parallel, depending on the cable/pipe ratio (see Figure 4-27).

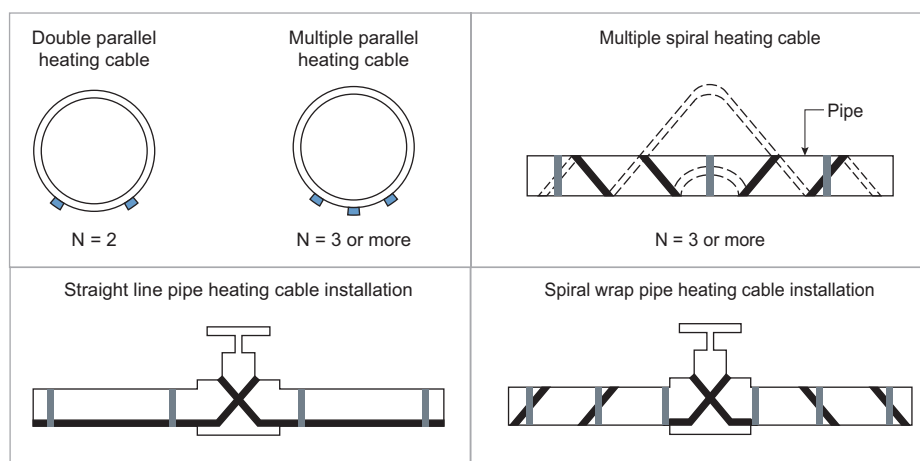

SM-0412

Figure 4-27 Trace heating cable arrangement

Considering the ME power, LO feed rate and environment condition, WinGD specifies a minimum heating cable length ‘Lc’ as listed in the following table:

Table 4-4 Heating cable specification

No. of cyl.	Min. heating cable length ‘Lc’ [m]
6	22
7	25
8	29
9	33

Considering the ship side cylinder LO pipe length ‘Lp’, the heating cable must be longer than the lubricating oil pipe, i.e. ‘Lc’ > ‘Lp’.

**Insulation of trace heated
cylinder LO pipe**

To maintain the desired temperature, the ship side cylinder LO pipe must be well insulated. The following requirements must be considered:

- Insulation material such as mineral wool, glass fibre, or other material of class approved type can be applied.
- WinGD recommends an insulation thickness of minimum 25 mm.

4.4.6 Maintenance and treatment of lubricating oil

It is essential that engine lubricating oil is kept as clean as possible. Water and solid contaminants held in suspension are to be removed using centrifugal separators which operate in bypass to the engine lubricating system.

Great care has to be taken of the separators and filters to ensure that they work correctly. The separators are to be set up as purifiers and completely isolated from the fuel oil treatment systems; there must be no possibility of cross-contamination.

Lubricating oil separator

Type	Self-cleaning centrifugal separator
Min. throughput capacity [l/h]	Refer to <i>GTD</i> .
Rated separator capacity	The rated or nominal capacity of the separator is to be according to the separator manufacturer's recommendations.
Separation temperature	90-95 °C; refer to manufacturer's instructions.

Lubricating oil samples

To ensure that representative samples of lubricating oil can be taken, dedicated sampling points (cocks) are provided on engine side. Such cocks need also to be installed on system side according to the relevant system proposal drawing in *MIDS*.

4.4.7 Drain tank

The engine is designed to operate with a dry sump: the oil returns from the bearings, flows to the bottom of the crankcase and through strainers into the lubricating oil drain tank. The drain connections from the crankcase to the drain tank are arranged vertically.

The drain tank is to be located beneath the engine and equipped with the following:

- Depth sounding pipe
- Pipe connections for lubricating oil purifiers
- Heating coil adjacent to pump suction
- Air vents with flame protection

NOTE	<p>The classification societies require that all drain pipes from the crankcase to the drain tank are taken as low as possible below the free surface of the oil to prevent aeration and foaming; they have to remain below the oil surface at all times. Strict attention has to be paid to this specification.</p>
-------------	---

There is to maintain adequate drainage under sea conditions resulting in pitching and rolling. The amount of lubricating oil required for an initial charge of the drain tank is indicated in Figure 4-28. The total tank size is normally 5-10% greater than the amount of lubricating oil required for an initial filling.

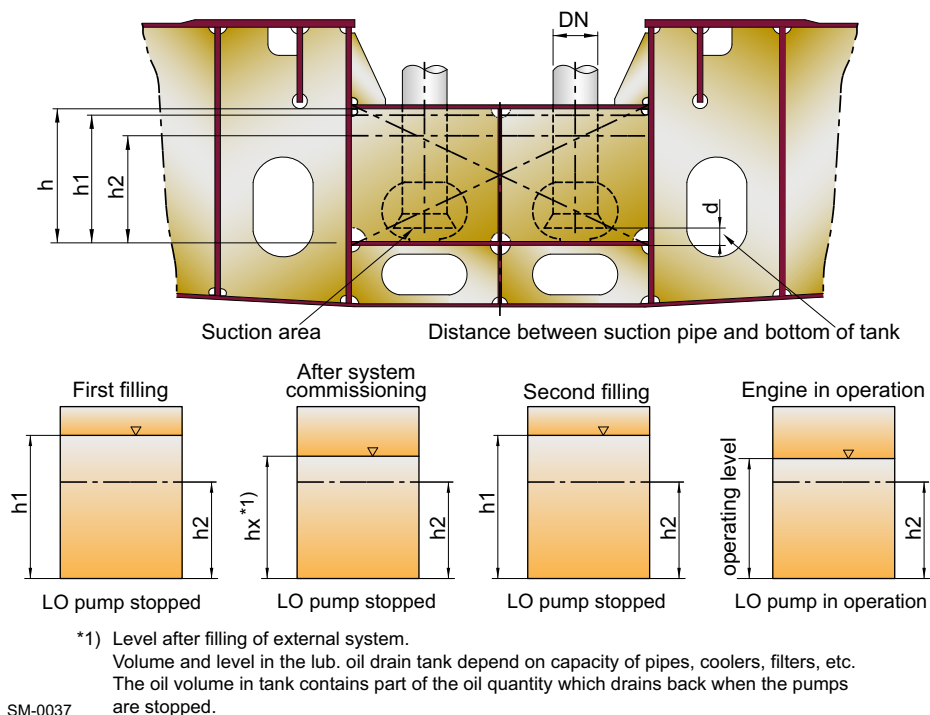
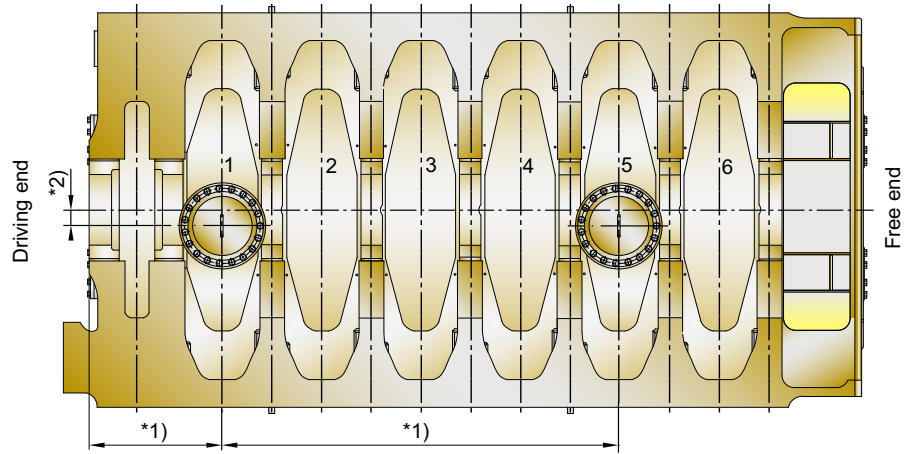

Figure 4-28 Dimensioning and filling process of lubricating oil drain tank

Arrangement of vertical lubricating oil drains



- *1) Proposal to determine final position in accordance with shipyard
- *2) Alternatively the oil drains may also be arranged symmetrically on port/fuel pump side.

SM-0038

Figure 4-29 Arrangement of vertical lubricating oil drains for 6-cylinder engines

NOTE	<p>The illustration above does not necessarily represent the actual configuration or the stage of development, nor the type of the engine concerned.</p> <p>For all relevant and prevailing information see MIDS drawings, 4-41.</p>
-------------	--

Inclination angles

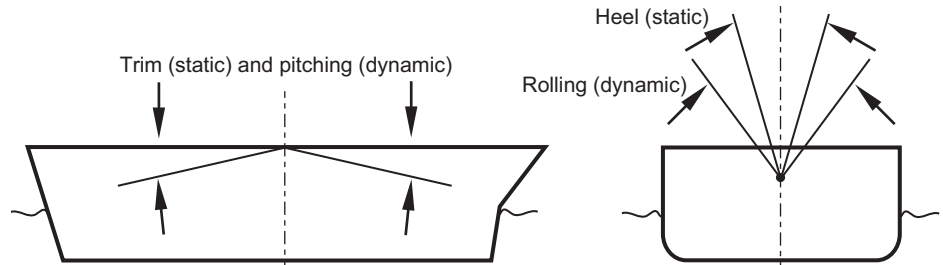

SM-0065

Athwartships and fore-and-aft inclinations may occur simultaneously.

NOTE

The data in the following tables represent the state of data as of the year 2023 and earlier. To obtain the latest data please contact the relevant classification society.

Table 4-5 Minimum inclination angles for full operability of the engine (1)

Classification societies (overview see Appendix, Table 9-1, 9-1)				
Year of latest update by Class	ABS 2022	BV 2022	CCS 2022	CRS 2020
Main and auxiliary engine				
Abbreviation	4/1/1/7.9	C/1/1/2.4	3/1/2/1.2.1	7/1/1.6/1.6.2
Heel to each side	15°	15°	15°	15°
Rolling to each side	22.5°	22.5°	22.5°	22.5°
Trim by the head ^{a)}	5°	5°	5°	5°
Trim by the stern ^{a)}	5°	5°	5°	5°
Pitching	±7.5°	±7.5°	±7.5°	±7.5°
Emergency sets				
Abbreviation	4/1/1/7.9	C/1/1/2.4	3/1/2/1.2.1	7/1/1.6/1.6.2
Heel to each side	22.5° ^{c)}	22.5°	22.5° ^{c)}	22.5° ^{c)}
Rolling to each side	22.5° ^{c)}	22.5°	22.5° ^{c)}	22.5° ^{c)}
Trim	10°	10°	10°	10°
Pitching	±10°	±10°	±10°	±10°
Electrical installation				
Abbreviation	4/1/1/7.9	C/1/1/2.4	4/1/2/1.2.1	7/1/1.6/1.6.2
Heel to each side	22.5° ^{b)}	22.5° ^{b) c)}	15° ^{c)}	22.5° ^{b)}
Rolling to each side	22.5° ^{b)}	22.5° ^{b) c)}	22.5° ^{c)}	22.5° ^{b)}
Trim	10°	10° ^{b)}	5°	10° ^{b)}
Pitching	±10°	±10° ^{b)}	±7.5°	±10° ^{b)}
<p>a) Where the ship's length exceeds 100m, the fore-and-aft static angle of inclination may be taken as 500/L degrees. (where L = length of ship in metres)</p> <p>b) Up to an inclination angle of 45 degrees, switches and controls are to remain in their last set position as no undesired switching operations or operational changes may occur.</p> <p>c) For ships carrying liquefied gases or chemicals the arrangement is to be such that the emergency power supply also remains operable with the ship flooded to a final athwartships inclination up to 30 degrees.</p>				

Table 4-6 Minimum inclination angles for full operability of the engine (2)

Classification societies (overview see Appendix, Table 9-1, 9-1)			
Year of latest update by Class	DNV 2022	IRS 2022	KR 2022
Main and auxiliary engine			
Abbreviation	4/1/3/2.2/2.2.1	4/1/1/1.7/1.7.1	5/1/103./1.
Heel to each side	15°	15°	15°
Rolling to each side	22.5°	22.5°	22.5°
Trim by the head ^{a)}	5°	5°	5°
Trim by the stern ^{a)}	5°	5°	5°
Pitching	±7.5°	±7.5°	±7.5°
Emergency sets			
Abbreviation	4/1/3/2.2/2.2.1	4/1/1/1.7/1.7.1	5/1/103./1.
Heel to each side	22.5° ^{c)}	22.5° ^{c)}	22.5° ^{c)}
Rolling to each side	22.5° ^{c)}	22.5° ^{c)}	22.5° ^{c)}
Trim	10° ^{a)}	10°	10°
Pitching	±10°	±10°	±10°
Electrical installation			
Abbreviation	4/1/3/2.2/2.2.1	4/1/1/1.7/1.7.1	5/1/103./1.
Heel to each side	22.5° ^{b) c)}	22.5° ^{b) c)}	22.5° ^{b) c)}
Rolling to each side	22.5° ^{b) c)}	22.5° ^{b) c)}	22.5° ^{b) c)}
Trim	10° ^{a) b)}	10° ^{b)}	10° ^{b)}
Pitching	±10° ^{b)}	±10° ^{b)}	±10° ^{b)}
<p>a) Where the ship's length exceeds 100m, the fore-and-aft static angle of inclination may be taken as 500/L degrees. (where L = length of ship in metres)</p> <p>b) Up to an inclination angle of 45 degrees, switches and controls are to remain in their last set position as no undesired switching operations or operational changes may occur.</p> <p>c) For ships carrying liquefied gases or chemicals the arrangement is to be such that the emergency power supply also remains operable with the ship flooded to a final athwartships inclination up to 30 degrees.</p>			

Table 4-7 Minimum inclination angles for full operability of the engine (3)

Classification societies (overview see Appendix, Table 9-1, 9-1)					
Year of latest update by Class	LR 2021	NK 2021	PRS 2022	RINA 2022	RS 2022
Main and auxiliary engine					
Abbreviation	5/1/3/3.7	D/1.3.1/6	VI/1/1.6.1	C/1/1/2.4	VII/2/2.3
Heel to each side	15°	15°	15°	15°	15°
Rolling to each side	22.5°	22.5°	22.5°	22.5°	22.5°
Trim by the head ^{a)}	5°	5°	5°	5°	5°
Trim by the stern ^{a)}	5°	5°	5°	5°	5°
Pitching	±7.5°	±7.5°	±7.5°	±7.5°	±7.5°
Emergency sets					
Abbreviation	5/1/3/3.7	D/1.3.1/6	VI/1/1.6.1	C/1/1/2.4	VII/2/2.3
Heel to each side	22.5° ^{c)}	22.5° ^{b) c)}	22.5° ^{c)}	22.5° ^{c)}	22.5° ^{c)}
Rolling to each side	22.5° ^{c)}	22.5° ^{b) c)}	22.5° ^{c)}	22.5° ^{c)}	22.5° ^{c)}
Trim	10°	10° ^{b)}	10°	10°	10°
Pitching	±10°	±10° ^{b)}	±10°	±10°	±10°
Electrical installation					
Abbreviation	6/2/1/1.10	H/1/1.1.7	VIII/2/2.1.2.2	C/2/2/1.6	XI/2/2.1.2.2
Heel to each side	15°	15° ^{c)}	15°	22.5° ^{b)}	15° ^{c)}
Rolling to each side	22.5°	22.5° ^{c)}	22.5°	22.5° ^{b)}	22.5° ^{c)}
Trim	5° ^{a)}	5° ^{a)}	5°	10° ^{b)}	5° ^{c)}
Pitching	±7.5°	±7.5°	±10°	±10° ^{b)}	±10° ^{c)}
<p>a) Where the ship's length exceeds 100m, the fore-and-aft static angle of inclination may be taken as 500/L degrees. (where L = length of ship in metres)</p> <p>b) Up to an inclination angle of 45 degrees, switches and controls are to remain in their last set position as no undesired switching operations or operational changes may occur.</p> <p>c) For ships carrying liquefied gases or chemicals the arrangement is to be such that the emergency power supply also remains operable with the ship flooded to a final athwartships inclination up to 30 degrees.</p>					

4.5 Fuel gas system

This section looks at the fuel gas system of the X-DF engines. There are currently two different devices to control the fuel gas pressure delivered to the X-DF engines:

- The Integrated Gas Pressure Regulation (iGPR) unit - 4.5.6, [4-73](#)
- The Gas Valve Unit (GVU) - 4.5.7, [4-75](#)

The iGPR is an on-engine solution, while the GVU is an off-engine solution. Therefore, the gas properties (see sections 4.5.3, [4-59](#) and 4.5.5, [4-69](#)) must be achieved either at the inlet of the iGPR or the inlet of the GVU. As the iGPR is on the engine, the engine inlet is identical to the iGPR inlet.



The latest version of the **Marine Installation Drawing Set** relevant for the fuel gas system (DG 9727) is provided on the WinGD webpage under the following link:

[MIDS](#)



The document **Flushing Instruction for Gas Fuel Piping System** is accessible under the following link:

[Flushing instruction - Gas fuel piping system](#)

4.5.1 Safety considerations

The engine room arrangement (the design and location of the equipment) and the type of systems installed vary depending on the ship installation. However, the main principles of gas safety and redundancy must meet the minimum requirements as defined in WinGD's Safety Concept and in the relevant codes and regulations, including the IGF and IGC Codes.



WinGD's **Safety Concept** is provided on the WinGD webpage under the following link:

[2-Stroke Dual-Fuel Safety Concept](#)

NOTE

Carefully read, understand and follow the instructions provided in the above-mentioned Safety Concept. This document is an important prerequisite for safe operation of the X-DF engine applications.

4.5.2 Operating principles

The WinGD X-DF engines are normally installed for dual-fuel operation, where the engine can operate in either gas or diesel mode. The operating mode can be changed while the engine is running, within certain limits, without interruption of power generation. If the fuel gas supply fails, then the engine will automatically trip to diesel mode operation.

The lean-burn concept

In gas operating mode, the X-DF engine runs as a lean-burn engine utilising natural gas as the main source of fuel. The fuel gas is supplied to the engine at low pressure. Gas ignition is initiated by injecting a small amount of pilot fuel (MDO / MGO), providing a high-energy ignition source for the main fuel charge (gas-air mixture) in the cylinder (see [Figure 4-30](#), [4-58](#)). Fuel gas admission is hydraulically actuated and electronically controlled.

With the lean fuel gas mixture it is possible to achieve good engine characteristics regarding output, efficiency and emissions. A lean fuel gas to air mixture is also utilised to avoid knocking. However, at high loads the misfiring limit gets closer to the knocking limit, which means that the available operating window is decreasing (see [Figure 4-31](#), [4-58](#)). Thanks to continuous combustion monitoring, the engine operation will remain in the correct operating window.

Combustion control for each cylinder

One of the key measures is to control the combustion process separately in each cylinder to remain within the operating window and have optimal performance under all conditions for each cylinder regarding safety, efficiency and emissions. The X-DF engine facilitates individual cylinder combustion control, which makes it possible to obtain optimal operating performance at conditions where gas quality, ambient temperature, etc. may vary.

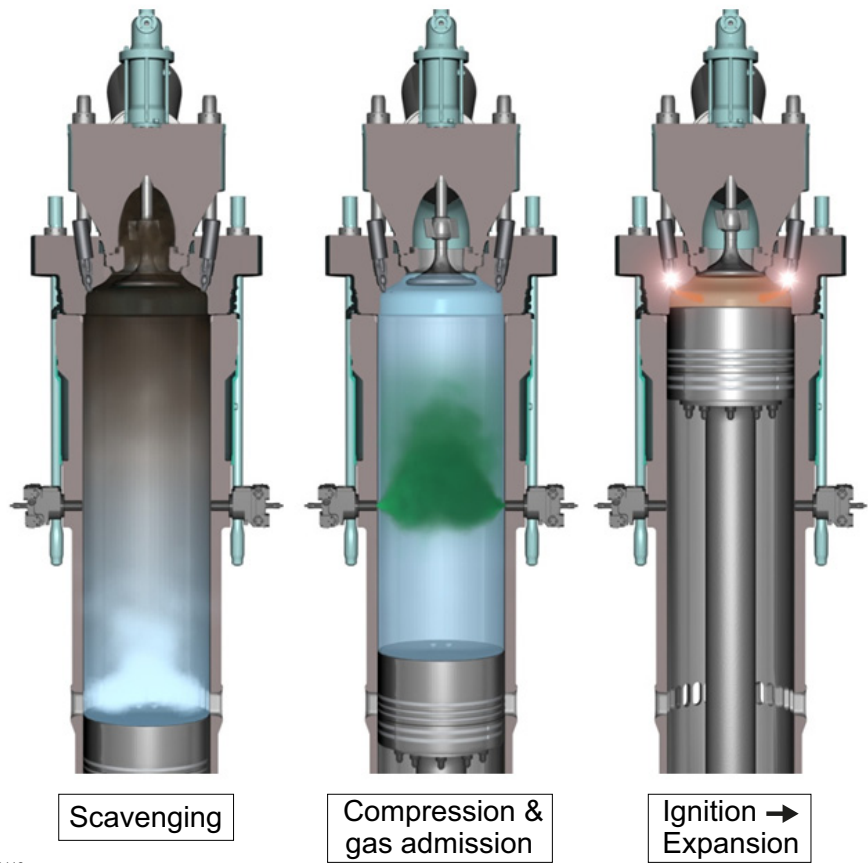

SM-0112

Figure 4-30 Lean burn with pilot ignition

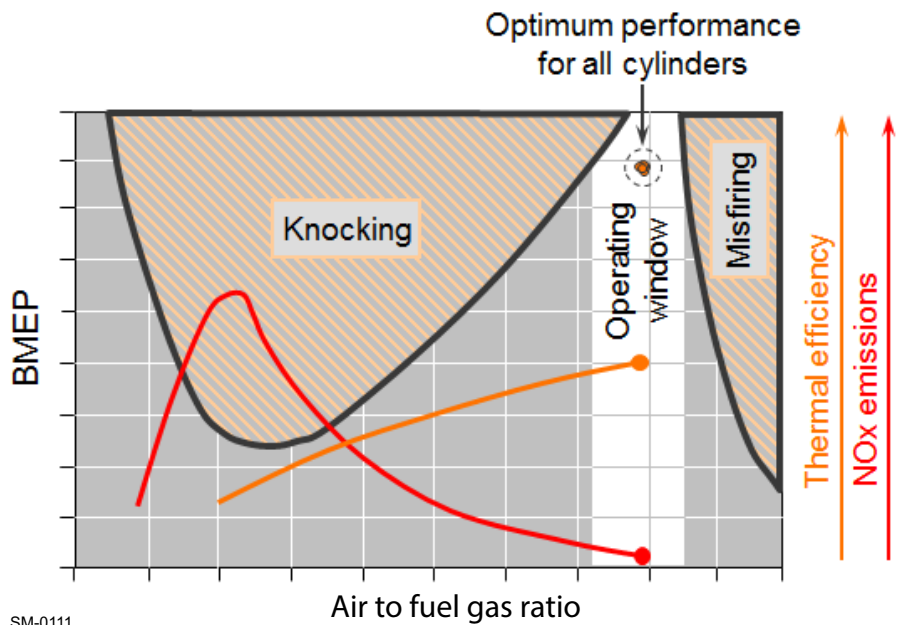

SM-0111

Figure 4-31 Lean-burn operation window

4.5.3 Gas specifications

As a dual-fuel engine, the X-DF engine is designed for continuous service in gas or in diesel operating mode. For continuous operation without reduction in rated output, the gas which is used as the main fuel in gas operating mode must fulfil the quality requirements provided in Table 4-8. The gas properties are defined at the engine inlet (for the iGPR, see section 4.5.6, ¶ 4-73) and the inlet of the gas valve unit (for the GVU, see section 4.5.7, ¶ 4-75).

Table 4-8 Gas specifications

Property	Value (values given in Nm ³ are at 0 °C and 101.3 kPa)
Lower Heating Value (LHV)	≥ 28 MJ/Nm ³
Minimum methane number	65 for 100 % engine power 60 for 85 % engine power
Influence of methane number on the maximum engine output	See Figure 4-32, ¶ 4-60.
Methane content	≥ 70 % volume
Hydrogen sulphide (H ₂ S)	≤ 0.05 % volume
Hydrogen (H ₂) ^{a)}	≤ 3 % volume
Ammonia	≤ 25 mg/Nm ³
Chlorine and fluorine	≤ 50 mg/Nm ³
Dew point of water	≤ -20 °C
Oil (aerosol liquid and vapour)	≤ 1 mg/Nm ³
Gas cleanliness	Gas is considered as sufficiently clean. ^{b)}
Gas temperature at relative inlet ^{c)}	0-60 °C. Note that no condensate is allowed in the annular space of the main engine gas piping. ^{d)}
Gas feed pressure ^{e)}	According to GTD
Permissible gas pressure fluctuation	± 0.6 bar (across all frequencies)

- a) Hydrogen content higher than 3 % volume must be considered on a project-specific basis.
- b) Contamination from the fuel gas supply system must be avoided, e.g. by correct pipe flushing, ensuring cleanliness of bunkering connections, etc.
- c) The gas properties are defined at the engine inlet (for iGPR, see section 4.5.6, ¶ 4-73) and the inlet of the gas valve unit (for GVU, see section 4.5.7, ¶ 4-75)
- d) If the gas temperature falls below the ambient air temperature (or the ambient air dew point, if determined), a dedicated dry air supply must be used from one of the following methods:
- from control air supply (ISO 8573-1, class x-4-x to be fulfilled, i.e. dew point ≤ 3 °C)
 - from air dryer (ISO 8573-1, class x-4-x to be fulfilled, i.e. dew point ≤ 3 °C)
 - from working air supply (as long as gas temperature is > 20 °C)
- e) The required gas feed pressure depends on the LHV as well as on the specific engine rating and actual engine load (specified in GTD). Details regarding feed pressure layout can be found in section 4.5.5, ¶ 4-69.

Methane number dependent engine output

The Methane Number (MN) has an influence on the maximum available power output.

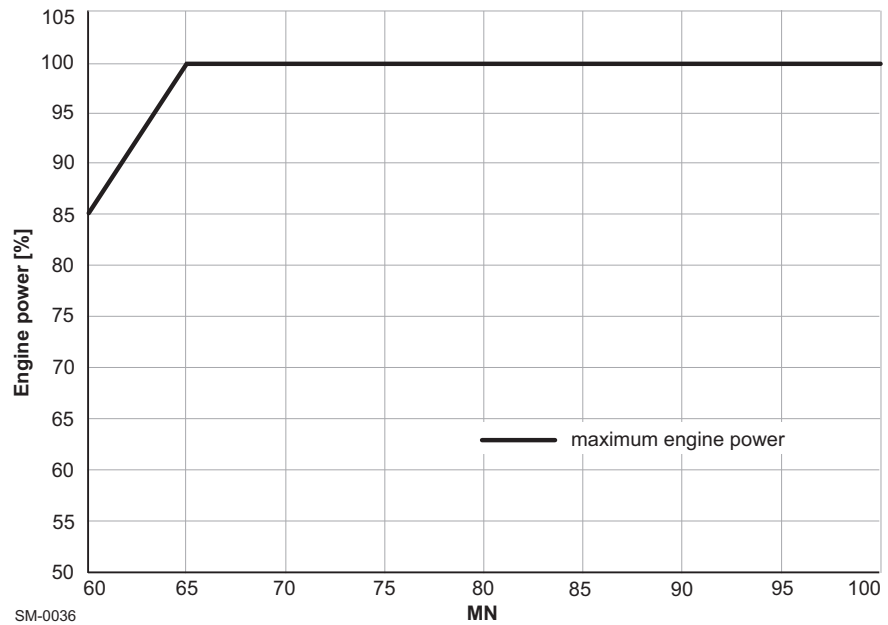

Figure 4-32 Maximum achievable power

Methane number calculation

An application provided by the European Association of Internal Combustion Engine Manufacturers (EUROMOT) allows calculating the methane number of natural gas mixtures. The application is free software and can be accessed with the following link:

<https://www.euromot.eu/wp-content/uploads/2019/07/MWM-MN-Code-for-distribution-2016-04-22.zip>

4.5.4 Fuel gas supply system

Fuel gas can typically be stored as LNG at atmospheric pressure, or be pressurised. The design of the external Fuel Gas Supply System (FGSS) may vary, however it should provide natural gas with the correct temperature and pressure to the engine. The gas piping can be of either single- or double-wall type according to its installation position in compliance with the relevant rules. Any gas pipe in the engine room must be of the double-wall type.

Master gas fuel engine valve

For dual-fuel engines, the IMO IGC and IGF Codes require a master gas fuel engine valve to be installed in the fuel gas feed system, outside of the engine room (see the 'Fuel Gas System' in the MIDS, 4-56). In addition, a manual shut-off valve must be placed upstream of the master gas fuel engine valve. Alternatively, the master gas fuel engine valve can be designed with manual override function.

To enable independent operation of different fuel gas consumers, it is recommended that each fuel gas consumer's supply line is equipped with an independent fuel gas shut-off valve. At least one of these shut-off valves should close in suitable time to prevent unnecessary venting of fuel gas or at least to restrict the amount of vented fuel gas.

Tank type

The best-suited tank type will depend on system requirements such as the necessary size, design pressure, the expected quantity of Boil-Off Gas (BOG), and the expected duration for the tank to hold the LNG (and resulting BOG).

As defined by the IMO, LNG tanks are classified as either 'Integrated' or 'Free-standing'. Free-standing tanks are then further classified as sub-types A, B and C. A description of the main tank types is provided below.

Integrated – Membrane tank

Integrated type tanks, such as a membrane tank, are built into the hull as part of the vessel structure to ensure an efficient utilisation of space. This is the defining feature compared to a free-standing tank (also known as an independent or self-supporting tank) which is not built into the hull. Integrated tanks are low-pressure tanks, designed for pressure less than 0.7bar(g). They are a common tank type option for LNGC cargo tanks and are appropriate for large LNG-fuelled vessels, such as container vessels, bulk carriers and oil tankers.

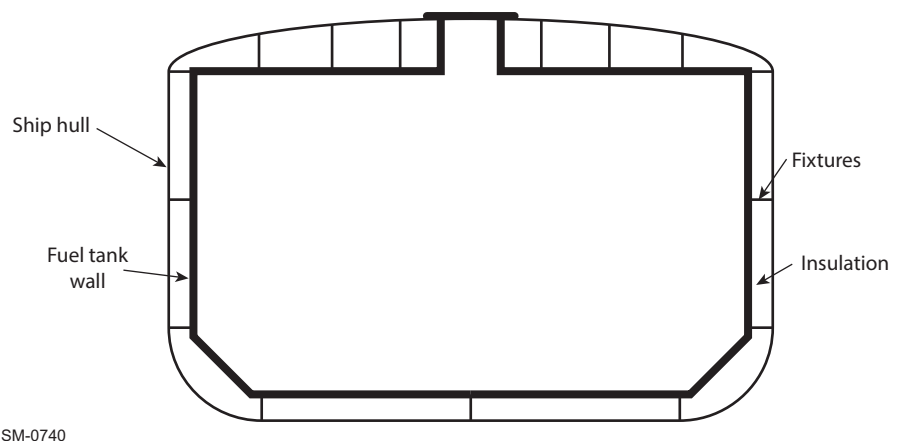
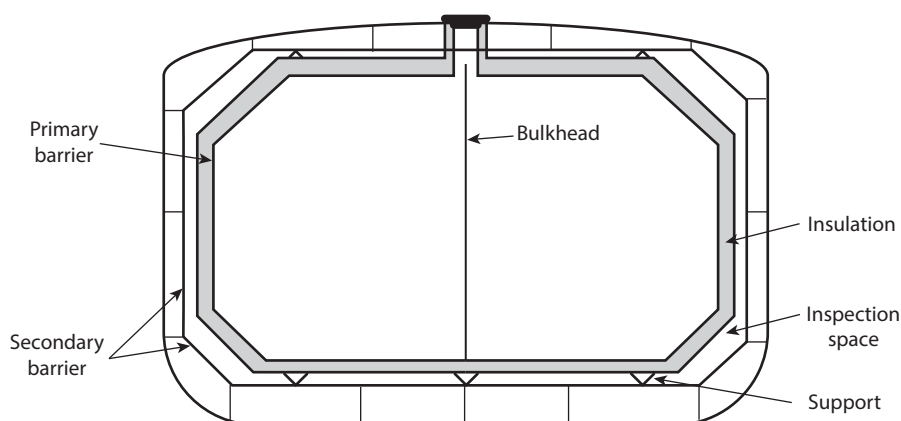

Figure 4-33 Section view of an integrated membrane tank

**Free-standing –
Type A tank**

As specified by the IGC Codes, the Type A tank must have a second barrier to withhold leaks. Often the ship hull is used as this second layer, so to maximise volume efficiency, the tank is designed in a prismatic shape to best fit inside the vessels hull. Between the tank wall and secondary barrier is a solid insulation layer and an air-gap layer. This reduces the thermal impact on the LNG from the environment, therefore reducing the BOG. This gap also allows for a given expansion of the tank wall, which is a result of the Type A tank design. The tank adjusts to the gas pressure due to its flexible structure. Therefore, it is very important to control the pressure increase, which must remain within a very limited pressure range (defined as non-pressurised tank), as otherwise structural damages would occur.



SM-0741

Figure 4-34 Section view of a free-standing Type A tank

**Free-standing –
Type B tank**

Same as the Type A tank, the Type B tank is also designed to be non-pressurised and will respond to pressure increase by expansion. Consequently, it is also important to control the pressure increase. The Type B tank design is based on a fail-safe concept. From crack monitoring and analysis, the 'Leak before Failure' approach of this design means that fatigue is progressive and not catastrophic. Therefore, it is only necessary to have a partial secondary barrier to hold the calculated maximum leakage. In the past, the Type B tank, referred to as the Moss type (see Figure 4-35), was spherical. This curve-designed shape supports the even distribution of stress across the tank walls. Nowadays however, the Type B tank (same as the Type A tank) is also available in a prismatic shape, having a partial secondary barrier.

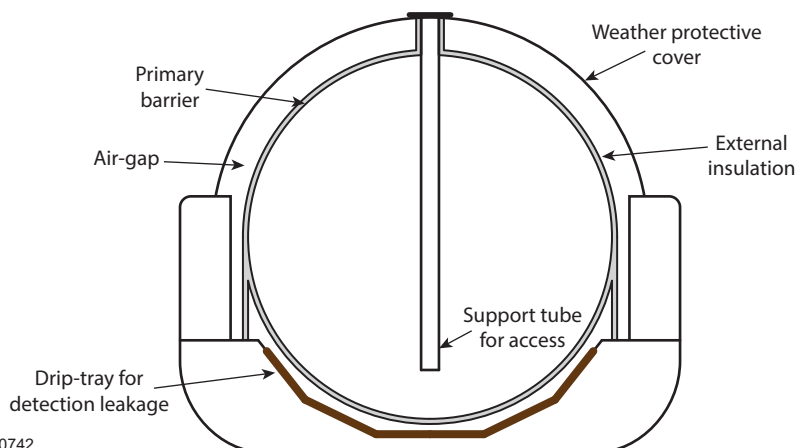

SM-0742

Figure 4-35 Section view of a free-standing Type B tank of moss design

**Free-standing –
Type C tank**

Type C tanks are designed using conventional pressure vessel codes for pressure ranges above 2 bar(g). The most common shapes for this type of tank are cylindrical and bi-lobe, which can be either vertically or horizontally mounted depending on the available space (Figure 4-36). While the cylindrical shape does not utilise the available space in an optimal way, the bi-lobe shape utilises the available space more effectively. The intersecting design of two cylinders makes use of the space between the two single cylinders, which otherwise would not be utilised. No secondary barrier is required for Type C tanks, but instead, gas leakage detectors are placed in the hold space.

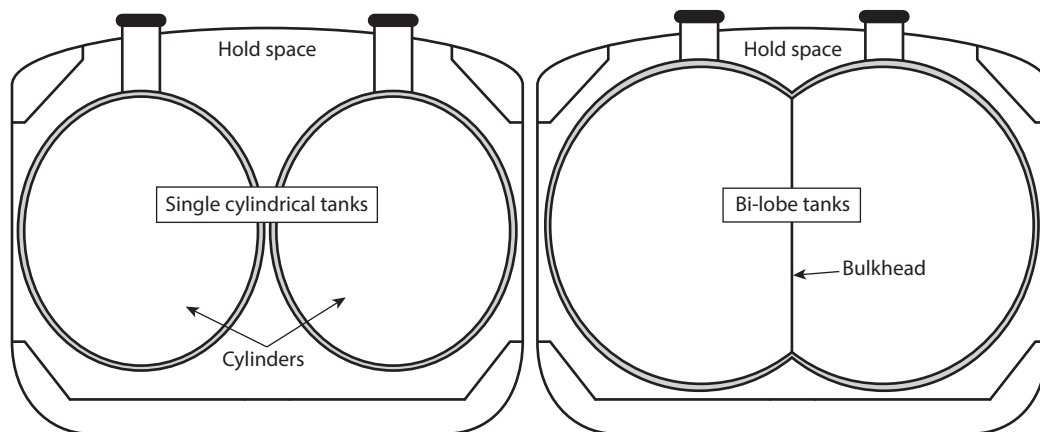

SM-0743

Figure 4-36 Section view of different free-standing Type C tanks installed below the deck

Depending on the arrangement of the vessel, the Type C tank can also be arranged top-side (on the deck) if this is preferred (see Figure 4-37). For example, this could be particularly useful if the hold space is used for other bulk materials. An advantage to this arrangement is that in the event of any leakage, the gas will not collect in an enclosed space, and will therefore reduce the risk of hazard.

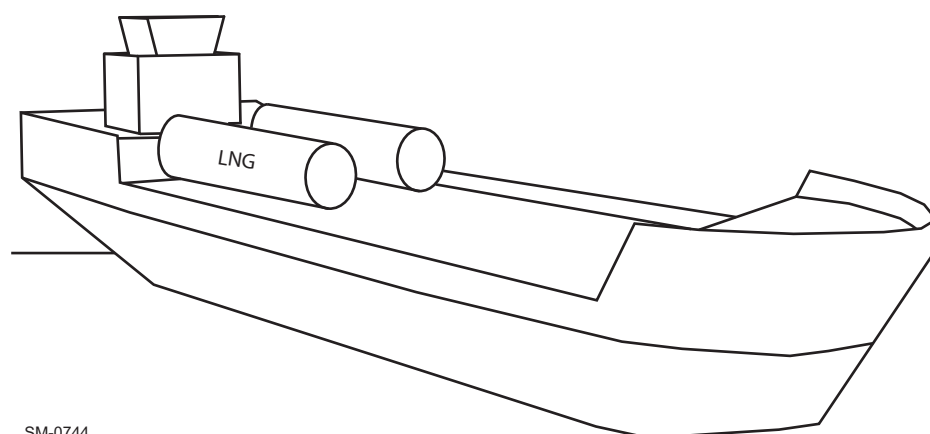

SM-0744

Figure 4-37 Type C tank on the deck of a vessel

Supplying fuel gas

The goal of the FGSS is to provide the fuel gas to the engine and gensets as required, and this must be achieved during engine operation and bunkering. The FGSS must be designed to handle variations in temperature and pressure. It is important to consider the processing of excessive Boil-Off Gas (BOG)¹⁾, including the suitability of an on-board re-liquefaction plant (see the subsection [Re-liquefaction process](#), ¶ 4-67).

Fuel gas is supplied to the main engine and gensets by the following two methods:

Forced boil-off gas supply

LNG is pumped from the tank by cryogenic submerged pumps to a vaporiser, where the liquid is converted to gas at the main engine's required pressure. As the LNG is forced to evaporate by an external heat source, the resulting gas is referred to as Forced Boil-Off Gas (FBOG). For WinGD's low-pressure X-DF engines this is at a maximum pressure of 16bar(g). The fuel gas produced from the vaporiser can also feed the gensets by passing through a pressure reduction valve to match the required pressure.

Natural boil-off gas supply

The heat which passes through the tank insulation causes the LNG to "boil", meaning that it evaporates and collects above the LNG. This gas is therefore a type of BOG and more specifically it is called Natural Boil-Off Gas (NBOG), as the source of the heat of evaporation is from the natural environment and not from any heating. In the sections that follow, the term NBOG is used to distinguish from FBOG. The relative amount of liquid in relation to the total tank volume, which evaporates from the LNG tank per day determines the Boil-Off Rate (BOR). The BOR is provided as a percentage value.

Over time, the NBOG will accumulate and raise the pressure in the system. To ensure that the pressure is not exceeding the safe level, the NBOG must be removed. Usually, the NBOG is used to power the main engine and the gensets. The NBOG can also be directed to a gas-fired boiler. The NBOG that is captured from the tank must be conditioned to meet the requirements of the main engine(s), the gensets, and the gas-fired boiler(s). This is accomplished by use of a combination of heat exchangers and NBOG compressor(s). If the gas cannot be consumed by the main engine(s) or the gas-fired boiler(s), then it can be released to the GCU.

Depending on the expected amount of NBOG and the desired level of system flexibility, the NBOG can exclusively fuel the gensets with forced boil-off of LNG as a supplement (see [Figure 4-38](#), ¶ 4-65), or alternatively, the NBOG can fuel the main engine(s) directly as well as the gensets, while having the possibility to supplement with forced boil-off from LNG (see [Figure 4-39](#), ¶ 4-66). For further flexibility, the NBOG can be returned to the tank after a re-liquefaction process, or alternatively, the BOR can be controlled by cooling the LNG.

1) In general, the term BOG is used to describe the boil-off gas which is produced from evaporation in the tank by natural heat input. As the source of the heat of evaporation is from the natural environment and not from any other heating, BOG is also called Natural Boil-Off Gas (NBOG). In this document, the term NBOG is used to differentiate it from Forced Boil-Off Gas (FBOG).

Pressurised FGSS

If an LNG tank is designed to withstand pressure (along with the FGSS), then generally the system will be less complex than a system with a non-pressurised tank (along with the FGSS). The system will be less complex since the NBOG management will not be as demanding as for the other non-pressurised systems. Two examples of solutions for a non-LNGC FGSS are provided.

Type C tank – Solution 1

Figure 4-38 shows a pressurised Type C tank where fuel gas is provided to the main engine only as FBOG and where only the gensets utilise the NBOG. If required, the gensets have the possibility to supplement with forced boil-off from LNG. In many cases, the amount of NBOG being generated can be consumed by a single gas-fuelled genset. This makes solution 1 a simple and cost efficient solution, as only a low-pressure NBOG compressor may be required, depending on the design tank pressure and the gas feed pressure demand of the gensets.

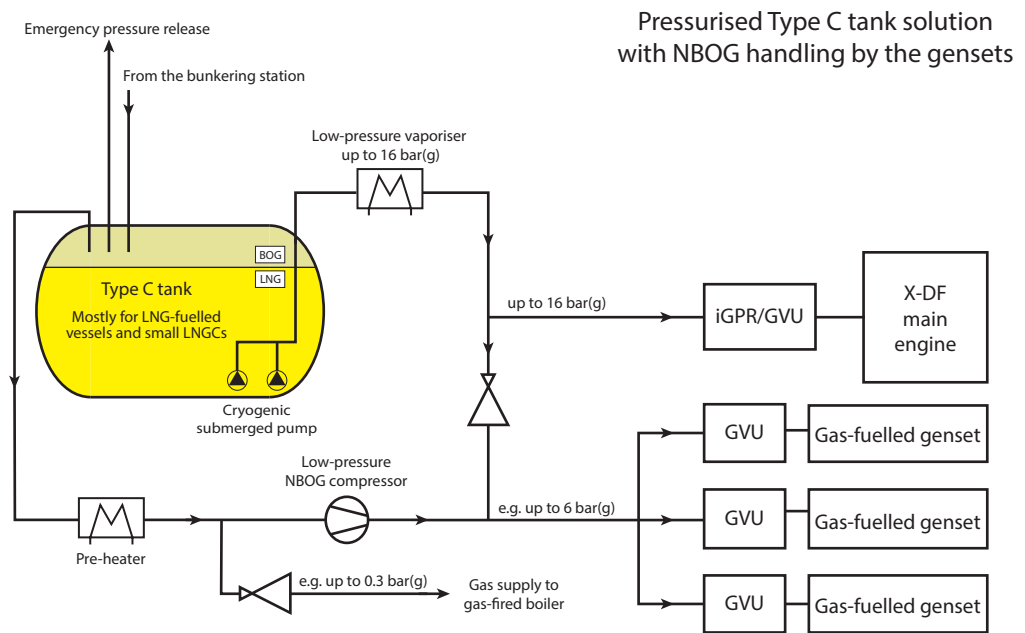

Pressurised Type C tank solution with NBOG handling by the gensets

SM-0681

Figure 4-38 Pressurised Type C tank solution with NBOG handling by the gensets

Type C tank – Solution 2

Figure 4-39, 4-66 shows a pressurised Type C tank where fuel gas is provided to the main engine as a combination of FBOG and NBOG. The gensets are fed by a reduction valve from the main engine supply. This system design ensures that the NBOG is also utilised, even when the generated NBOG is greater than the genset consumption. However, this additional flexibility comes at a greater cost as the NBOG compressor is designed for a higher delivery pressure.

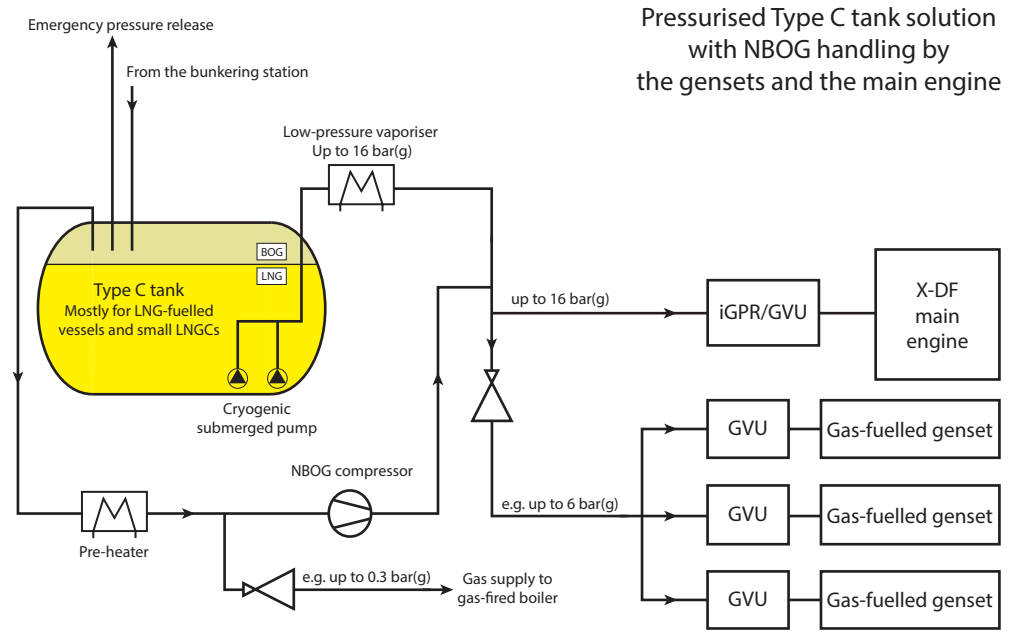

SM-0684

Figure 4-39 Pressurised Type C tank solution with NBOG handling by the gensets and the main engine

Non-pressurised FGSS

For larger LNGCs it is more common to use non-pressurised cargo tanks, therefore the NBOG management must ensure that the pressure build-up does not exceed the tank design limits during bunkering and sea voyages. Like in a pressurised FGSS, a non-pressurised FGSS can combine both FBOG and NBOG to fuel the main engine(s) and gensets as required. In addition, a re-liquefaction system can be added as shown in Figure 4-40. This allows for surplus NBOG to be returned to the tank in liquid form and ensures that the pressure in the FGSS will not exceed the limits.

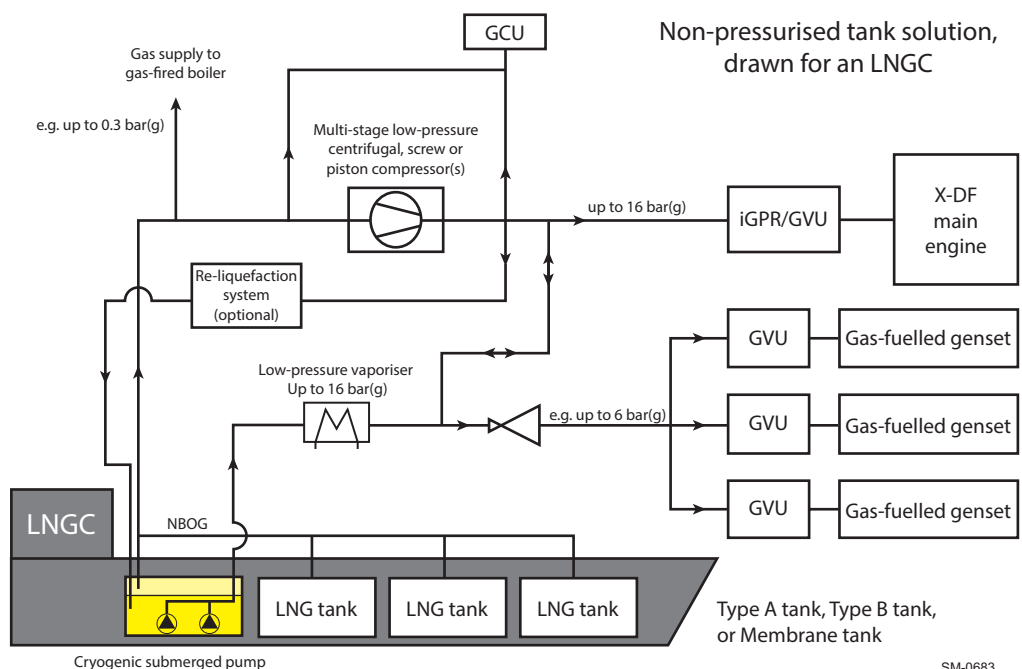

SM-0683

Figure 4-40 Non-pressurised tank solution, drawn for an LNGC

Re-liquefaction process

An on-board re-liquefaction system recovers excess NBOG in the FGSS and returns it to the cargo tanks. This re-liquefaction process reduces the pressure in the system without having to dispose the fuel gas through the GCU, which is also known as NBOG flaring. This is important during voyages as well as in port, as cargo tank pressure requirements must be met. The re-liquefaction of NBOG also slows down the 'LNG ageing'. LNG ageing means the reduction of the methane content in the LNG composition, resulting in lowering the methane number.

There are two basic methods of cooling within a re-liquefaction plant. These methods are often used in many different combinations, resulting in re-liquefaction of the NBOG. These two basic methods are described in detail below.

Cooling by the Joule-Thompson effect

The Joule-Thompson effect is the change in temperature that is experienced by a gas when subjected to a change in pressure. Within a re-liquefaction system, if the NBOG from the tank is pressurised through a compressor, it will cause the NBOG to heat up. If the NBOG is then again cooled before reducing its pressure (by a release valve), then its temperature can fall below its boiling point. This will cause the NBOG to partially return to liquid, while the rest remains gaseous, but at the very cold boiling temperature. This cold boiling temperature is utilised in the cooling process of the compressed NBOG.

Cooling by the Reversed-Brayton effect

The alternative method for cooling is a refrigeration process where a heat exchanger is able to remove enough heat from the NBOG, so that it falls below its boiling point without any pressure changes. This is normally achieved by a nitrogen cooling system which provides sufficient cooling capacity to the heat exchanger. This principle is known as the Reversed-Brayton effect.

These two basic methods can be used together in different system configurations to offer the best results and efficiency for re-liquefying the NBOG. After being cooled, it must then be passed through a separator to remove any NBOG that has not condensed. After this point, the NBOG which has not been condensed is then normally recirculated back to the beginning of the re-liquefaction process, while the LNG generated from the re-liquefaction process is then returned to the LNG tank(s).

Sub-cooling method

The process of spraying sub-cooled LNG into the top of the tank is an alternative approach for indirectly handling the NBOG. This method of managing the system pressure is different compared to the direct handling of the NBOG. Instead of returning the NBOG to its liquid state, a sub-cooler aims to continuously cool the LNG below its boiling point, therefore preventing it from reaching its boiling temperature. As seen in [Figure 4-41](#), [Figure 4-68](#), the LNG is pumped from the tank and after sub-cooling it is returned back to the tank. The LNG is either returned by spraying it from the top of the tank into the gas layer above the LNG level, or by mixing it into the LNG in the tank. The process of spraying helps to reduce the tank pressure.

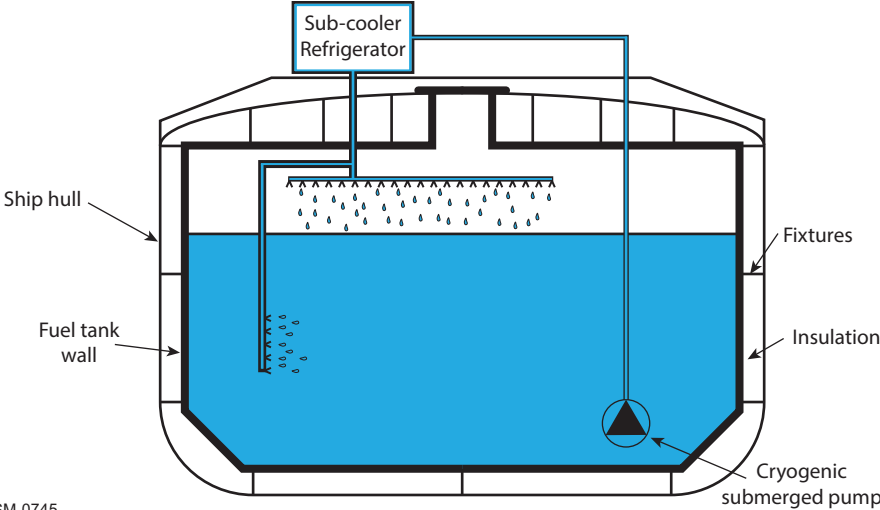

Figure 4-41 An LNG sub-cooler within an integrated tank

The advantages of this approach are that it is a much simpler system setup requiring usually a smaller plant size. As a result, it also requires less maintenance, while being more energy efficient. However, a sub-cooler system is normally not suitable for Type A and Type B tanks.

4.5.5 Fuel gas supply pressure

Layout of the fuel gas supply system

The engine and the FGSS are laid out such that unrestricted engine power output is ensured for all gas qualities down to a lower heating value of 28 MJ/Nm³. This is typically the lowest value of LNG’s natural boil-off gas composition with high nitrogen content (approximately 22%), as it can be found on LNG carriers at the beginning of laden voyages.

The design limit of gas pressure regulating equipment for both the iGPR (see section 4.5.6, ¶ 4-73) and the GVU (see section 4.5.7, ¶ 4-75) is 16bar(g).

For the specific project, the gas piping class can be defined according to the design fuel gas supply pressure specified in the following paragraphs, with the consideration of pressure fluctuation and safety a margin for pressure losses.

Design fuel gas supply pressure selection

The fuel gas supply at the iGPR or the GVU inlet is defined (at 100% CMCR engine power output) with a design supply pressure of 15bar(g). This includes a margin of 1 bar to the maximum FGSS design pressure which is 16bar(g). However, as indicated in Figure 4-42, the minimum required fuel gas supply pressure at the iGPR or the GVU inlet is a function of the actual engine power output.

NOTE The minimum fuel gas supply pressure is independent from the engine rating and the LHV when it is in the range of 28-36 MJ/Nm³.

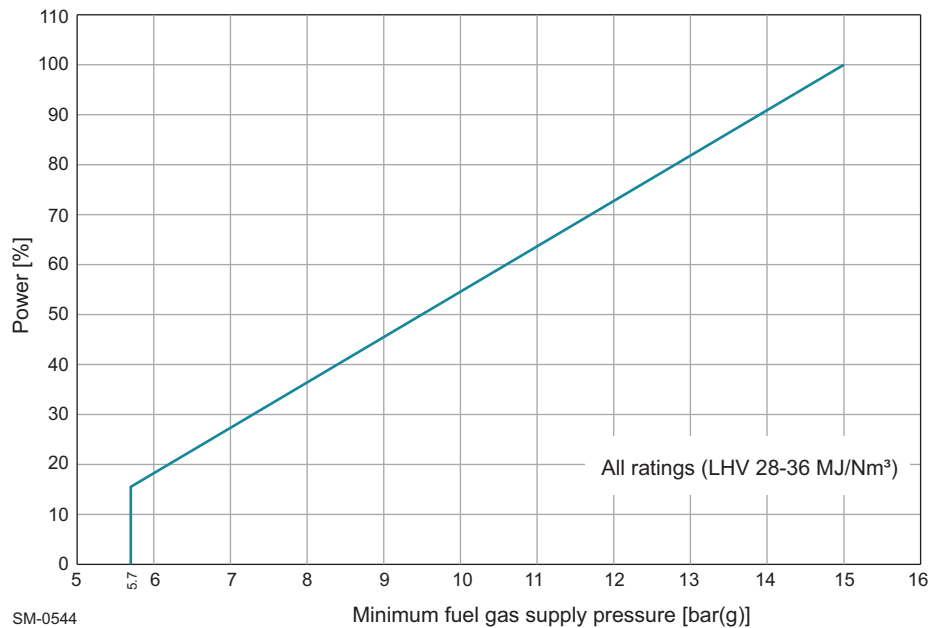

SM-0544 **Figure 4-42 Design fuel gas supply pressure requirements**

The minimum gas pressure values (as seen in Figure 4-42) at the iGPR or the GVU inlet, do not account for the pressure drop between the iGPR or the GVU inlet and the FGSS. Therefore, when designing the FGSS, consideration must be given to the pressure loss of the FGSS (which must be calculated by the shipyard or FGSS supplier, see section 4.5.6, ¶ 4-73), as well as the maximum fuel gas supply pressure fluctuation.

NOTE

The use of fuel gas with an LHV below 28MJ/Nm³ has not been validated. If used, it must be accepted that the engine power output may be limited.

NOTE

If the gas combustion unit is supplied by the compressor, then the compressor flow capacity is defined by the natural boil-off rate.

Fuel sharing operation

If the main engine is operating in fuel sharing mode, the required minimum fuel gas supply pressure is according to the engine power, as indicated in [Figure 4-42](#), [Figure 4-69](#). However, the fuel gas flow rate will vary depending on the mixture ratio of fuel gas and fuel oil.

Advantage of variable fuel gas supply pressure

WinGD recommends energy-saving variable fuel gas supply pressure to the iGPR or the GVU inlet. If the fuel gas is supplied by means of a compressor, the savings can be significant, while for supply by means of an LNG pump, the savings are minor. For LNG pump operation, the pressure adaptation has the additional advantage of creating less heat input into the LNG tank by reducing the pump's mechanical work. Finally, variable fuel gas supply pressure supports stable engine operation at minimum power. However, constant fuel gas supply pressure is possible but not recommended because of the reasons mentioned before.

Pressure control of the FGSS with iGPR

The Engine Control System (ECS) determines the set-point of the fuel gas supply pressure and transmits the controlling signals to the Propulsion Control System (PCS) and the iGPR. The PCS transmits the set-point to the FGSS (see [Figure 4-43](#), [Figure 4-71](#) for basic information about the control system interfaces).

The data transmitted to the FGSS includes an additional pressure offset to accommodate for pressure losses and dynamic load changes in the system. The pressure offset is a project-specific input that is calculated and set in the PCS.

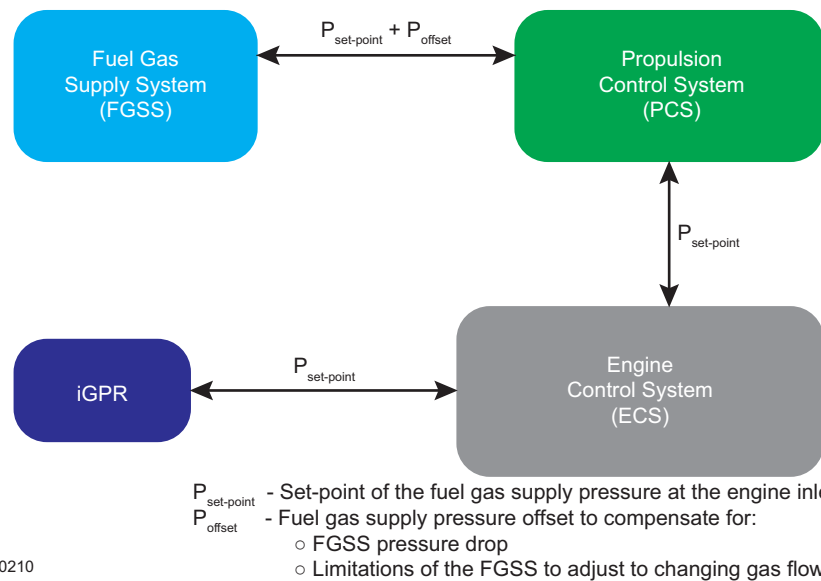

Figure 4-43 Fuel gas supply pressure control at the engine inlet (engines with iGPR)

Pressure control of the FGSS with GVU

The ECS determines the set-point of the fuel gas supply pressure at the GVU inlet and transmits the controlling signals to the PCS, which then requests pressure increase or decrease from the GVU. In addition, the PCS transmits the set-point to the FGSS (see Figure 4-44 for basic information about the control system interfaces).

The data transmitted to the FGSS includes an additional pressure offset to accommodate for pressure losses and dynamic load changes in the system. The pressure offset is a project-specific input that is calculated and set in the PCS.

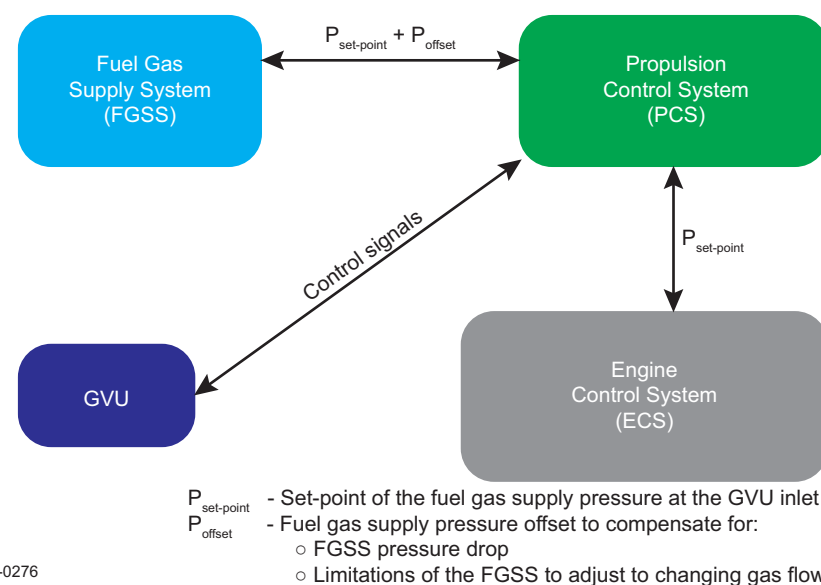

Figure 4-44 Fuel gas supply pressure control at the GVU inlet (engines with GVU)

Pressure control of the engine's operational gas pressure

The operational gas pressure at the engine's internal Gas Admission Valves (GAVs) is controlled by the iGPR (see section 4.5.6, 4-73) or the GVU (see section 4.5.7, 4-75). Both the iGPR or the GVU are connected to the ECS (either by means of the PCS, or directly). The iGPR or the GVU preferably just provide fine adjustments of the gas supply pressure to compensate for fluctuating pressure demands. These varying pressure demands may be caused by fluctuations of the engine power demand. At the same time, the FGSS provides the gas supply pressure as requested by the PCS. However, the iGPR or the GVU have the capacity to handle any gas supply pressure up to the maximum design gas supply pressure of 16bar(g).

Overview of steps for acquiring the FGSS delivery pressure

Figure 4-45 provides an overview of the gas pressure from the FGSS input by way of the iGPR or the GVU inlet to the final pressure level at the engine's gas admission valves.

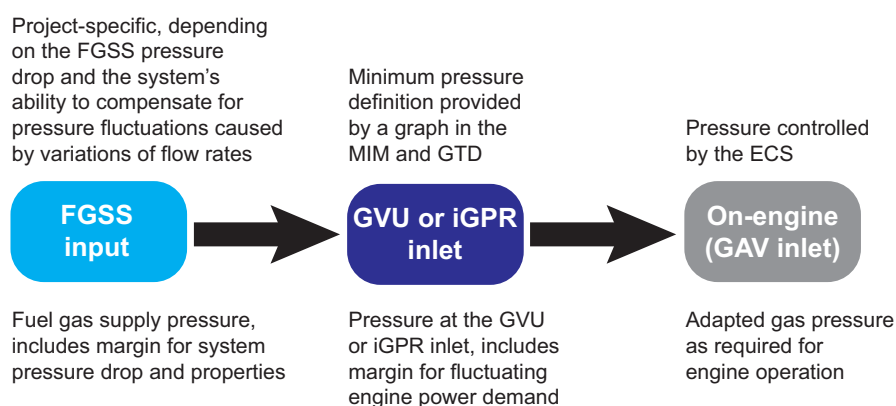

SM-0773

Figure 4-45 Fuel gas pressure level definitions

4.5.6 On-engine integrated gas pressure regulation unit

The X-DF engine requires precise regulation of gas pressure with a timely response to changing load conditions. WinGD has developed the Integrated Gas Pressure Regulation (iGPR) unit, which encompasses all performance and safety requirements associated with the X-DF engine applications (see Figure 4-46).

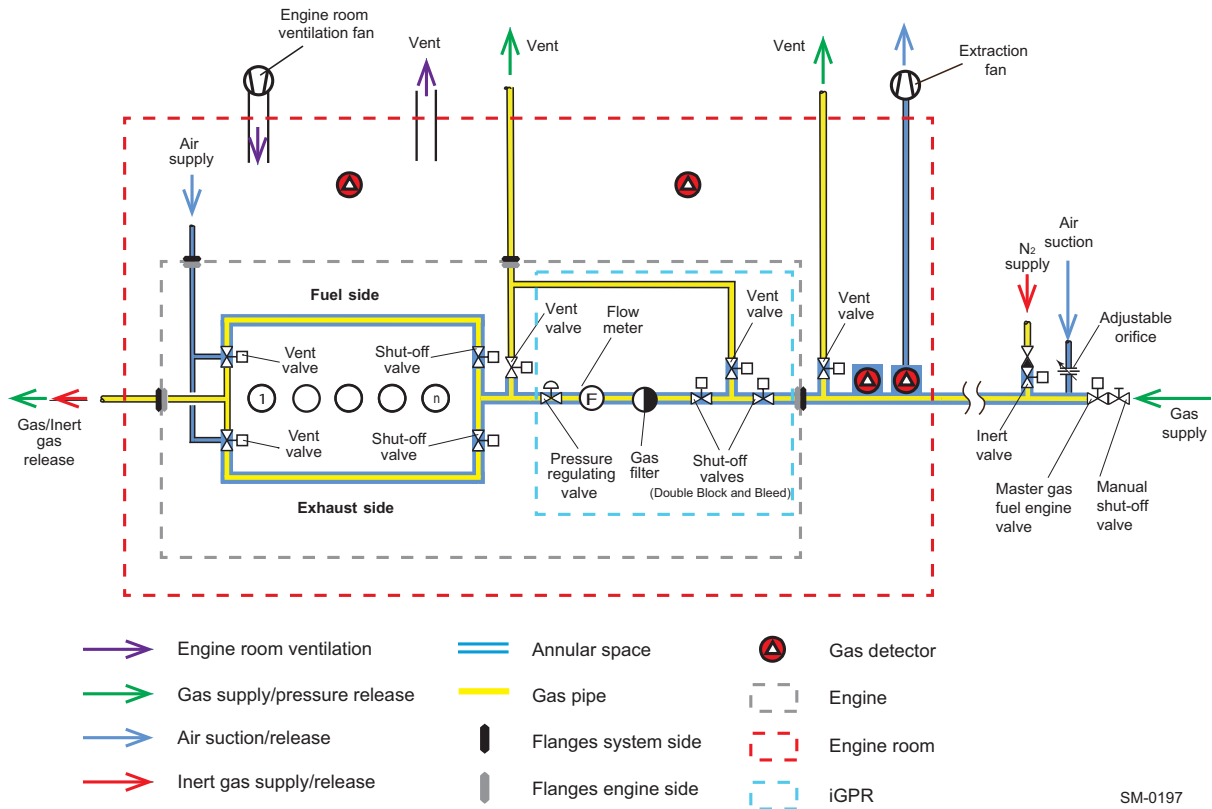

Figure 4-46 Fuel gas supply system with the iGPR

The main functions of the iGPR include:

- Gas pressure regulation
- Gas flow measurement
- Gas filtration
- Leak test sequence
- Purging with inert gas and venting
- Fuel gas temperature monitoring

The iGPR is mounted on the engine and has the same installation principles as applied to the fuel gas supply system which is located in the engine room.

The iGPR consists of the following main components:

Fuel gas pressure regulating valve

The fuel gas feed pressure to the engine must be adjusted within a narrow, load-dependent pressure range. This adjustment will ensure that the fuel gas pressure in the engine's common-rail piping fits to the load command. This is done by means of a pressure regulating valve that is controlled by the ECS.

Fuel gas shut-off valves

The fuel gas shut-off valves as installed in the iGPR are normally closed type valves which are open during gas operation. It is used to shut off the fuel gas supply to the pressure regulating valve and the engine, while also providing piping isolation for on-engine purging.

Purging and venting valves

The iGPR is installed with multiple valves that isolate inert gas and vent lines from the main fuel gas piping. In the event that a gas trip is initiated by the safety system, these valves are automatically opened. Inert gas is then supplied to the iGPR, and the engine's fuel gas system is purged of gas. Manual activation of the valves is available for fuel gas system maintenance.

Flow meter

Fuel gas consumption is measured by a Coriolis flow meter.

Gas filter

Fuel gas supply to the iGPR is filtered using an integrated gas filter.

Control system

The control system is based on the same hardware and reliable components as used on the engine itself. The complete iGPR control is allocated in the iGPR control box. Based on signals from the control system logic, the solenoids control the pneumatically actuated valves. A control panel is mounted on the iGPR control box, where the status of all valves and readings from sensors are displayed.

4.5.7 Off-engine gas valve unit

Before being supplied to the engine, the fuel gas passes through the Gas Valve Unit (GVU), which is a module connected to the engine’s fuel gas supply piping. This unit controls the fuel gas pressure to the engine depending on the engine load. As a safety precaution to ensure the tightness of valves and proper functioning of components, the GVU performs a gas leakage test before the engine starts operating on fuel gas.

WinGD supports two different types of gas valve units:

GVU without housing The GVU without housing, e.g. GVU-OD™ (open design) from Wärtsilä (see Figure 4-47), must be installed in an explosion-proof GVU room.

GVU within a housing The GVU within a housing, e.g. GVU-ED™ (enclosed design) from Wärtsilä (see Figure 4-48, 4-76), is a solution where all the equipment is mounted inside a gas-tight casing. This arrangement minimises installation costs, as it allows the GVU-ED™ to be placed inside the engine room, next to the engine in a similar manner as other auxiliary equipment.

GVUs from other suppliers can be applied if fulfilling the same functionalities as specified in this document. For dimensional GVU drawings or for further information on the product, please contact the GVU supplier.

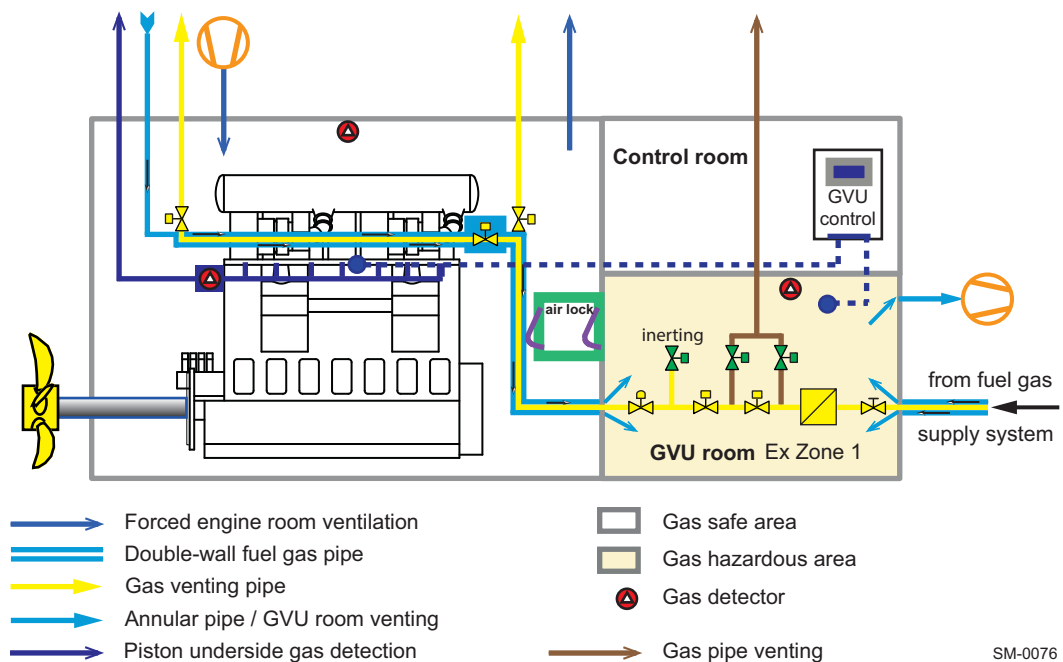
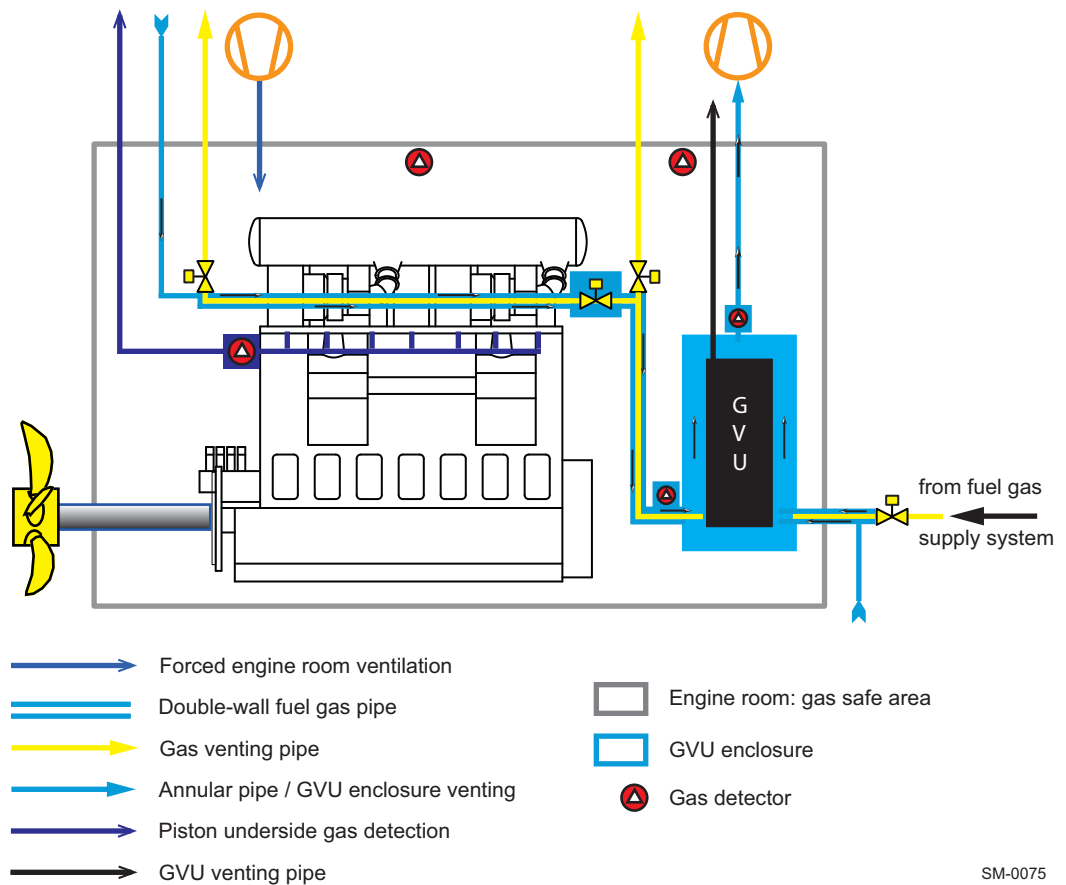

Figure 4-47 The GVU-OD™ from Wärtsilä

SM-0076



SM-0075

Figure 4-48 The GVU-ED™ from Wärtsilä

Location of the GVU

The fuel gas supply pipe length between the GVU and the engine inlet should be kept as short as possible (maximum length 30 m) to ensure optimal engine response to transient conditions.

The GVU consists of the following main components:

Fuel gas pressure regulating valve

The fuel gas feed pressure to the engine must be adjusted within a narrow, load-dependent pressure range. This adjustment will ensure that the fuel gas pressure in the engine's common-rail piping fits to the load command. This is done by means of a pressure regulating valve that is controlled by the PCS. A smaller gas volume between the pressure control valve and the engine improves the response time of the system in transient conditions, such as engine load fluctuations.

Valve block

The 'Interim guidelines on safety for natural gas-fuelled engine installations in ships' (IGF Code) state that each item of gas-consuming equipment must be provided with a set of valves to form a double block-and-bleed function and thus ensures reliable and safe operation on fuel gas.

Gas filter The filter is a full-flow unit, preventing impurities from entering the engine's fuel gas system. The pressure drop over the filter is monitored and an alarm is activated when the pressure drop is higher than the permitted value, which is caused by a dirty filter.

Control system Readings from the sensors on the GVU as well as the opening and closing of valves are electronically or electro-pneumatically controlled by the GVU control system. The Local Display Unit (LDU), which is mounted on the control cabinet, indicates all valve statuses and readings from sensors.

4.5.8 Fuel gas venting

During normal operation of the X-DF engine, there are certain situations defined where the fuel gas piping must be safely depressurised. For example, during a stop sequence in gas operation mode, the gas venting valves on the iGPR or GVU, as well as on the engine itself will automatically open to quickly reduce the gas pressure to atmospheric pressure. Also, in case of an emergency stop, an additional pressure relief valve in the FGSS will release pressure from the fuel gas piping, upstream of the iGPR or GVU.

Venting of fuel gas This small amount of fuel gas can be released outward to a place carrying no risk of ignition. Instead of venting to the atmosphere, other means of disposal such as a suitable furnace or gas-recovery system can be considered. However, this kind of arrangement must be accepted by the classification society on a case-by-case basis.

NOTE

- All venting pipes that may contain fuel gas must be designed to prevent the accumulation of fuel gas inside the piping.
- The pressure drop in the venting lines must be kept to a minimum.

Interconnection of vent lines To prevent gas venting to another engine during maintenance, vent lines from the fuel gas supply (or from the iGPR or GVU) of different engines must not be interconnected. However, vent lines from the same engine can be interconnected to a common header.

Ventilation of double-wall fuel gas piping

All fuel gas piping on the engine is of the double-wall type. The annular space in the double-wall piping is ventilated by suction pressure, as created by a ventilation fan. WinGD recommends having the ventilation fan installed in a safe location outside of the engine room. Differing layouts (for installation within the engine room) can also be considered, given prior acceptance from the responsible flag state and or the classification society. The ventilation fan's suction side is connected to the ventilation outlet pipe just before the engine inlet in the case of an iGPR installation. Alternatively, the connection is on the top of the GVU.

Location of ventilation air inlets One ventilation air inlet to the annular space is located on the engine. The ventilation air is to be taken from a safe area through dedicated piping. The second ventilation air inlet is located at the other end of the fuel gas supply double-wall piping, and in a safe area outside of the engine room.

With this arrangement, the ventilation air is taken from both inlets and flows through the double-wall piping annular space to the ventilation fan's suction side. The correct flow distribution between both venting paths must be set by adjusting the orifices as shown in the 'Fuel Gas System' of the MIDS, [4-56](#).

Extraction fan capacity

The extraction fan capacity is calculated for an air flow rate that ensures air exchanges of no less than 30 times per hour. The volume of extraction air depends on the volume of the annular space of the main engine's and the FGSS's double-wall piping, including the GVU volume, if a GVU is applied. The on-engine flow resistance in the annular space is provided in the 'Fuel Gas System' of the MIDS, [4-56](#). The extraction fan must not be connected to any other consumer's FGSS.

According to requirements of classification societies, spare parts should be available for each type of fan, except if a second fan is mounted as redundancy.

Dry air supply for annular space ventilation

If the fuel gas temperature is below the dew point of the annular space ventilation air, then dry air needs to be supplied for the engine's annular space ventilation to prevent condensation. This can be achieved by supplying compressed air (working air at 7-8 bar(g) is sufficient). For further details, please see the system proposal as shown in the 'Fuel Gas System' of the MIDS, [4-56](#). The compressed air capacity must be designed such that the volume of the annular space can be ventilated at a minimum of 30 times per hour. Some design margin must be included for the layout uncertainties, as well as to account for air loss through the flow indicator as applied in the MIDS installation proposal.

Hazardous area

According to the IGC/IGF Code a 1.5 metre hazardous area around both the ventilation air inlet and outlet must be taken into consideration when designing the ventilation piping.

4.5.9 Purging by inert gas

Purging and flushing of the fuel gas system is performed in case of fuel gas leakage detection, a fire alarm or any other emergency, and before maintenance on the main engine, the iGPR or the GVU. The fuel gas piping system must be depressurised and any remaining fuel gas must be removed by an inert gas (e.g. nitrogen). For this purpose, the piping of the WinGD main engine and the iGPR or the GVU are equipped with inert gas connections.

Purging gas properties

For purging, WinGD requires an inert gas (typically nitrogen) with the following properties:

Table 4-9 Purity of inert gas (engines with iGPR)

Requirement	Property	Value
IGF requirements	Content of mixture out of N ₂ , CO ₂ , Ar	≥ 95.0 %
	Oxygen content	≤ 5.0 %
WinGD requirements	Dew point (atmospheric pressure)	≤ -40 °C
	Inert gas pressure before purging valve	Set-point ± 10 %
	Set-point selection range	5-15 bar(g)

Table 4-10 Purity of inert gas (engines with GVU)

Requirement	Property	Value
IGF requirements	Content of mixture out of N ₂ , CO ₂ , Ar	≥ 95.0 %
	Oxygen content	≤ 5.0 %
WinGD requirements	Dew point (atmospheric pressure)	≤ -40 °C
	Inert gas pressure before purging valve	Set-point ± 10 %
	Set-point selection range	3-15 bar(g)

Purging gas pressure

The purging gas pressure (p_i) can be selected within a wide range to allow the best match with the available purging gas system. Once the purging gas pressure has been selected (defined as set-point), the actual purging gas pressure may deviate ± 10% from the set-point. As the purging cycle is time-controlled and is programmed during commissioning, the pressure set-point must be fixed beforehand.

Purging gas consumption volume

The inert gas consumption for one purging cycle must be a minimum of three times the fuel gas pipe volume. The inert gas volume can be calculated with the following equation:

$$V_i = 3V_a \text{ [Nm}^3\text{]}$$

where:

V_i = minimum required inert gas volume [Nm³]

V_a = total volume of the space to be purged, including the main engine's internal gas piping, the external gas supply piping and the relevant fittings [m³]

The main engine's internal gas piping volume, which must be purged, can be found in the 'Fuel Gas System' of the MIDS, 4-56. The volume of the fuel gas piping on the ship side must be calculated by the shipyard and must be based on the piping layout. The main engine control system has a pre-set inert gas purging cycle of 25 seconds. The value for this purging cycle must be adjusted during commissioning.

The design principles of an inert gas release valve are similar to that of a safety valve. The valve opening section is designed based on the desired flow velocity and the pressure differential before and after the valve. The valve supplier must provide a suitable valve for the calculated V_i and the selected p_i as well as the resulting purging duration time. Shipyards can consult the supplier of the inert gas release valve for more details.

Inert gas supply for the main engine is one part of the inert gas supply on the vessel. Therefore, the inert gas consumption of the main engine must be added to the ship's inert gas system during the design phase.

4.5.10 Fuel gas leak test

After first-time system assembly or maintenance work on the fuel gas piping, a leak test of the fuel gas pipe on the engine side and plant side is required to ensure that the fuel gas pipe is tight and that the components in the gas piping are working properly. The fuel gas leak test can be carried out with compressed air from the starting air system. The air pressure must be reduced to the fuel gas supply pressure as defined in section 4.5.5, 4-69. A temporary connection must be arranged (please refer to the MIDS drawing, 4-56).

NOTE If the inert gas pressure is equal to or higher than the design fuel gas supply pressure, then it can be used instead of compressed. This can be carried out by means of a pressure reduction valve. In this case, a branch connection from the starting air system to the gas fuel piping is not necessary.

The fuel gas leak test can be activated from the engine's LDU. The test is automatically done sequentially for the three sections of the fuel gas pipe, as shown in Figure 4-49 and Figure 4-50.

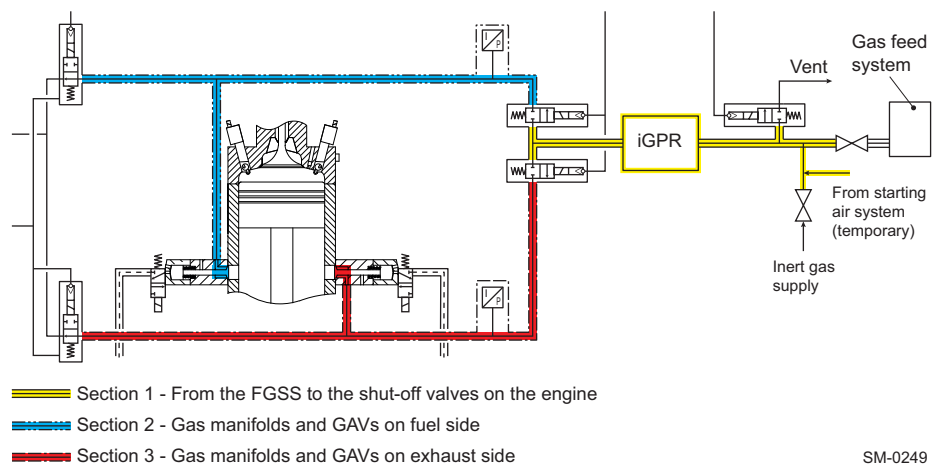

Figure 4-49 Gas leak test sequence (engines with iGPR)

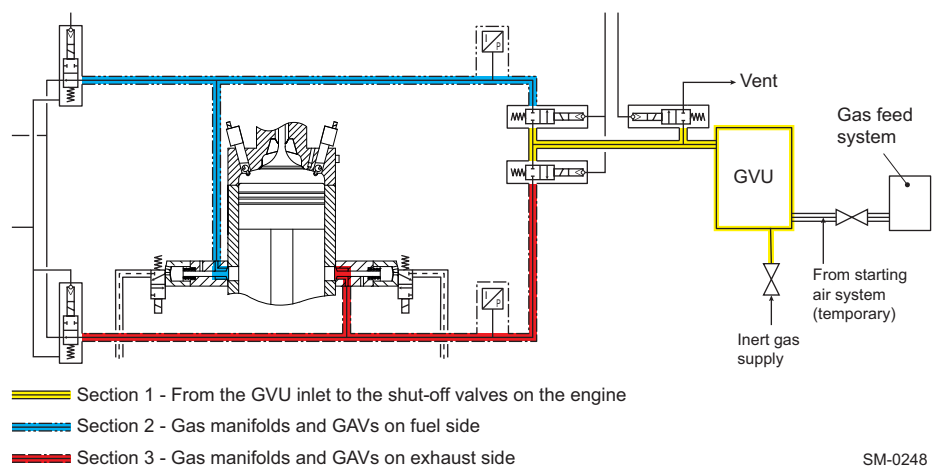

Figure 4-50 Gas leak test sequence (engines with GVU)

4.6 Pilot fuel oil system



Relevant installation information for the pilot fuel system is included in the fuel oil system **Marine Installation Drawing Set** (DG 9723), which is provided on the WinGD webpage under the following link:

[MIDS](#)

Flushing the pilot fuel oil system and treatment of pilot fuel oil

The requirements for flushing the pilot fuel oil system and for the treatment of pilot fuel oil are similar to those described in the fuel oil system sections (see sections 4.7.3, 4-98 and 4.7.4, 4-99).

Functionality

The pilot fuel system operates during all engine operating modes (gas, diesel and fuel sharing operation) as outlined in section 1.3 **Fuel operating modes**, 1-7. Pilot fuel is injected into the combustion chamber to ignite the gas charge. The pilot fuel system is designed for operation on MDO (DMB, DFB grades) and MGO (DMA, DFA, DMZ, DFZ grades). The diesel oil is delivered by a fuel oil feed pump via a diesel oil cooler and a filter to the engine as shown in [Figure 4-51](#).

Sulphur content

In general, the pilot fuel sulphur content must comply with the limits of the applicable emission regulations. Project-specific exceptions might be granted in some areas on certain conditions, e.g. continuous sulphur emission measurements.

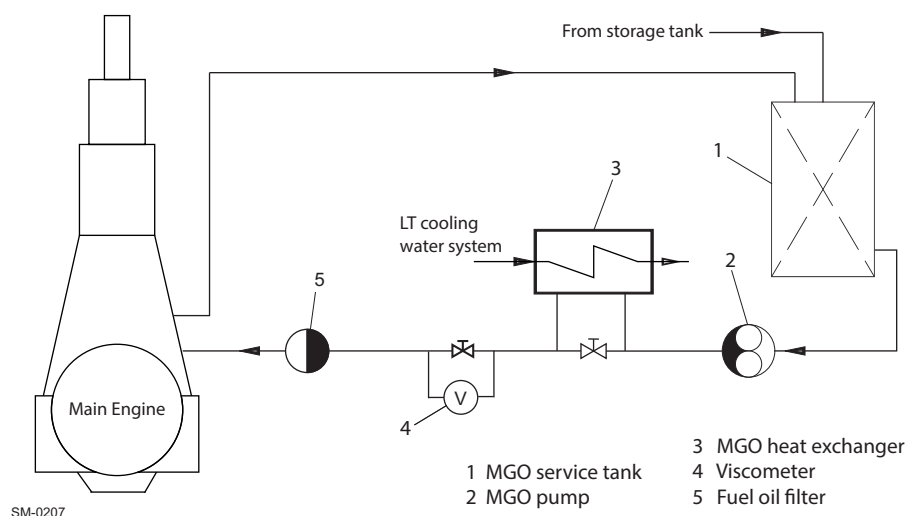

Figure 4-51 Pilot fuel oil system

On-engine pilot fuel oil system

The on-engine pilot fuel pump unit raises the pilot diesel oil pressure to the required level. The unit consists of an electrically-driven radial piston pump (with built-in overpressure bypass valve), fuel filters, and a pressure control valve.

Main components of pilot fuel oil system

The main components of the pilot fuel oil system are the pump unit, common rail pipe, feed pipes, and injection valves.

Pressurised pilot fuel is delivered from the pump unit into a common rail pipe. The high-pressure piping from pump to injectors is of double-wall type. Any leakage is collected from the annular space of the double-wall pipe and led to a collector fitted with a leakage sensor. The common rail piping delivers pilot fuel to each injection valve and in addition acts as a pressure accumulator against pressure pulses.

Pilot injection valves and pre-chambers

The X-DF engine uses pilot injectors with built-in solenoid valves. The injectors are electronically controlled by the WinGD Engine Control System, which allows exact timing and duration of the injection. To have the best ignition and combustion stability, the pilot injection valves are combined with pre-chambers. These pre-chambers are directly cooled by the HT cooling water from the cylinder cover. Furthermore the injectors are cooled by system oil.

Pilot fuel injection is also activated in diesel mode operation to prevent excessive deposit formation on the injector tips and in the pre-chambers.

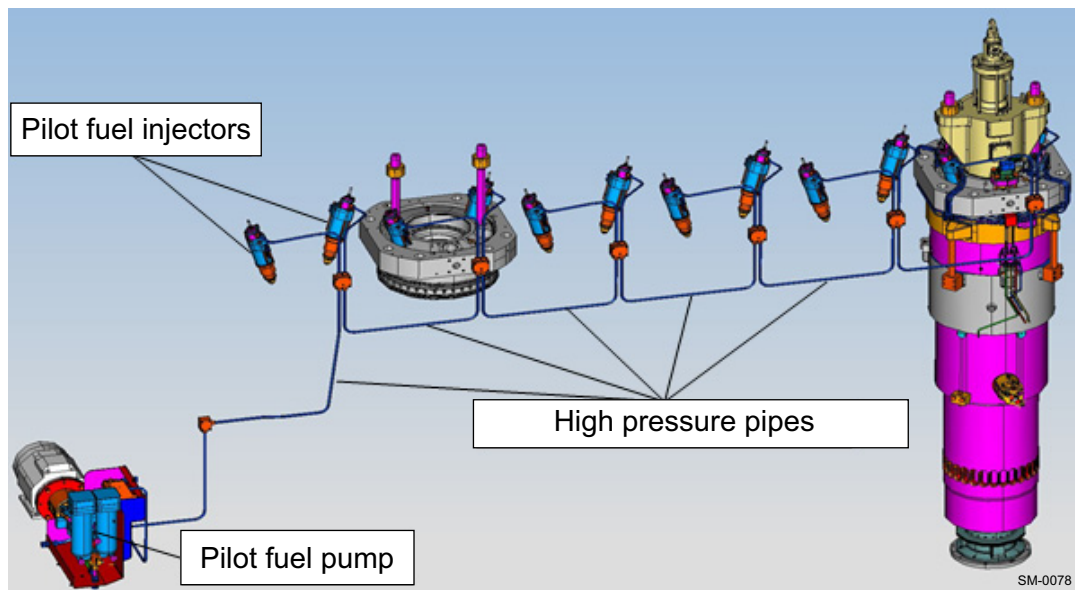

Figure 4-52 Pilot fuel high-pressure system

Pilot fuel oil filter

A 10 µm filter is provided in the engine's pilot fuel unit. On the system side, a 10 µm (absolute sphere passing mesh size) duplex filter as specified in [Table 4-11](#) must be installed. For the installation position see [MIDS](#).

Table 4-11 Specification of the pilot fuel oil filter on the system side

Type	Duplex filter
Working viscosity	2-17 cSt required for MDO/MGO
Flow rate	According to GTD . The capacities cover the needs of the engine only. If a filter of automatic back-flushing type is installed, the feed and booster pump capacities must be increased by the quantity needed for back-flushing of the filter.
Service pressure	Max. 10 bar at filter inlet
Test pressure	Specified by classification society
Permitted differential pressure at 14 cSt	<ul style="list-style-type: none"> — clean filter: max. 0.2 bar — dirty filter: max. 0.6 bar — alarm setting: max. 0.8 bar Note: Real operational settings could be less according to filter maker's recommendation.
Minimum bursting pressure of filter insert	Max. 3 bar differential across filter
Filter insert mesh size	Specified max. 10 µm abs.
Filter insert material	Stainless steel mesh (CrNiMo)
Working temperature	Up to 50 °C

4.7 Fuel oil system



The latest version of the **Marine Installation Drawing Set** relevant for the fuel oil system (DG 9723) is provided on the WinGD webpage under the following link:

[MIDS](#)

Figure 4-53 shows the installation principle for maximum fuel flexibility.

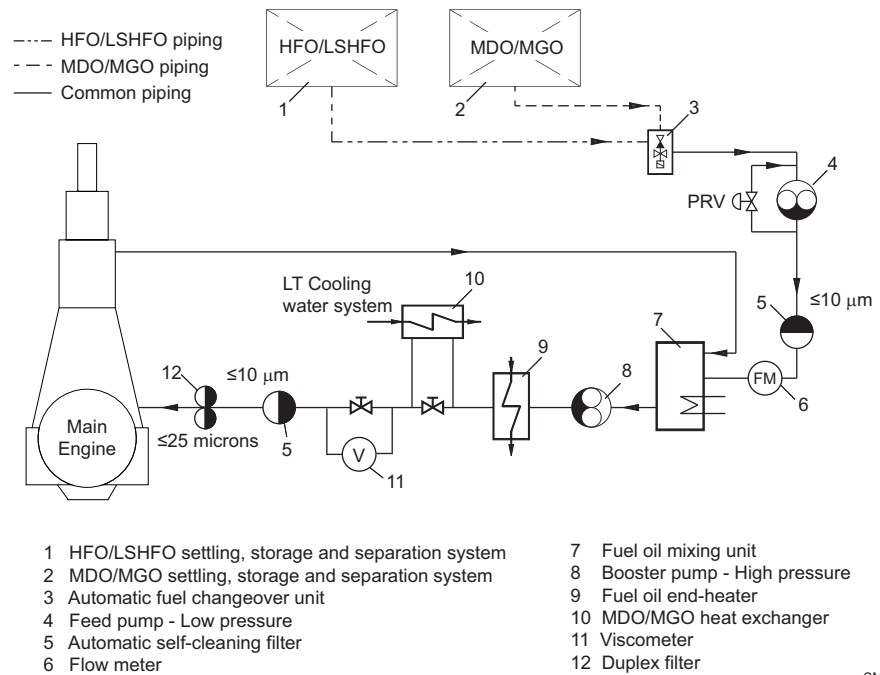

Figure 4-53 Fuel oil system



Further information about MDO/MGO fuels is available in the separate **Concept Guidance** (DG 9723). This considers additional design options for the fuel oil system, as well as optional heat exchangers for better viscosity regulation when changing between HFO/LSHFO and MDO/MGO.

This is provided on the WinGD webpage under the following link:

[Concept Guidance Distillate Fuels](#)

Fuel consumption

Data of fuel consumption should be taken from the project-specific *GTD* data sheet.

4.7.1 Fuel oil system components

The following components are associated with a fuel oil system of maximum fuel flexibility, i.e. operation on heavy fuel oils and distillates, as indicated in Figure 4-53. Therefore, the following section considers a fuel oil viscosity of 700cSt at 50°C.

In cases where only distillate fuels are considered, the system can be simplified (as explained in section 4.7.2, 4-97), however consideration must be given the reduction in fuel oil viscosity.

Feed pump — Low-pressure fuel oil

Type	Positive displacement screw pump with built-in safety valve
Capacity	According to <i>GTD</i> : The capacity is to be within a tolerance of 0 to +20 % of the GTD value, plus back-flushing flow of automatic self-cleaning filter, if such filter is installed.
Delivery pressure	The feed pump must provide a required pressure in the downstream mixing unit to prevent water in the system from vaporising into steam. The pump, whilst considering system pressure drop, must provide a minimum of 1 bar above the water vapour pressure and always be above a 3 bar value. The water vapour pressure is a result of the system temperature and pressure for a given fuel type. Heavier oils need more heat and higher temperatures to maintain them at the correct viscosity compared to lighter oils. (Refer to the formula and example below.)
Electric motor	The electric motor driving the fuel oil feed pump must be sized for the maximum pressure head (difference between inlet and outlet pressure), maximum fuel oil viscosity (100 cSt), and the maximum required flow.
Working temp.	Below 100 °C
Fuel oil viscosity	Depending on the fuel oil system's heat control, viscosity at working temperature will often differ. It will not be more than 100 cSt, however can be considerably less (as low as 2 cSt with lower viscosity fuel like MDO/MGO or possibly LSHFO, see viscosity-temperature diagram - Figure 4-59 , 4-102). The manufacturer's specification must comply with the fuel viscosity range. For system options with additional temperature regulation, see Concept Guidance Distillate Fuels .

Formula for delivery gauge pressure

$$p_v + 1 + \Delta p_1 + \Delta p_2 \text{ [bar]}$$

where:

p_v = water vapour gauge pressure at the required system temp. [bar]
(see viscosity-temperature diagram in section [4.7.7](#), [4-102](#))

Δp_1 = max. pressure losses between feed pumps and mixing unit [bar]

Δp_2 = max. pressure change difference across the pressure regulating valve of the feed system between min. and max. flow
(see [Pressure regulating valve](#), [4-87](#))

Example HFO of 700 cSt at 50 °C, required system temperature 145 °C:

p_v = 3.2 bar

Δp_1 = 0.5 bar

Δp_2 = 0.6 bar

Delivery gauge pressure = 3.2 + 1 + 0.5 + 0.6 = 5.3 bar

Pressure regulating valve

The pressure regulating valve returns the excess fuel oil that is not required by the main engine, recirculating more when the engine is at lower power. To avoid heating-up of the fuel by recirculation, the return pipe is designed with cooling ribs.

It also works to ensure that the pressure downstream of the low-pressure feed pump remains 1 bar above the evaporation pressure of the water and there prevents entrained water within the fuel oil system from flashing off into steam.

The pressure regulating valve should have a flat steady-state characteristic across the fuel oil recirculation flow range.

Type	Self-operated or pilot-operated, with a manual emergency control. Either direct hydraulically or pneumatically actuated. However, when using a pneumatically actuated valve, use a combined spring type to close the valve in case of air supply failure.
Maximum capacity	According to <i>GTD</i> : Refer to feed pump capacity.
Minimum capacity	Approx. 20% of that of the fuel oil feed pump
Service pressure	Max. 10 bar
Pressure setting range	2-6 bar
Inlet pressure change	The inlet pressure may vary by up to 0.8bar depending on the flow in the range of 20% to 100%.
Working temperature	Below 100 °C
Fuel oil viscosity	Depending on the fuel oil system's heat control, viscosity at working temperature will often differ. It will not be more than 100cSt, however can be considerably less (as low as 2cSt with lower viscosity fuel like MDO/MGO or possibly LSHFO, see viscosity-temperature diagram - Figure 4-59 , 4-102). The manufacturer's specification must comply with the fuel viscosity range. For system options with additional temperature regulation, see Concept Guidance Distillate Fuels .

Mixing unit

The mixing unit equalises the temperature between the hotter fuel oil returning from the engine and the colder fuel oil from the service tank. The temperature difference between these sources is particularly high when changing over from HFO to MDO/MGO and vice versa.

Due to the small amount of fuel consumed, especially in part-load operation, only a small mixing unit is required. It is recommended that the tank contains no more than approx. 100 litres. This is to avoid the changeover from HFO to MDO/MGO or vice versa taking too long.



For changing over between heavy fuel oil and marine diesel oil (MDO/MGO) and vice versa, as well as for operation on distillate fuel, refer to the separate **Concept Guidance** (DG 9723), which is provided on the WinGD webpage under the following link:

[Concept Guidance Distillate Fuels](#)

Type	Cylindrical steel fabricated pressure vessel as shown in Figure 4-54
Capacity	Refer to <i>GTD</i> .
Dimensions	See <i>MIDS</i> .
Service pressure	10bar
Test pressure	According to classification society
Working temperature	Up to 150 °C

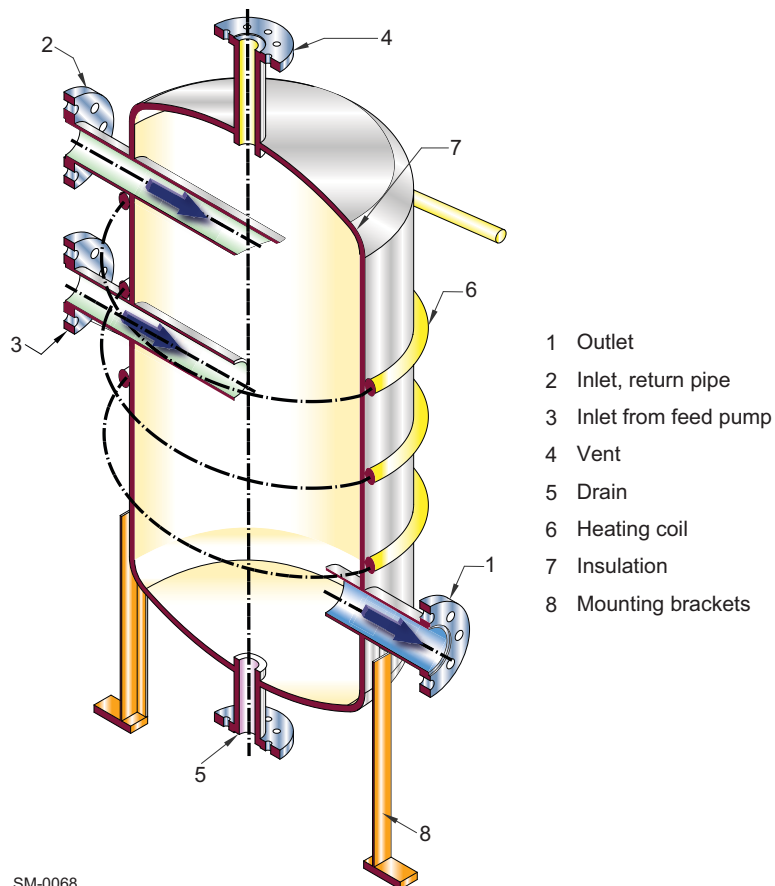

SM-0068

Figure 4-54 Mixing unit

Booster pump — High-pressure fuel oil

The fuel oil booster pump delivers the fuel to the engine via a fuel oil end-heater for HFO operation.

Type	Positive displacement screw pump with built-in safety valve
Capacity	According to <i>GTD</i> : The flow rate is to be within a tolerance of 0 to +20% of the GTD value, plus back-flushing flow of automatic self-cleaning filter, if such filter is installed.
Inlet pressure	Up to 6 bar
Delivery head	Final delivery pressure according to actual piping layout. Refer to <i>GTD</i> .
Electric motor	The electric motor driving the HP booster pump must be sized large enough for the power absorbed by the pump at maximum pressure head (difference between inlet and outlet pressure), maximum fuel oil viscosity (70 cSt), and the required flow.
Working temperature	Up to 150 °C

End-heater

Operation is regulated with either the temperature or the viscosity (default mode) of the fuel oil. The viscosity is measured by the viscometer.

Type	Tubular or plate type heat exchanger, suitable for heavy oils up to 700 cSt at 50 °C (or as project is defined)
Heating source	Steam, electricity, or thermal oil
Consumption of saturated steam	At 7 bar gauge pressure [kg/h]: $1.32 \cdot 10^{-6} \cdot CMCR \cdot BSFC \cdot (T_1 - T_2)$ where: — <i>BSFC</i> = brake specific fuel consumption at contracted maximum continuous rating (<i>CMCR</i>) — T_1 = temperature of fuel oil at viscometer ^{a)} — T_2 = temperature of fuel oil from service tank
Heating capacity [kW]	$0.75 \cdot 10^{-6} \cdot CMCR \cdot BSFC \cdot (T_1 - T_2)$
Working pressure	Max. 12 bar, pulsating on fuel oil side
Working temperature	Up to 150 °C, outlet temperature on fuel oil side

a) The viscosity is maintained by regulating the fuel temperature after the end-heater.

Viscometer

The viscometer regulates the fuel oil end-heater, enabling the fuel oil viscosity to be kept at preferable engine conditions. When using HFO/LSHFO the ideal is 13-17cSt, and between 10-20cSt is acceptable. Although there is no active cooling required to keep the minimum limit of 10cSt, the absolute minimum viscosity is 2 cSt.

When using low-viscosity fuels, the end-heater must not be active and the MDO/MGO heat exchangers will be required to maintain these limits.

MDO/MGO heat exchanger

For MDO/MGO operation, the fuel might need to be cooled to stay above a minimum viscosity of 2 cSt at engine inlet. This fuel oil heat exchanger (and any optional heat exchanger that is included, as shown in *Concept Guidance Distillate Fuels*) uses low-temperature cooling water.

A chiller unit (cooling from refrigeration) is not required if the fuel properties are in line with the latest ISO 8217:2017 specification. Such a unit would only be needed for off-spec fuels that are not supported by WinGD.

Type	Tubular or plate type heat exchanger, suitable for diesel oils
Cooling medium	LT cooling water Alternatively: glycol-water mixture delivered from chiller unit
Cooling capacity [kW]	$Q = \frac{0.34 \cdot BSFC \cdot P \cdot (T_1 - T_2 + 25.65)}{10^6}$ <p>where:</p> <ul style="list-style-type: none"> Q [kW] = cooler heat dissipation at 100% engine load BSFC [g/kWh] = specific fuel consumption at design conditions and 100% engine load P [kW] = engine power at 100% CMCR T₁ [°C] = temp. of distillate fuel supplied to engine T₂ [°C] = temp. of distillate fuel required at engine inlet
Working pressure	Max. 12bar, pulsating on fuel oil side

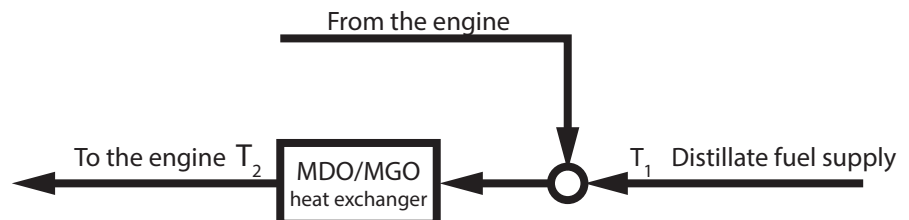

SM-0187

*Fuel oil filters — Arrangement 'A'***Filtration grading**

The grade of filter mesh is relative to the size of particles it captures, however, there are different ratings for filtration efficiencies and the rating parameters vary among manufacturers.

For simplicity, it is assumed that particles are spherical, therefore the size is defined by an equivalent diameter. A filter's grading size is associated with this equivalent diameter but can vary depending on whether an *absolute* or *nominal* grading system is used.

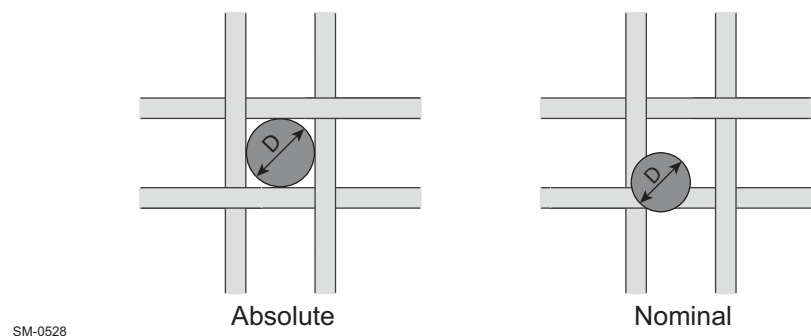

Figure 4-55 Mesh size difference between absolute and nominal

Absolute Filtration Grade

This value indicates the largest equivalent diameter capable of passing through the filter. This value equals the size of the mesh coarseness and can therefore be referred to as the *absolute sphere passing mesh size*. Approximately all particles larger than the specified size will be trapped on or within the filter.

Nominal Filtration Grade

This value is typically smaller than the absolute value and refers to an equivalent diameter where most particles will be trapped. Generally, this is interpreted as a 85% to 90% filtration for particles larger than the nominal value but this can range (from 60% to 90% approximately). Because of the complication this variation can cause, the nominal grade for filtration is not used in the following.

NOTE

WinGD provides all filter mesh sizes in absolute (abs.) values.

Arrangement 'A' of fuel oil filters (see [Figure 4-56](#), [4-92](#)) comprises:

- An automatic self-cleaning filter of maximum 10 μm abs., installed either in the 'cold' feed system (see [Option 1](#), [4-93](#)) or in the 'hot' booster system close to engine inlet (see [Option 2](#), [4-94](#)).
- A duplex filter of recommended maximum 25 μm abs., installed downstream of the engine inlet booster system (see [Duplex filter](#), [4-95](#)).

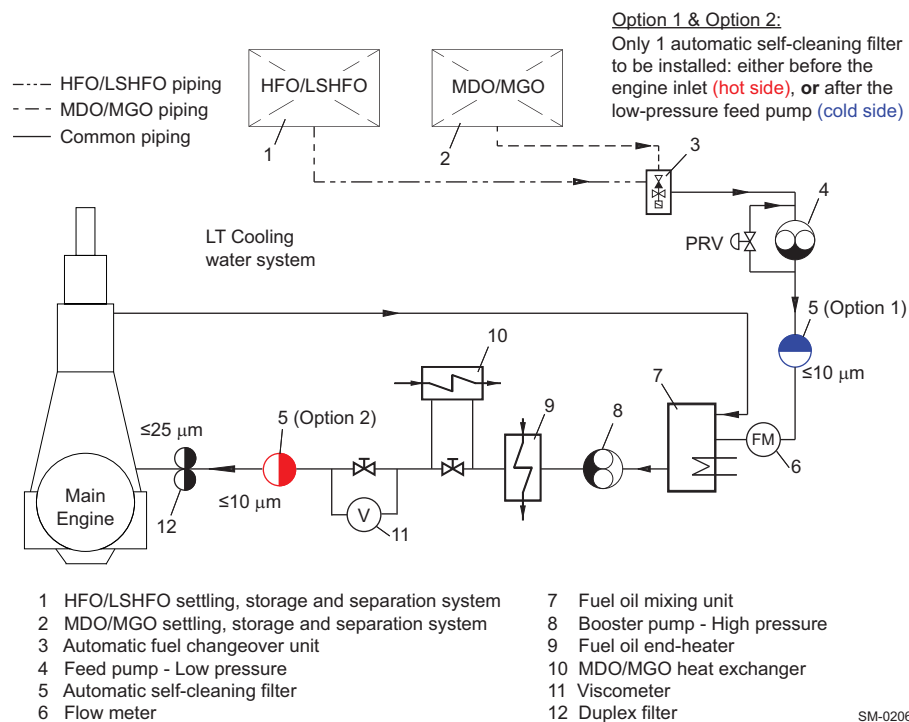

Figure 4-56 Fuel oil filter arrangement 'A'

The automatic self-cleaning filter of maximum 10µm abs. is used to protect the engine against serious damage. It captures the catalytic fines which were not removed by the fuel oil separator. In addition, the filter provides a good indication of the separator's efficiency.

NOTE The self-cleaning performance must be suitable for the required filter fineness.

The 10µm abs. filter can be installed in two different locations:

Option 1

Filter installation in the feed system:

In this position the maximum 10µm abs. filter can be designed for a lower flow rate compared to the installation in the booster system. However, higher resistance due to higher fuel viscosity needs to be considered.

Advantage and disadvantage of this filter position:

Advantage	Booster pump is protected against abrasive catfines
Disadvantage	Engine is not optimally protected against booster pump wear particles

Table 4-12 Specification of automatic self-cleaning filter in feed system

Working viscosity	100cSt, for HFO of 700cSt at 50°C
Flow rate	According to <i>GTD</i> . The capacities cover the needs of the engine only. The feed pump capacity must be increased by the quantity needed for back-flushing of the filter.
Service pressure after feed pumps	10 bar at filter inlet
Test pressure	Specified by classification society
Permitted differential press. at 100cSt	<ul style="list-style-type: none"> — clean filter: max. 0.2 bar — dirty filter: max. 0.6 bar — alarm setting: max. 0.8 bar Note: Real operational settings could be less according to filter maker's recommendation.
Minimum bursting press. of filter insert	Max. 3 bar differential across filter
Mesh size	Max. 10 µm abs.
Mesh size bypass filter	Max. 25 µm abs.
Filter insert material	Stainless steel mesh (CrNiMo)

Option 2 Filter installation in the booster circuit:
The maximum 10 µm abs. filter is installed in the booster circuit close to engine inlet. The filter needs to be laid out for a maximum working temperature of 150°C.

Advantage and disadvantage of this filter position:

Advantage	Optimum engine protection from fuel oil catfines and other abrasive particles from system wear
Disadvantage	Booster pump is not ideally protected against catfines

Table 4-13 Specification of automatic self-cleaning filter in booster system

Working viscosity	10-20 cSt required for HFO (13-17 cSt recommended)
Flow rate	According to <i>GTD</i> . The capacities cover the needs of the engine only. If a filter of automatic back-flushing type is installed, the feed and booster pump capacities must be increased by the quantity needed for back-flushing of the filter.
Service pressure	Max. 12 bar at filter inlet
Test pressure	Specified by classification society
Permitted differential press. at 17 and 20 cSt	<ul style="list-style-type: none"> — clean filter: max. 0.2 bar — dirty filter: max. 0.6 bar — alarm setting: max. 0.8 bar Note: Real operational settings could be less according to filter maker's recommendation.
Minimum bursting press. of filter insert	Max. 3 bar differential across filter
Mesh size	Max. 10 µm abs.
Mesh size bypass filter	Max. 25 µm abs.
Filter insert material	Stainless steel mesh (CrNiMo)
Working temperature	Up to 150 °C

Duplex filter The second filter in Arrangement 'A' is a duplex filter of recommended maximum 25 µm abs. A coarser filter is also acceptable. The duplex filter is of manual cleaning type and is installed in the booster system close to engine inlet. This filter type is sufficient as most particles are already removed by the 10 µm filter as outlined in [Option 1](#), [4-93](#) and [Option 2](#), [4-94](#).

Table 4-14 Specification of duplex filter in booster system

Working viscosity	10-20 cSt required for HFO (13-17 cSt recommended)
Flow rate	According to GTD . The capacities cover the needs of the engine only. If a filter of automatic back-flushing type is installed, the feed and booster pump capacities must be increased by the quantity needed for back-flushing of the filter.
Service pressure	Max. 12 bar at filter inlet
Test pressure	Specified by classification society
Permitted differential press. at 17 and 20 cSt	<ul style="list-style-type: none"> — clean filter: max. 0.2 bar — dirty filter: max. 0.6 bar — alarm setting: max. 0.8 bar Note: Real operational settings could be less according to filter maker's recommendation.
Minimum bursting press. of filter insert	Max. 3 bar differential across filter
Mesh size	Max. 25 µm abs.
Filter insert material	Stainless steel mesh (CrNiMo)
Working temperature	Up to 150 °C

Fuel oil filter — Arrangement ‘B’

A maximum 10 µm abs. filter of automatic self-cleaning type is installed in the 'hot' booster system close to engine inlet. The filter needs to be laid out for a maximum working temperature of 150°C.

NOTE The self-cleaning performance must be suitable for the required filter fineness.

Same filter specification as provided by Table 4-13, 4-94.

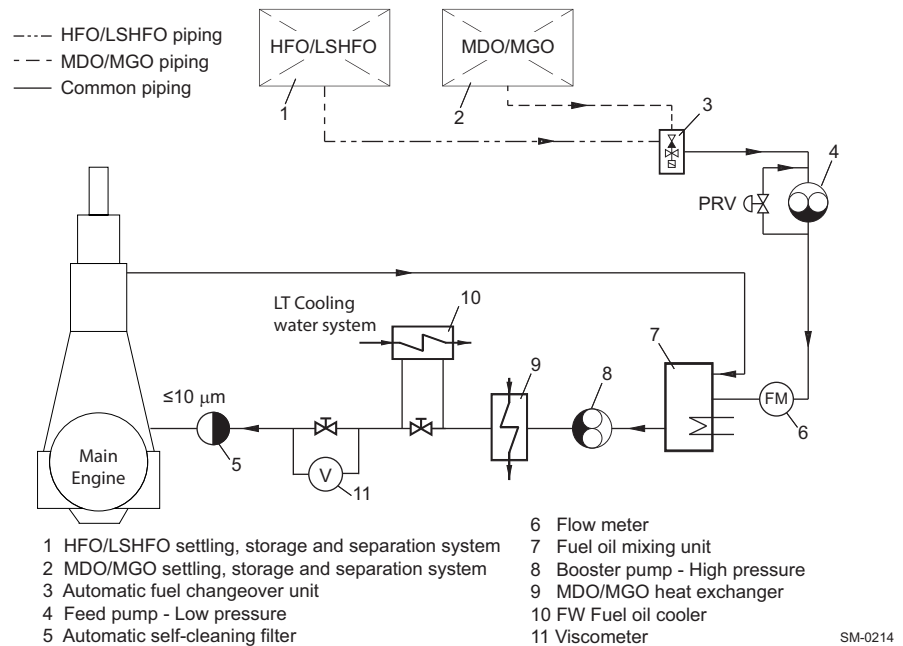

Figure 4-57 Fuel oil filter arrangement ‘B’

Arrangement ‘B’ does not include secondary duplex filtration. It lacks the indication of overall performance of the fuel oil treatment system and gives no indication when the automatic self-cleaning filter fails.

NOTE WinGD recommends Arrangement ‘A’, as this is a best practice solution.

4.7.2 Fuel oil system with only MDO/MGO or MGO

If the main engine is designed for only MDO/MGO or MGO fuel oil, the system may be simplified in comparison to the conventional system specified in section 4.7.1, 4-85.

The changes are as follows:

- The fuel oil mixing unit is omitted.
- The fuel oil end-heater is omitted, along with the associated viscometer and control logic.
- The simplified fuel oil filter arrangement like that in arrangement 'B' is applied.

Additional optional changes:

- The feed pump and booster pump can be replaced with a single delivery pump. If this option is selected, the pump must be located in the recirculation piping and must not be too high relative to the fuel oil tanks (see $(\delta)H$ in Figure 4-58). This must be in accordance with manufacturer's specification.

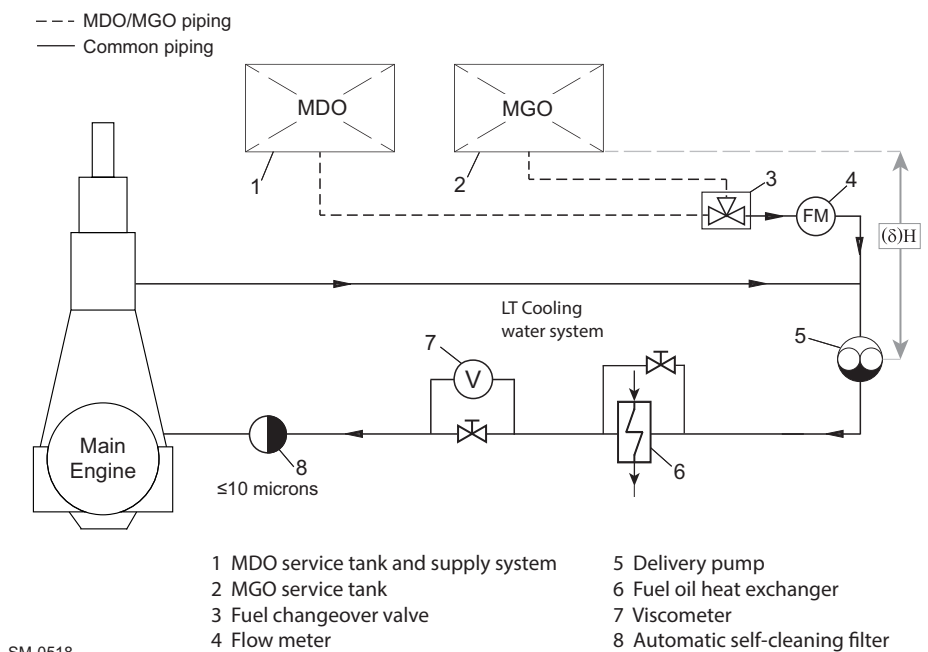

Figure 4-58 Fuel oil system — Arrangement with only MDO/MGO or MGO

Fuel oil feed pump

To correctly deliver the fuel oil to the engine, the fuel oil service tank arrangement must provide the required inlet pressure for the fuel oil feed pump, as defined by the supplier.

Type	Positive displacement screw pump with built-in safety valve
Capacity	According to <i>GTD</i> , with a tolerance of 0 to +20% of the GTD value.
Inlet pressure	As defined by the supplier
Delivery head	Ensure an engine inlet pressure of 10 bar(g) at main engine stop condition, with consideration of pressure loss over piping and static height — Refer to <i>GTD</i> .
Working temperature	Up to 60 °C

Fuel oil heat exchanger

The standard proposal for MDO and MGO (compliant to ISO 8217:2017) is a heat exchanger without temperature or flow control. The viscosity of the MDO and MGO will be kept within the acceptable range for engine operation if the fuels are cooled by freshwater from the central cooling system (with temperatures between 25 and 36 °C). A chiller unit (cooling from refrigeration) may be needed for off-spec fuels that are not supported by WinGD.

Fuel oil filter

An automatic self-cleaning filter with a maximum of 10 µm mesh size must be installed close to engine inlet, as indicated in [Figure 4-58](#), [4-97](#). The working temperature is up to 60 °C.

4.7.3 Flushing the fuel oil system



For flushing of the fuel oil system refer to the latest version of the relevant **Instruction** (DG 9723), which is provided on the WinGD webpage under the following link:

[*Instruction for flushing - Fuel oil system*](#)

4.7.4 Fuel oil treatment



The latest version of the **Concept Guidance** for fuel oil treatment (DG 9723) is provided on the WinGD webpage under the following link:

[Fuel oil treatment](#)

Settling tanks

Gravitational settling of water and sediment from modern heavy fuel oils is an extremely slow process due to the small difference in densities. The time required for the settling to occur depends on the depth of the tank, as well as on the viscosity, temperature and density difference. Tanks that are shallower with a wider diameter enable better separation than thinner, taller tanks.

Further design features consider a level monitoring device and remote closing discharge valves to the separator(s) and engine systems, a connection to an overflow tank, and a self-closing cock just above the bottom of the tank for removal of the sludge and water.

Service tanks

Most of the service tank design features are similar to the settling tanks, however, there is no direct connection to the overflow tank. Instead a recirculating line, with an inlet just above the bottom of the service tank, leads back to the settling tanks.

Diesel oil service tanks are similar to heavy oil service tanks, with the possible exception of tank heating, although this may be incorporated for vessels constantly trading in cold climates.

Water in fuel

Due to condensation or heating coil leakage, water may be present in the fuel after the separators. This can be manually removed by a self-closing cock. In addition, the recirculation connection close to the bottom of the tank ensures that contaminated fuel is recirculated to the settling tank.

Cleaning of fuel

The fuel is cleaned from the settling tank to the service tank. Ideally, when the main engine is operating at CMCR, the fuel oil separator(s) should be able to maintain a continual overflow from the service tank to the settling tank. The cock, used to remove sludge and water, is to be operated at regular intervals to observe the presence of water, a significant indication for the condition of the separator(s) and heating coils.

Centrifugal fuel oil separators

There are two types of oil separators:

- Type 1 — Separators with gravity discs
- Type 2 — Separators without gravity discs

NOTE

Separators with gravity discs represent outdated technology and are therefore not supported by WinGD.

Separators without gravity discs

These separators are self-adjusting to the fuel properties and self-cleaning. Separators without gravity discs operate as combined purifiers-clarifiers; thus water and sediment separation is integrated in one unit. The manufacturers claim extended periods between overhaul. Compared to the outdated separators with gravity discs, the reliability is greatly improved, enabling unattended onboard operation. As it is usual to install a standby separator as a back-up, it is of advantage to use both units in parallel to improve the separation result.

For further details and information regarding the separators please refer to the manufacturer's instructions.

Separation efficiency

The separation efficiency is a measure of the separator's capability to remove specified test particles. The separation efficiency is defined as follows:

$$n = 100 \cdot \left(1 - \frac{C_{out}}{C_{in}} \right)$$

where:

- n = separation efficiency [%]
- C_{out} = number of test particles in cleaned test oil
- C_{in} = number of test particles in test oil before separator

Certified Flow Rate

To express the performance of separators according to a common standard, the term Certified Flow Rate (CFR) has been introduced. CFR is defined as the flow rate in litres/hour, 30 minutes after sludge discharge, at which the separation efficiency is 85 % when using defined test oils and test particles. CFR is defined for equivalent fuel oil viscosities of 380 and 700 cSt at 50°C.

More information can be found in the CEN document CWA 15375:2005 (E) of the European Committee for Standardization.

Throughput capacity

The required minimum effective throughput capacity (litres/hour) of the separators is determined by the formula $1.2 \cdot CMCR \cdot BSFC \cdot 10^{-3}$ [litres/hour] as shown in the example below. The project-specific BSFC value at 100% CMCR power output must be taken from the *GTD*. The nominal separator capacity and the installation are to comply with the recommendations of the separator manufacturer.

The MDO separator capacity can be estimated using the same formula.

Example

- 9-cyl. engine
- CMCR(R1 selected): 38,880 kW
- BSFC: 177.2 g/kWh
- **Throughput:** $1.2 \cdot 38,880 \cdot 177.2 \cdot 10^{-3} = 8,267$ litres/hour

Fuel oil samples

To ensure that representative samples of fuel oil can be taken, dedicated sampling points (cocks) are provided on engine side. Such cocks need also to be installed on system side according to the relevant system proposal drawing in *MIDS*.

4.7.5 Pressurised fuel oil system

The fuel is supplied from the heated heavy fuel oil service tank or the unheated diesel oil service tank to the low-pressure feed system.

Fuel changeover

For changing over from one fuel type to the other it was common to have a simple, manually operated three-way valve. This arrangement is not recommended any longer, as with the introduction of different Emission Control Areas (ECA), fuel changeover is quite frequently required, even at high engine load. In the past it was needed in rare cases only, for instance due to maintenance or before stopping the engine, i.e. at relatively low loads.

Automatic changeover unit

Consequently, a well proven automatic changeover unit is nowadays recommended, which ensures:

- A maximum temperature gradient of 2K/min during changeover
- A maximum viscosity of 20cSt
- A minimum viscosity of 2cSt; this minimum limit is most challenging during changeover from HFO to distillate fuel.
Attention: Not all changeover units guarantee keeping the minimum viscosity limit, as viscosity is not controlled.
- A best-practice automatic control of diesel oil cooler activation

4.7.6 Fuel oil specification



The validated fuel oil qualities are published in the document **Diesel engine fuels** provided on the WinGD webpage under the following link:

[*Diesel engine fuels*](#)

4.7.7 Fuel oil viscosity-temperature dependency

The fuel oil viscosity depends on its temperature. This dependency is shown as graph in Figure 4-59.

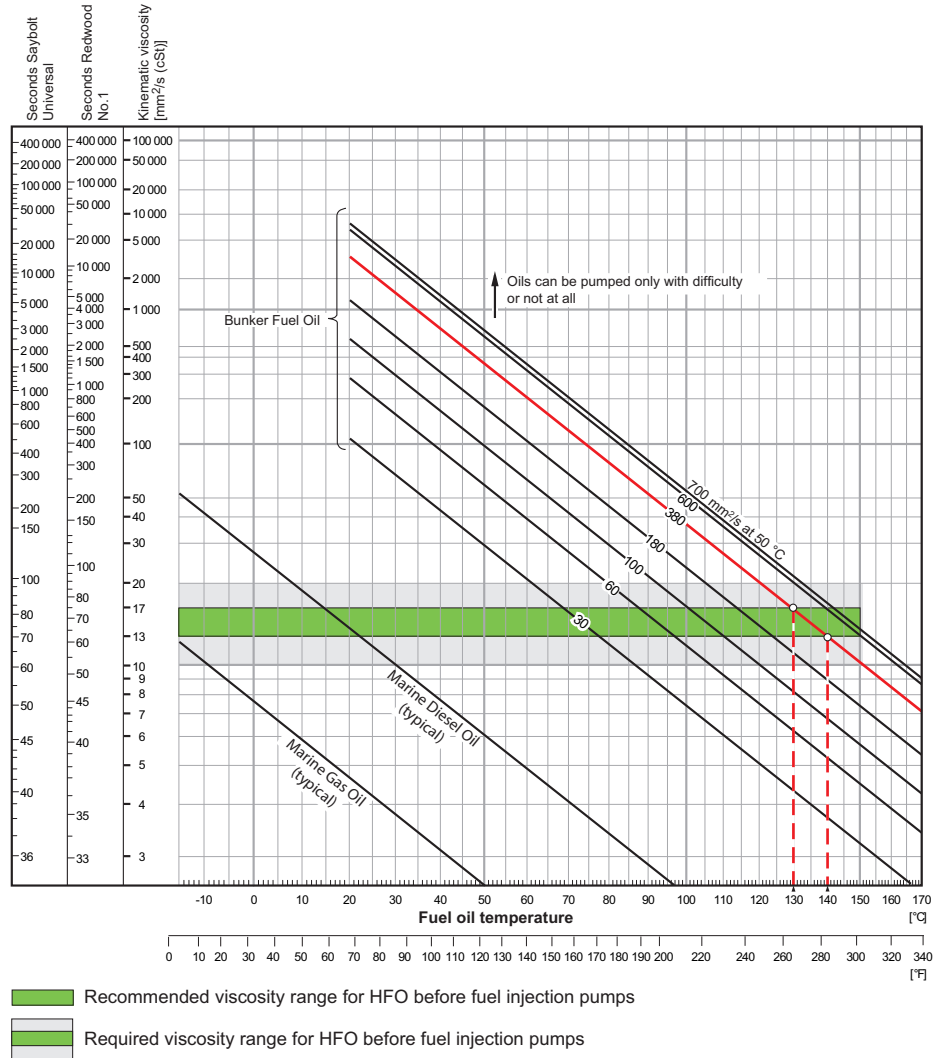

Example To obtain the recommended viscosity before fuel injection pumps a fuel oil of 380 mm²/s (cSt) at 50 °C must be heated up to 130 °C to 140 °C.

SM-0215

Figure 4-59 Fuel oil viscosity-temperature diagram

4.8 Air supply system



The latest version of the **Marine Installation Drawing Set** relevant for the air supply system (DG 9725) is provided on the WinGD webpage under the following link:

[MIDS](#)

Compressed air is required for engine starting and control, exhaust valve air springs, the washing plant for the scavenge air coolers, and general services.

The starting and control air system shown in [Figure 4-60](#) comprises two air compressors, two air receivers, and systems of pipework and valves connected to the engine starting air manifold.

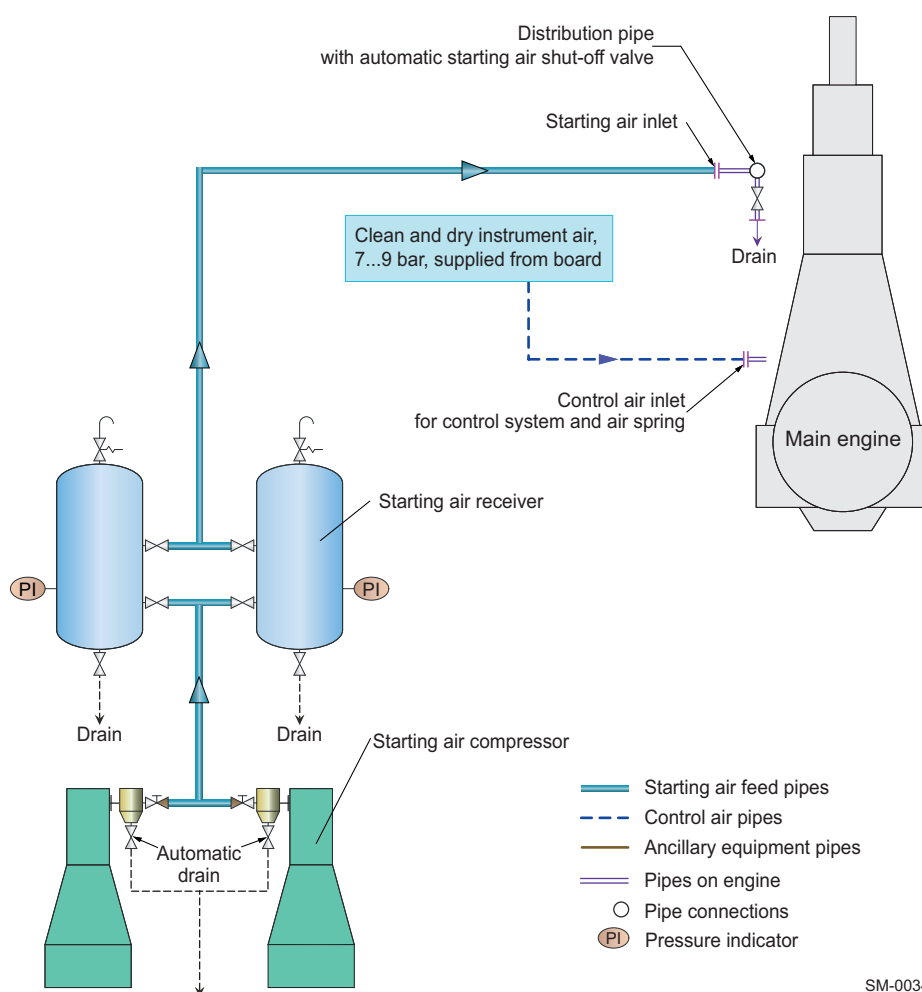

SM-0034

Figure 4-60 Air supply system

4.8.1 Capacities of air compressor and receiver

The capacity of the air compressor and receiver depends on the total inertia (J_{tot}) of the propulsion system's rotating parts.

- Total inertia = engine inertia + shafting and propeller inertia¹⁾:

$$J_{tot} = J_{eng} + J_{S+P}$$

- Engine inertia (J_{eng}): refer to *GTD*²⁾

- Relative inertia:

$$J_{rel} = \frac{J_{tot}}{J_{eng}}$$

4.8.2 System specification

Starting air compressors

Capacity	Refer to <i>GTD</i> .
Delivery gauge pressure	25 or 30 bar

The discharge air temperature must not exceed 90°C and the air supply to the compressors is to be as clean as possible without oil vapour.

Starting air receivers

Type	Fabricated steel pressure vessels with domed ends and integrated pipe fittings for isolating valves, automatic drain valves, pressure reading instruments and safety valves
Capacity	Refer to <i>GTD</i> .
Working gauge pressure	25 or 30 bar

1) Propeller inertia includes the part of entrained water.

2) The *GTD* application enables the capacities of compressors and air receivers to be optimised for the inertia of the engine and shaft line.

4.8.3 Control air

Control air supply system

Control air is supplied from the board instrument air supply system (see [Figure 4-60](#), [4-103](#)) providing air at 8bar gauge pressure (within a range of 7.0-9.0bar). The air quality should comply with the compressed air purity class 5-4-3 according to ISO 8573-1 (2010-04-15).

Control air consumption

The required control air flow capacities are shown in [Table 4-15](#). These data can be used for sizing the relevant engine external piping and facilities.

Table 4-15 Control air flow capacities

No. of cyl.	Control air flow capacity [Nm ³ /h]
6	14.4
7	16.8
8	19.2
9	21.6

4.8.4 Service and working air

Service and working air for driving air powered tools and assisting in the cleaning of the scavenge air coolers is also provided by the board instrument air supply system.

4.9 Leakage collection system and washing devices



The latest version of the **Marine Installation Drawing Set** relevant for the leakage collection and washing system (DG 9724) is provided on the WinGD webpage under the following link:

[MIDS](#)

4.9.1 Sludge oil trap solutions

General description of the sludge oil trap

General description

A sludge oil trap is used to collect cylinder oil residue, product of combustion, and leaky system oil from the gland box. When the main engine is running, oil residue in the piston underside is collected from the cylinder lubrication as it is being scraped down from the cylinder liners. This oil is removed through the drains of each piston underside unit area and collected into the designated sludge oil trap. The sludge oil trap is connected with the scavenge air receiver, therefore the sludge oil trap is classified as a pressure tank, and in principle it requires approval and certification by the classification society. On the main engine side, the maximum scavenge air pressure in the scavenge air receiver is approximately 3.5-4.0 bar(g). Therefore, the tank pressure must be designed and produced accordingly.

Installation requirements

It is recommended to install the sludge oil trap as close as possible to the main engine. The drain pipe must have a minimum slope of 15° as the sludge tends to stick which could cause a blocking of the drain pipe. It is advised to install heat tracing and insulation around the drain pipe to keep the sludge in a liquid state. A heating coil must also be installed in the sludge oil trap. The heating system in the sludge oil trap must be designed to keep the sludge at approximately 50 to 60°C. The sludge oil trap design must follow the fire extinguishing requirements in case of a fire in the scavenge air receiver. For these reasons, a manual shut-off valve must be installed between the piston underside drain and the sludge oil trap.

In view of the current issues with the sludge oil trap design and based on the feedback from shipyards and shipowners, WinGD has provided an overview of the advantages and disadvantages of different solutions. A summary of these different systems and design options for shipyards and design institutes is provided below.

Solution 1: A constantly-drained sludge oil trap with separate sludge accumulation

Solution 1 description

The main function of this system is to reduce the pressure of the sludge emulsion from scavenge air pressure to just above atmospheric pressure, as well as to separate the solids from the liquids in the sludge emulsion.

Reducing the pressure prevents the sludge oil tank from becoming pressurised. This is accomplished by the orifice being fitted onto the drain outlet pipe. To ensure a continuous drain flow, some scavenge air flows to the sludge oil trap. The scavenge air is mainly released on the top of the sludge oil trap by passing through an orifice to the venting pipe. At the same time, an additional small amount is directed by an overflow pipe and through another orifice to the sludge oil tank. This continuous drain flow ensures that the drain pipe will not block and it will result in a scavenge air loss. The scavenge air loss is especially advantageous compared to the other possible solutions that are described and will not have any negative impact on the engine performance.

Separating the solids from the liquids will significantly reduce the risk of solid particles causing the orifice to become blocked. The sludge oil trap collects the solids from the bottom of the piston underside area. These solids settle at the bottom of the sludge oil trap. At the same time, the liquid part is drained by an overflow pipe (which is equipped with an orifice) to the sludge oil tank. As the solids are separated and since the overflow pipe is located at the upper part of the sludge oil trap, the risk of blocking the orifice by solid particles is significantly reduced. A sufficiently large opening near the bottom of the sludge oil trap is necessary to be able to remove the rather sticky, thick sediment which will have settled. This sediment will have a consistency closer to that of tar than of oil. Near the bottom of the sludge oil trap, a large manhole cover is located and is positioned at the side of the sludge oil trap to enable removal of the sediment. A test valve with a funnel is also provided to check whether the dirty oil freely flows from the engine to the sludge oil trap and to make sure that the sludge oil trap does not become completely filled.

A design proposal for the WinGD sludge oil trap is provided in [Figure 4-61](#), [4-108](#). The specific design dimensions for the sludge oil trap are provided in the sludge oil trap drawings contained in the MIDS relevant for the leakage collection and washing system, [4-106](#).

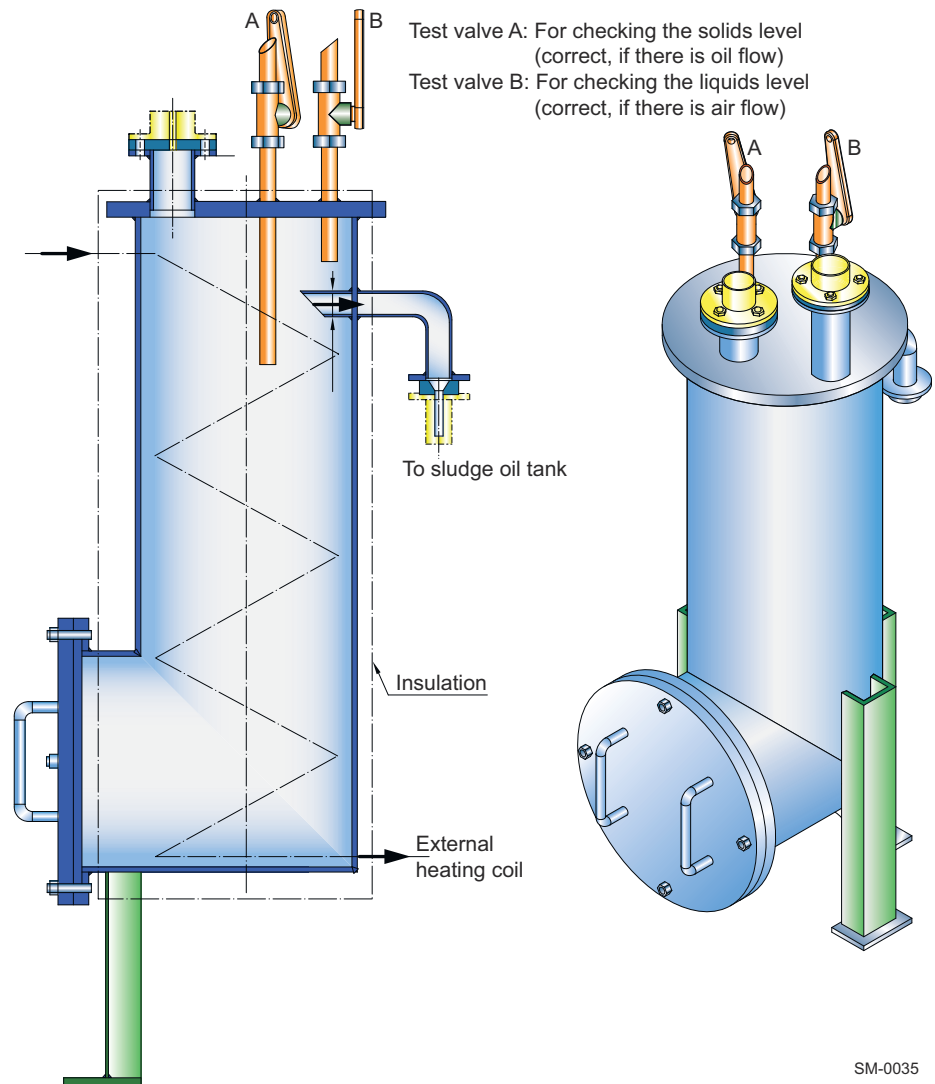

Figure 4-61 Design proposal of WinGD's sludge oil trap

Operation of the sludge oil trap

For monitoring the operation of the sludge oil trap, WinGD recommends checking the solids level in the sludge oil trap. The solids level can be assessed by opening the 'Test valve A' (see Figure 4-61). There must be an oil flow as otherwise the dirt will have accumulated above the maximum level. If there is no oil flow, then immediate sludge removal is required. The liquids level can be checked by opening the 'Test valve B' (see Figure 4-61). There must be an air flow, as this indicates that the oil drain is working properly. If instead there is an oil flow, this would indicate that the orifice of the overflow pipe is blocked and requires manual cleaning.

For manual sludge removal, partially unscrew and lift the cover to first drain the liquid to a tray, and then fully open the cover and manually remove the sludge.

Solution 2 description

Solution 2: A manually bottom-drained sludge oil trap

For the manual bottom-drain solution, there is no continuous drain to the sludge oil tank. The advantage of this solution is that it keeps the scavenge air loss to a minimum, while at the same time it ensures that the sludge oil tank is not at all pressurised during normal operation.

The piston underside drain is collected in the sludge oil trap. The flow is ensured by venting some air at the top of the sludge oil trap and through an orifice (5 to 10 mm inner diameter) to the atmosphere. In addition, a sight glass is installed in the venting pipe to check the air flow. An external heating device at the bottom of the sludge oil trap must be installed to ensure that the sludge emulsion can be properly drained through the manual bottom drain, which is activated by opening a manual valve.

There is a high-level alarm to inform the crew to drain the sludge oil trap.

Direct drain to the sludge oil tank

If the manual bottom drain is connected to the sludge oil tank, which is integrated in the double bottom structure, then the draining of the sludge will be pushed by scavenge air pressure and gravity. However, the manual bottom-drain valve must be closed quickly and as soon as the sludge oil trap becomes empty. Otherwise, the sludge oil tank will become pressurised by the scavenge air.

Transfer to the sludge oil tank by pump

If the manual bottom drain is connected to the intake of the sludge oil pump, then the sludge emulsion will be transferred to the sludge oil tank by this pump. The advantage of this solution is that the sludge oil tank can be installed at a different height than the double bottom level, while at the same time ensuring that the sludge oil tank will not be pressurised by opening the manual bottom drain.

Manual sludge removal

For manual sludge removal, partially unscrew and lift the cover to first drain the liquid to a tray, and then fully open the cover and manually remove the sludge.

A design proposal for the manually bottom-drained sludge oil trap is provided in [Figure 4-62](#).

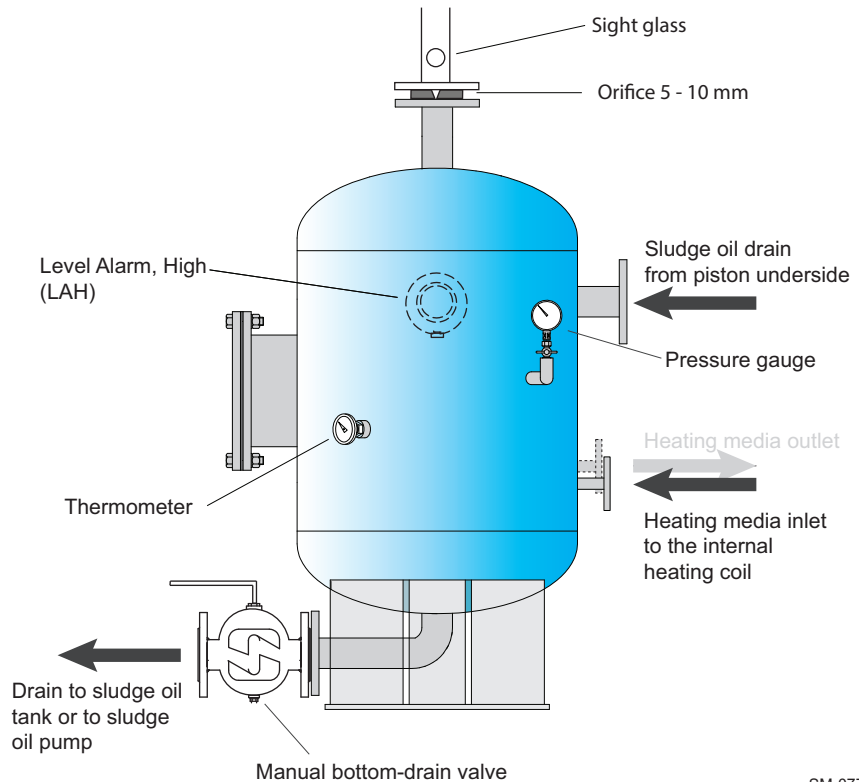

SM-0771

Figure 4-62 Design proposal of a manually bottom-drained sludge oil trap

*Solution 3: An automatically bottom-drained sludge oil trap***Solution 3 description**

For the automatic bottom-drain solution, there is no continuous drain to the sludge oil tank. The advantage of this solution is that it provides fully automatic operation of the bottom drain without manual crew operation. Also, this solution keeps the scavenge air loss to a minimum, while at the same time it ensures that the sludge oil tank is not at all pressurised during normal operation, as well as during drainage.

The basic design principle is the same as that of the manually drained sludge oil trap (i.e. Solution 2). The piston underside drain is collected in the sludge oil trap. The flow is ensured by venting some air at the top of the sludge oil trap and through an orifice (5 to 10 mm inner diameter) to the atmosphere. In addition, a sight glass is installed in the venting pipe to check the air flow. An external heating device at the bottom of the sludge oil trap must be installed to ensure that the sludge emulsion can be properly drained through the automatic bottom drain, which is designed as an automatic valve.

Automatic drainage

There is a high-level switch and a low-level switch to control the automatic bottom-drain valve. This valve automatically opens and closes the bottom drain. If the automatic bottom drain is connected to the sludge oil tank, which is integrated in the double bottom structure, then the draining of the sludge will be pushed by scavenge air pressure and gravity. The low-level switch will ensure quick closure of the automatic bottom-drain valve as soon as the sludge oil trap becomes empty. Otherwise, the sludge oil tank would become pressurised by the scavenge air. The advantage of the automatic drain solution, compared to the manual solution, is that the risk of blowing scavenge air to the sludge oil tank is eliminated.

Manual sludge removal

For manual sludge removal, partially unscrew and lift the cover to first drain the liquid to a tray, and then fully open the cover and manually remove the sludge.

A design proposal for the automatically bottom-drained sludge oil trap is provided in [Figure 4-63](#), [4-111](#).

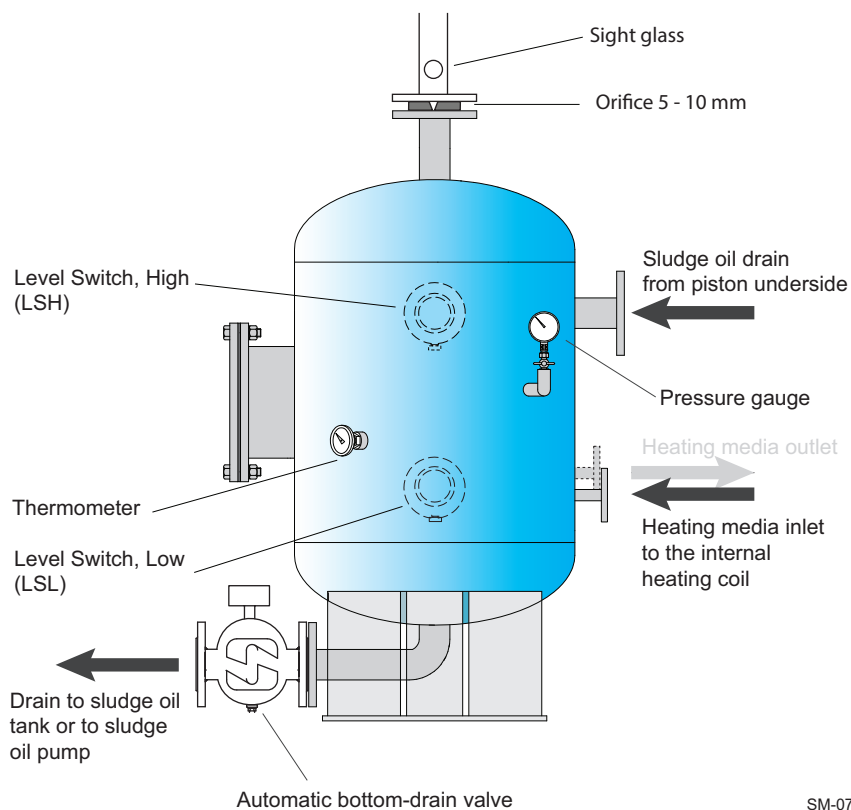

SM-0772

Figure 4-63 Design proposal of an automatically bottom-drained sludge oil trap

4.9.2 Draining of exhaust uptakes

Engine exhaust uptakes can be drained automatically using a system as shown in Figure 4-64.

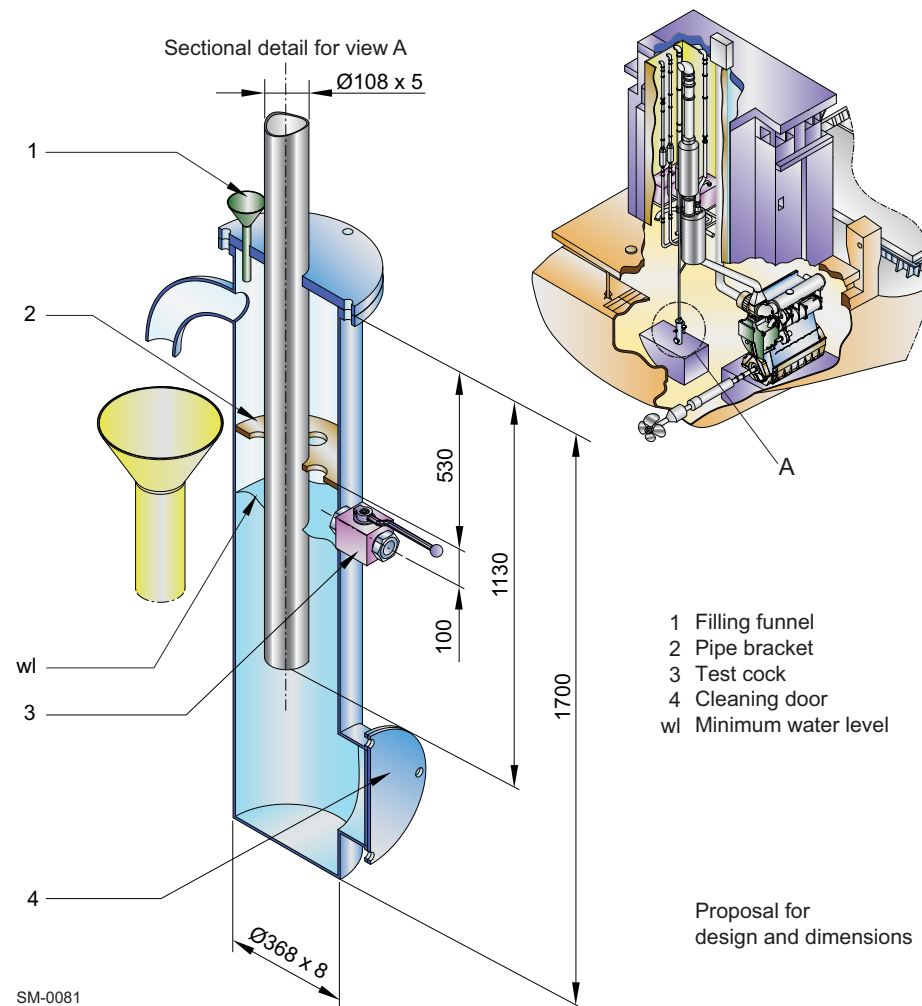

Figure 4-64 Arrangement of automatic water drain

4.9.3 Air vents

The air vent pipes of the ancillary systems have to be fully functional at all inclination angles of the ship at which the engine must be operational. This is normally achieved if the vent pipes have an uninterrupted inclination of min. 5%. Such arrangement enables the vapour to separate into its air and fluid components, discharging the air to atmosphere and returning the fluid to its source.

4.9.4 The iCER drainage system

The iCER drainage system is part of the iCER system. For details, refer to section 4.2.3, 4-8.

4.9.5 The SAC washing system

During engine operation, SAC tubes may become fouled with oil, grease, salts, dust, and other airborne contaminants. Especially during iCER operation, recirculating exhaust gas is a significant source of contamination. To address this, X-DF2.0 engines are equipped with an SAC wetting system, see section 4.2.4 The SAC wetting system, 4-20. Although this system prevents severe accumulation, an optional SAC washing system may be installed to perform more thorough cleaning at the discretion of the operator.

Offline SAC washing system (external system)

Functional description

The external SAC washing system washes the SAC while the engine is at standstill.

As shown in Figure 4-65, wash water is prepared in the chemical wash water circulation tank by mixing the chemical washing agent with freshwater in this tank. The filling amount depends on the type of SAC(s) installed. For the capacity selection, see the latest version of the MIDS.

Wash water is heated to between 50 and 60°C by a heating coil in the chemical wash water circulation tank. A circulation pump delivers the wash water to the spray nozzles located above the SAC. Washing over several hours may proceed, depending on the level of dirt accumulated. The used wash water returns through a strainer to the chemical wash water circulation tank.

When cleaning is finished, the wash water must be drained to a dedicated wash water storage tank for on-shore discharge.

The washing procedure must be followed by flushing with freshwater at 50 to 60°C to flush the SAC of washing agent residues. A flushing time of 30 to 60 minutes is recommended. Finally, the flushing water must also be drained to the dedicated wash water storage tank.

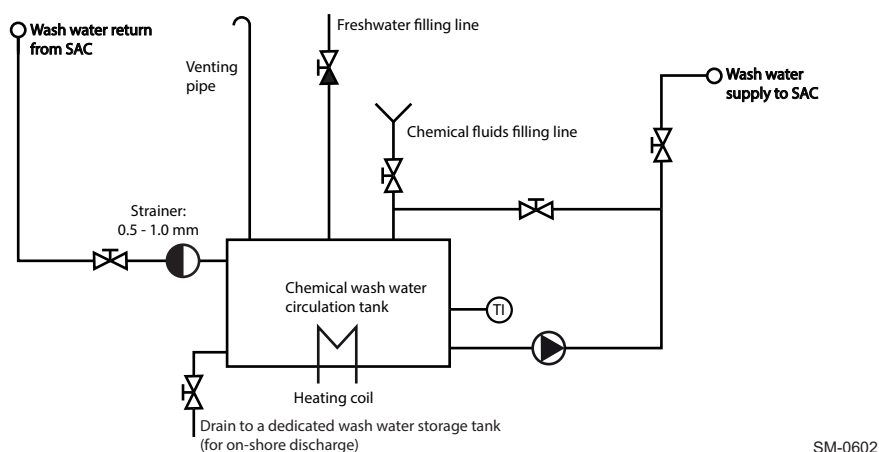

Figure 4-65 Offline SAC washing system (external system)

NOTE	<p>Offline washing must only be performed when the engine is at standstill and secured against starting.</p> <p>The recommended wash time and solution concentration is defined by the washing agent supplier.</p>
-------------	--

4.10 Exhaust gas system



The drawings relevant for the exhaust system (DG 9726) are provided on the WinGD webpage under the following link:

[MIDS](#)

Explosion relief devices

An explosion relief device examined and certified by the maker, with flameless pressure relief, must be selected and installed within the exhaust system in accordance with class requirements. The position and number of explosion relief devices must be determined by the system designer or the shipyard through calculation.

Independent of the selected type of explosion relief device, the distance of the explosion relief device to gangways, working areas and system components must be at least 3 m to not endanger personnel and/or to avoid material damage.

When a rupture disc with flameless pressure relief is selected and installed, preventative measures must be taken to ensure that exhaust gas does not continuously flow to the outside after rupture. This can be achieved with an exhaust gas duct leading to the open deck, or in the case of a twin-engine installation by sending a control signal to the Alarm and Monitoring System (AMS) requesting a shutdown of the engine. If either of these options are not possible, a self-closing, spring loaded valve must be used. This will remove the peak pressure of an explosion, while ensuring that the exhaust gas does not continuously flow outside.

Back pressure

The exhaust gas back pressure must be kept in the range as defined in the [MIDS](#) (DG 9726) and as mentioned in section 3.12.3, 3-22. To meet the specified back pressure requirements, the exhaust gas flow velocity must be considered.

Flow velocities

For an optimised exhaust gas system the following velocities are recommended for pipes A, B and C shown in [Figure 4-66](#), 4-114:

Pipe A = 40 m/s

Pipe B = 25 m/s

Pipe C = 35 m/s



For the pipe diameters please refer to the [GTD](#) application.

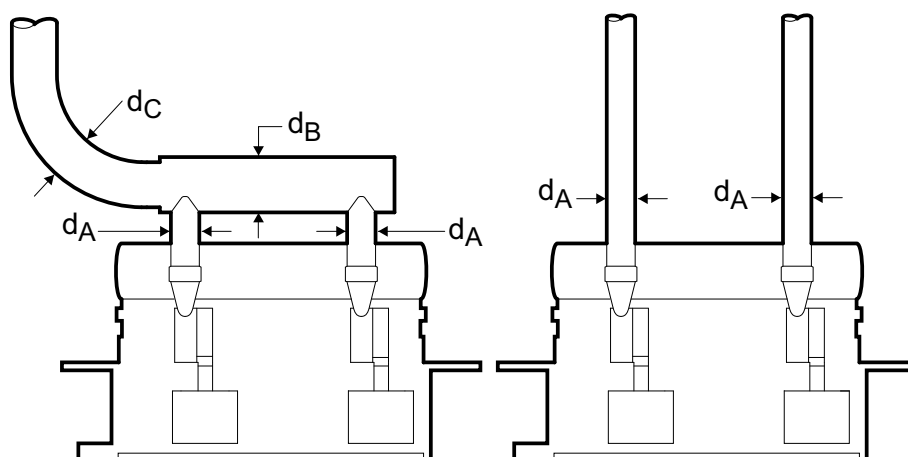

SM-0859

Figure 4-66 Determination of exhaust pipe diameter

4.10.1 The iCER exhaust gas system

The iCER exhaust gas system is part of the iCER system. For details, refer to section [4.2.5](#), [4-22](#).

4.10.2 Heat recovery (economiser)

A main economiser can be integrated into the exhaust gas system in different ways. An additional economiser can also be installed to recover thermal energy from the hot exhaust gases. The heat recovery system is part of the iCER system. For details, refer to section [4.2.6](#), [4-25](#).

4.11 Engine room ventilation

Special attention for the engine room ventilation is essential to ensure trouble-free operation of all equipment. It is important that the ventilation requirements, ventilation arrangement, air quality and outside ambient air temperature are taken into consideration.

4.11.1 Ventilation requirements

Engine room ventilation is to conform to the requirements specified by the legislative council of the vessel's country of registration and the classification society selected by the ship owner.

Calculation methods for combustion air flow requirements and for avoiding excessive heating of the machinery spaces are provided in the international standard ISO 8861 'Shipbuilding — Engine-room ventilation in diesel-engined ships — Design requirements and basis of calculations'.

The engine's combustion air is considered, and typically provided, as part of the overall engine room ventilation system. Approximately 50% of the overall engine room ventilation air is for the main engine's combustion, while the other half is used for the auxiliary engines, the boilers, and to provide sufficient cooling for equipment in the engine room. It is therefore vitally important that the ventilation system for the engine room has sufficient capacity to supply the necessary air flow for all engine room needs.



The heat emissions, required air flow and estimated power for the layout of engine room ventilation can be obtained from the *GTD* application. These values consider the ISO 8861 standard, however, in some circumstances the results are different from the standard calculations. In these cases, WinGD has provided the specific engine values and these should be considered before ISO 8861.

It should be noted that the engine requires less combustion air when not running at full load. This then provides potential energy savings by reducing the frequency of the ventilation fans when demand is low. This process can be automated, interfacing with the engine, if requested.

4.11.2 Ventilation arrangement

It is important to follow the best practice methods for supplying the combustion air for main engine as described in this section. However, the final layout of the engine room ventilation is at the discretion of the shipyard.

Two different ventilation arrangements

Experience shows that the air flow in the engine room, from the ventilation system outlet to the turbocharger inlets, should be as direct as possible. This increases the amount of air directly supplied to the turbocharger, limiting heat transfer to the air flow and therefore providing the best possible engine performance, especially during tropical conditions.

Alternatively, a ventilation system with a direct air suction layout can be arranged, where the ventilation system connects the outside ambient air directly to the engine.

These two different arrangements are discussed as follows:

- **Arrangement 1** — Engine room ventilation system (Figure 4-67, 4-118)
The ventilation system draws air from the outside ambient air into the engine room, where it is sucked into the turbocharger inlet.
- **Arrangement 2** — Direct engine ventilation system (Figure 4-68, 4-119)
The ventilation system outlet is connected to the turbocharger inlet. Therefore, the outside ambient air is sucked directly into the turbocharger without passing through the engine room.

NOTE

In both arrangements, the ventilation inlets must be located and designed to ensure that water spray, rain water, dust and exhaust gases cannot enter the system nor the engine room.

*Arrangement 1 — Engine room ventilation system***Functional principle**

The ventilation system draws air from outside the vessel using ventilation fans at the inlet. Ventilation inlets are typically protected with a weather hood and louvres to minimise the amount of water and other particles entering the system. The air travels to the engine room where it leaves the ventilation outlets and enters the engine.

Layout

The engine room ventilation should be arranged in such a way that the main engine combustion air is **delivered directly to the turbocharger inlet**, locating the ventilation outlet and turbocharger inlet as close as possible, and directly facing to each other, ensuring a smooth and direct flow of air.

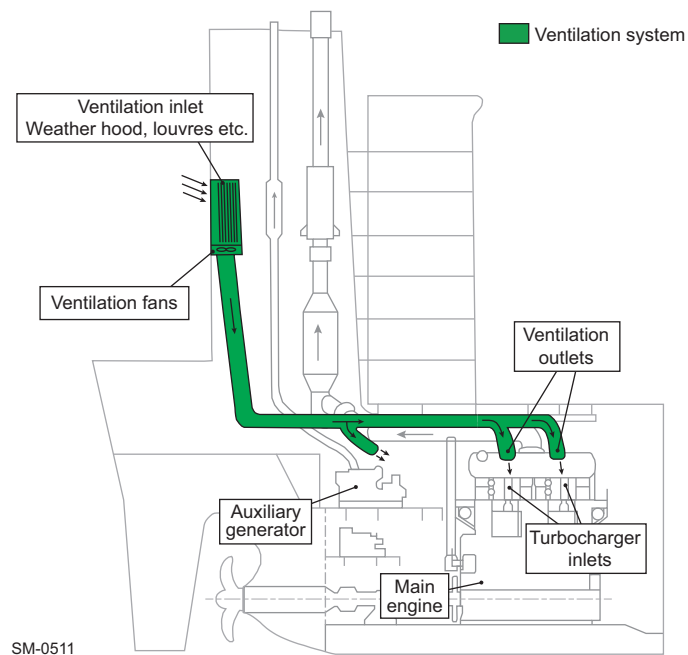

Figure 4-67 Ventilation system arrangement 1 — Engine room ventilation system

By ensuring that the air flow from the ventilation outlet to the turbocharger inlet is as direct as possible, the air intake is at its coolest. The ventilation arrangement should limit air from the engine room, mixing with the inlet air and entering the turbocharger. Limiting this heating effect will keep the engine's specific fuel consumption low as a consequence.

TC with filter

The turbocharger is fitted with a filter silencer that reduces noise and prevents large items from entering the turbocharger. Most turbocharger manufacturers supply an optional secondary fibre or mat filter that can further remove particles and oil mist. This can reduce the effort required for scavenge air cooler cleaning.

NOTE

WinGD recommends selecting the optional secondary filter to further assist with removing fine particles and oil mist that may be present in the engine room.

Arrangement 2 — Direct engine ventilation system

Layout In this arrangement, the ventilation outlets are coupled with the turbocharger inlets. As the turbochargers directly receive all the outside ambient air drawn via the ventilation system, there is little chance for the temperature to increase. As a result, this arrangement delivers cooler air to the engine than in 'Arrangement 1', reducing the engine's brake specific fuel consumption.

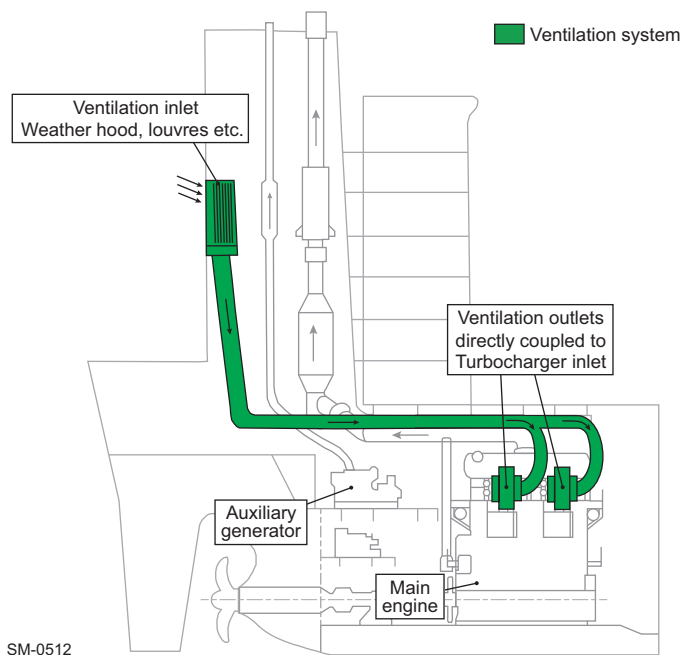

Figure 4-68 Ventilation system arrangement 2 — Direct engine ventilation system

The outside ambient air is drawn through the ventilation system by the turbochargers, and therefore there is no need for ventilation fans in this arrangement. However, it is still essential that the ventilation inlet is protected, typically with a weather hood and louvres. A separate filter unit, if required, can also be fitted here, within the inlet housing.

Requirements The engine room ventilation system is provided with separate ventilation fans and ducting. It should be appropriately sized to provide comfortable working conditions in the engine room, supply the necessary combustion air for auxiliary generator(s) and the boiler, and to prevent heat-sensitive apparatus from overheating.

As the main engine combustion air is no longer provided for by the engine room ventilation system, the energy demand of the ventilation fans is reduced compared to 'Arrangement 1'.

4.11.3 Air intake quality

Air intake quality can vary depending on the circumstances of the vessel. For example, suction air is expected to have a dust content of 0.5 mg/m^3 or higher if a vessel is carrying dusty or dust creating cargoes, such as iron ore and bauxite, or if it is often in port, trading in coastal waters and desert areas. In these cases, the air must be filtered before it enters the engine (see [Table 4-16](#)).

Dust filters The necessity for installing a dust filter and the choice of filter type depends mainly on the concentration and composition of dust in the suction air. The normal air filters fitted as standard to the turbochargers are intended mainly as silencers but not to protect the engine against dust. If the air supply to machinery spaces has a dust content exceeding 0.5 mg/m^3 , there is a risk of increased wear to the piston rings and cylinder liners.

NOTE

WinGD advises to install a filtration unit on vessels regularly transporting dust creating cargoes, or trading in areas of atmospheric dust.

Table 4-16 Guidance for air filtration

Dust concentration in ambient air			
Normal	Normal shipboard requirement	Alternatives necessary in very special circumstances	
Most frequent particle sizes	Short period < 5% of running time, < 0.5 mg/m^3	Frequently to permanently $\geq 0.5 \text{ mg/m}^3$	Permanently > 0.5 mg/m^3
> $5 \mu\text{m}$	Standard TC filter sufficient	Oil wetted or roller screen filter	Inertial separator and oil wetted filter
< $5 \mu\text{m}$	Standard TC filter sufficient	Oil wetted or panel filter	Inertial separator and oil wetted filter
---	Normal requirement for the vast majority of installations	These alternatives apply most likely to only very few extreme cases, e.g. ships carrying bauxite or similar dusty cargoes, or ships routinely trading along desert coasts.	

All filters' surfaces must be sized correctly to ensure full functionality of the filtration. This is dependent on the engine's maximum power output as shown in [Figure 4-69](#), [4-121](#).

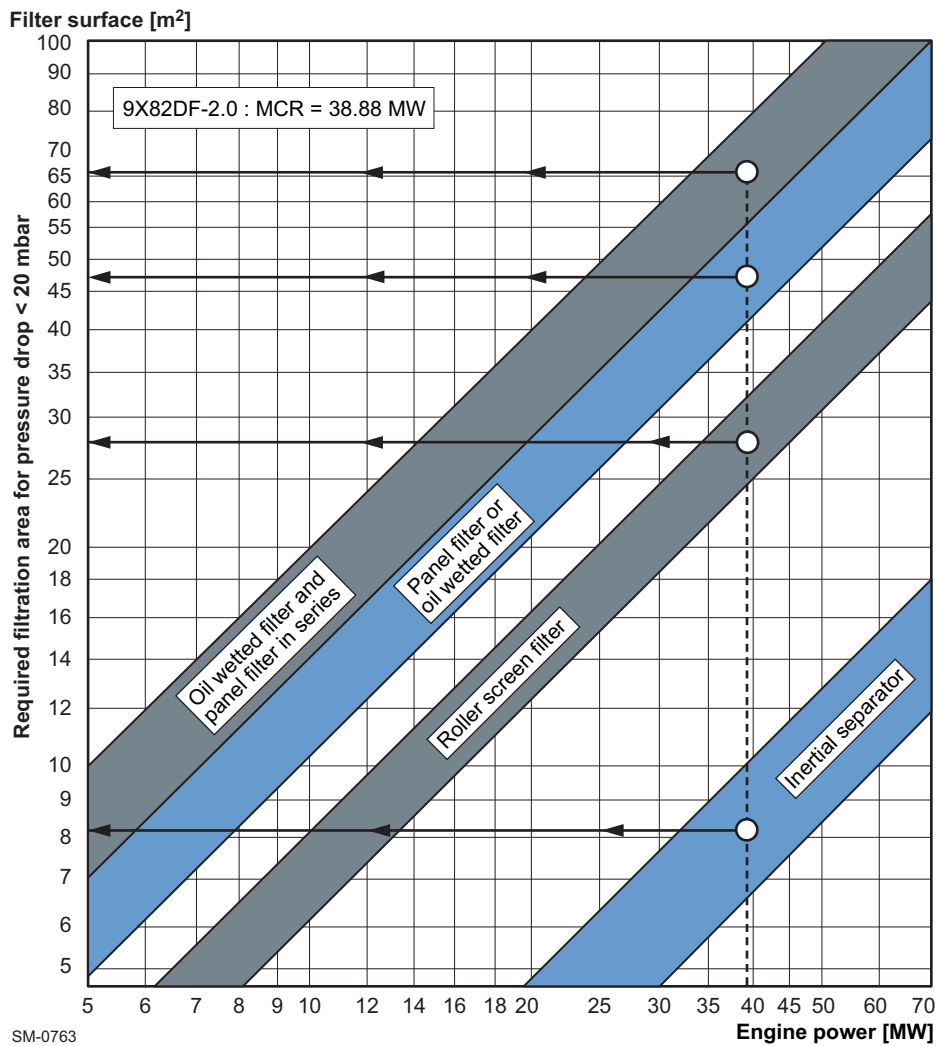

Figure 4-69 Air filter size (example for 9-cyl. engine)

4.11.4 Outside ambient air temperature

The intake air temperature can vary greatly depending on the area of operation, and as the engine may operate over a wide range of ambient air temperatures, hot and cold limits should be considered.

When operating within the normal temperature range of 5 to 45°C (see [3.12.2 Operating conditions](#), [3-21](#)), the engine does not require any special measures (i.e. no separate scavenge air heater is required). To operate below 5°C or above 45°C, please contact WinGD.

NOTE

No special measures are required for engine operation within the normal temperature range of 5 to 45°C.

4.12 Piping

4.12.1 Pipe connections



The latest versions of the **Pipe Connection Plan** (DG 8020) are provided on the WinGD webpage under the following links:

[Drawings](#) → [Pipe Connection Plan](#)

4.12.2 Fluid velocities and flow rates

For the different media in piping, WinGD provides recommended fluid velocities and flow rates as stated in the document 'Fluid Velocities and Flow Rates' (DG9730). The pump delivery head proposals provided by the *GTD* are based on system layouts which follow these recommended values. However, the values which are provided by this document are only for guidance purposes and the final pump layout must account for the final system layout. The values are based on the optimisation between installation and operating costs (pump energy). National and shipyard standards may also be applied.



The latest version of the document **Fluid Velocities and Flow Rates** (DG 9730) is provided on the WinGD webpage under the following link:

[Fluid Velocities and Flow Rates](#)

4.13 PTO, PTI, PTH and primary generator applications

WinGD proposes various Power Take-Off (PTO) and Power Take-In (PTI) arrangements that improve the efficiency and usability of the vessel's propulsion chain. Some of the proposals are even suitable as Power Take-Home (PTH) devices, which enable the vessel to immobilise the main engine while remaining capable of moving. Furthermore, the primary generator enables the vessel to generate electric power by the main engine without running the propeller.

A PTO/PTI/PTH solution can be applied on the driving end side, while a PTO solution can also be applied on the free end side.

For installation of a PTO/PTI/PTH on the driving end side, a shaft power meter (see subsection [Shaft power meter requirements](#), [1-10](#)) and an earthing device (see section [3.9.2 Earthing device](#), [3-16](#)) must be placed between the PTO/PTI/PTH and the main engine's flywheel.

NOTE

All other alternatives are subject to a detailed project-specific study and definition. Please consult WinGD via their licensee.

4.13.1 Requirements

After selecting the engine:

- 1) Define the shaft power and the shaft speed.
- 2) Estimate the electric power demand for propulsion purpose.
- 3) Evaluate which of the PTO / PTI systems is the most suitable.
- 4) Select suitable electrical components like frequency converter, etc.

NOTE

The type of the PTO/PTI system has an influence on the execution of the main engine. Thus, changing from one system type to another is possible in the project stage but not after having ordered the engine.

4.13.2 Arrangements for PTO, PTI, PTH and primary generator

[Figure 4-70](#), [4-125](#) illustrates the different arrangements for PTO, PTI, PTH and primary generator.

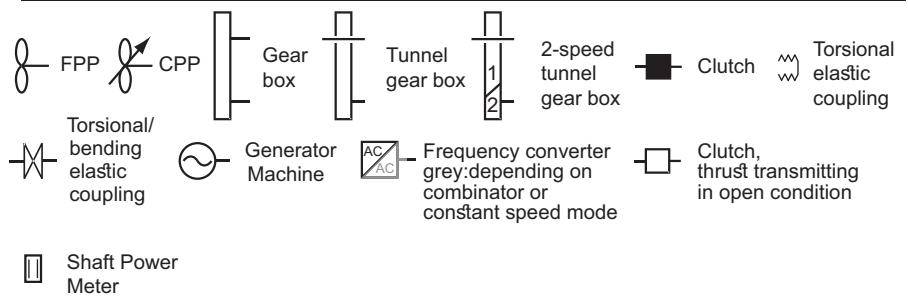
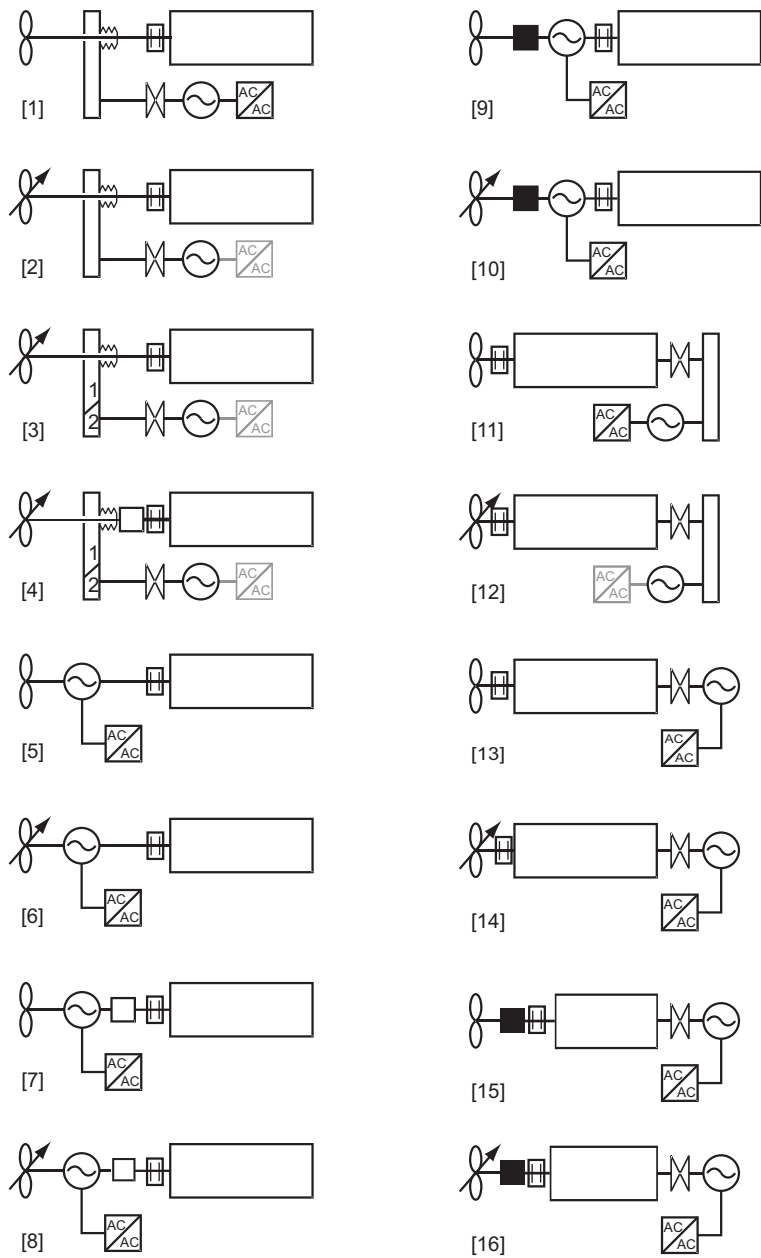

SM-0200

Figure 4-70 Arrangements for PTO, PTI, PTH

The following table itemises the arrangements corresponding to the numbers in Figure 4-70, 4-125.

Table 4-17 PTO/PTI/PTH arrangements for the WinGD X82DF-2.0

[1]	[2]	[3]	[4]	[5]	[6]	[7]	[8]	[9]	[10]	[11]	[12]	[13]	[14]	[15]	[16]
(X)	O	O	O	X	O	X	O	X	O	(X)	O	X	O	X	O
X = the arrangement is possible (X) = the arrangement may not be possible (too high nominal generator/el. motor torque due to too low nominal engine speed and/or high generator/el. motor power) O = the arrangement is not possible or plausible															

NOTE	In any case please check the application of arrangements for the selected engine with WinGD via their licensee. Project dependent options can also be considered.
-------------	---

4.13.3 Application constraints

The feasibility of project-specific PTO/PTI/PTH and primary generator needs to be studied in any case. An overview about impacts is given in Table 4-19, 4-127.

Table 4-18 Possible options for the WinGD X82DF-2.0

Option	Arrangements (see Figure 4-70, 4-125)															
	[1]	[2]	[3]	[4]	[5]	[6]	[7]	[8]	[9]	[10]	[11]	[12]	[13]	[14]	[15]	[16]
PTO	X	--	--	--	X	--	X	--	X	--	X	--	X	--	X	--
PTI	X	--	--	--	X	--	X	--	X	--	O	--	O	--	O	--
PTH	O	--	--	--	O	--	X	--	O	--	O	--	O	--	O	--
Primary generator	O	--	--	--	O	--	O	--	(X)	--	O	--	O	--	(X)	--
Remarks	a)								b)		a)				b)	
X = the option is possible (X) = the option is possible, however uncommon O = the option is not possible -- = the arrangement is not possible for the WinGD X82DF-2.0																

a) If the lowest torsional natural frequency is < 1.5 Hz, special care has to be taken regarding possible engine speed fluctuations.

b) With de-clutched propeller and pure generator operation, the minimum engine load requirement has to be obeyed.

Permanent Magnet

In cases where ‘Permanent Magnet’ type generators or electric motors are installed, special attention must be given to the alignment issue. Due to the low rotor mass in relation to the magnetic forces, a potential risk of unloaded shaft bearings may exist. In addition, bearing load measurements may be falsified by the influence of the permanent-magnetic pull force.

Table 4-19 Influence of options on engineering

Engineering	Arrangements (see Figure 4-70, 4-125)															
	[1]	[2]	[3]	[4]	[5]	[6]	[7]	[8]	[9]	[10]	[11]	[12]	[13]	[14]	[15]	[16]
Extended TVC	X	--	--	--	X	--	X	--	X	--	X	--	X	--	X	--
Misfiring detection	(X)	--	--	--	O	--	O	--	O	--	(X)	--	(X)	--	(X)	--
Impact on ECS	(X)	--	--	--	(X)	--	(X)	--	(X)	--	(X)	--	(X)	--	(X)	--
Shaft alignment study	(X)	--	--	--	X	--	X	--	X	--	(X)	--	(X)	--	X	--
Bearing load due to external load	(X)	--	--	--	X	--	X	--	X	--	(X)	--	X	--	X	--
Dynamic condition due to external load	O	--	--	--	O	--	O	--	O	--	X	--	X	--	X	--
X = the arrangement has an influence on this engineering aspect (X) = the arrangement might have an influence on this engineering aspect O = the arrangement has no influence on this engineering aspect -- = the arrangement is not possible for the WinGD X82DF-2.0																

Extended TVC The added components have a considerable influence on the related project-specific torsional vibration calculation. Proper case dependent countermeasures need to be taken depending on the results of the detailed TVC. For further details, refer to section 6.4.2 PTO/PTI systems effect on torsional vibration, 6-15.

Misfiring detection Depending on the results of the TVC, a misfiring detection device (MFD) might be needed to protect the elastic coupling and the gear-train (if present) from inadmissible torsional vibrations in case of misfiring.

Impact on ECS The PTO/PTI/PTH application has to be analysed via the licensee with the Propulsion Control System supplier and with WinGD for the Engine Control System.

Shaft alignment study The added components can have an influence on the alignment layout. The shaft bearing layout has to be properly selected and adjusted to comply with the given alignment rules. For further details, refer to section 3.6 Engine and shaft alignment, 3-13.

Bearing load due to external load The added components increase the bending moment and the related bearing loads. The bearing loads have to be checked for compliance with the given rules.

Dynamic conditions due to external load The components attached to the free end have to be checked for any influence on the axial and radial movements of the extension shaft caused by the dynamics of the engine.

4.13.4 Service conditions

The service condition depends on the selected PTO/PTI/PTH option. Depending on engine type there are one or several cases, which are illustrated below.

Operation area and prohibited area

The following illustrations indicate how the engine generator unit can be operated. The prohibited operation area is defined in section 2.7, 2-13.

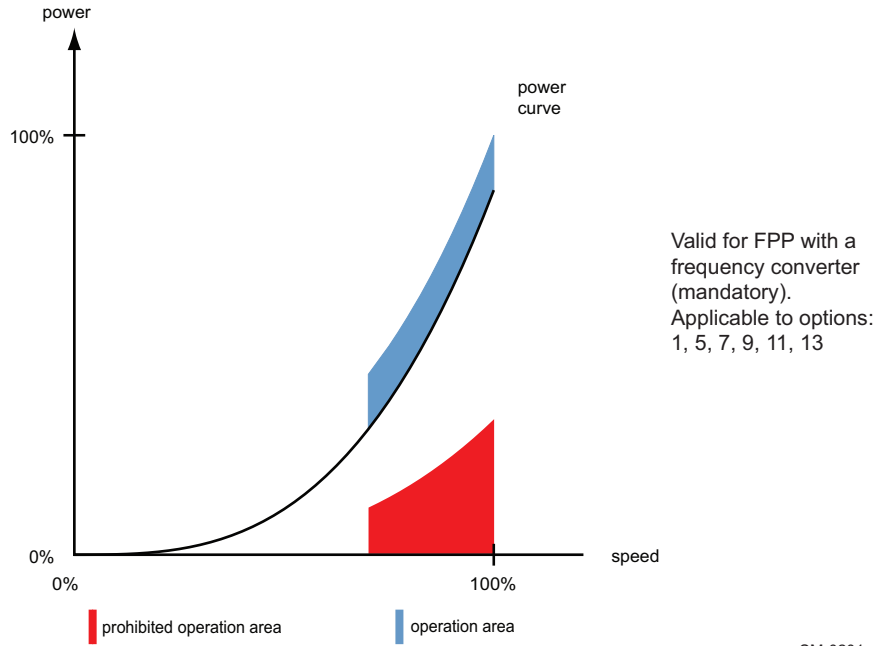

Figure 4-71 FPP with mandatory frequency converter

4.13.5 PTO application

When operating the X-DF engine with a PTO, the operation interaction between the engine and PTO must be evaluated. If one of the following conditions applies, project-specific evaluation is required:

- The ratio between PTO mechanical power and CMCR engine power is larger than 20%
- Operation of PTO is below 50% CMCR engine speed
- Working as a genset with a disconnected propeller
- The design requires special conditions such as ice operation, ice ramming, dynamic positioning, etc.

The above-mentioned engine operating conditions require simulation. Additionally, PTO connection and disconnection must be considered with special care. WinGD offers advisory services for assessing the feasibility of such configurations.

Experience has shown that engines with ratings close to R1 are more sensitive to power reduction (load down), ratings close to R4 are more sensitive to power increase (load up). The engine behaviour during these operating states can be improved by a lower rate of power change or by engine operation in diesel mode. As a guide, the maximum power increase and decrease rates are presented in Figure 4-72 and Figure 4-73, 4-130.

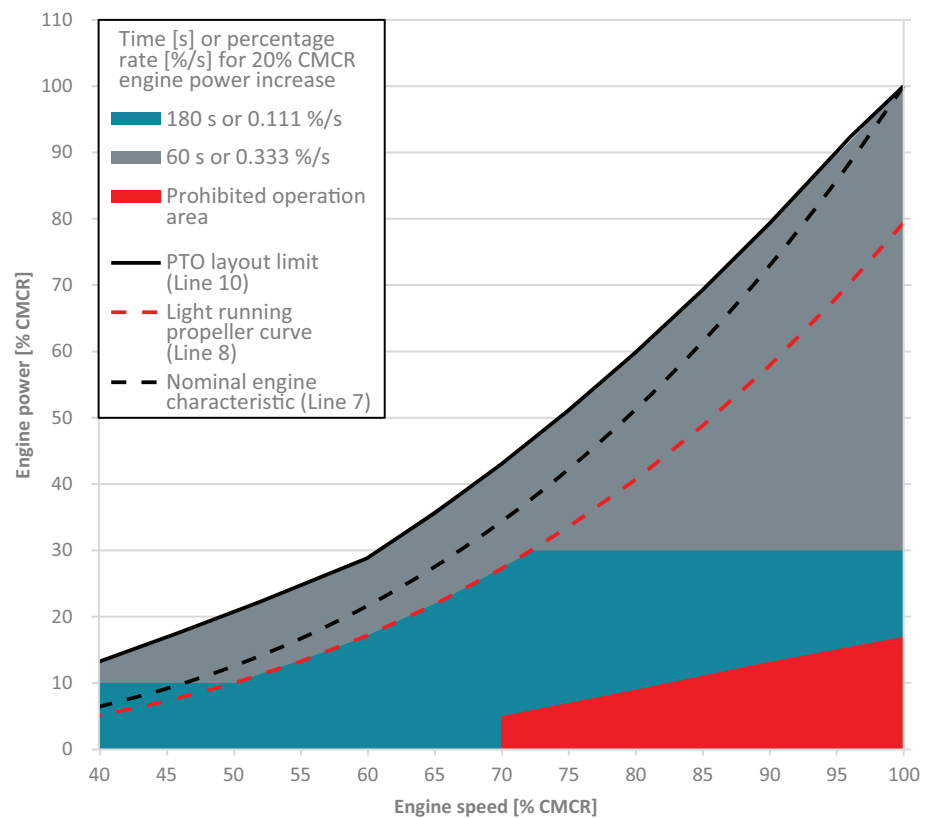
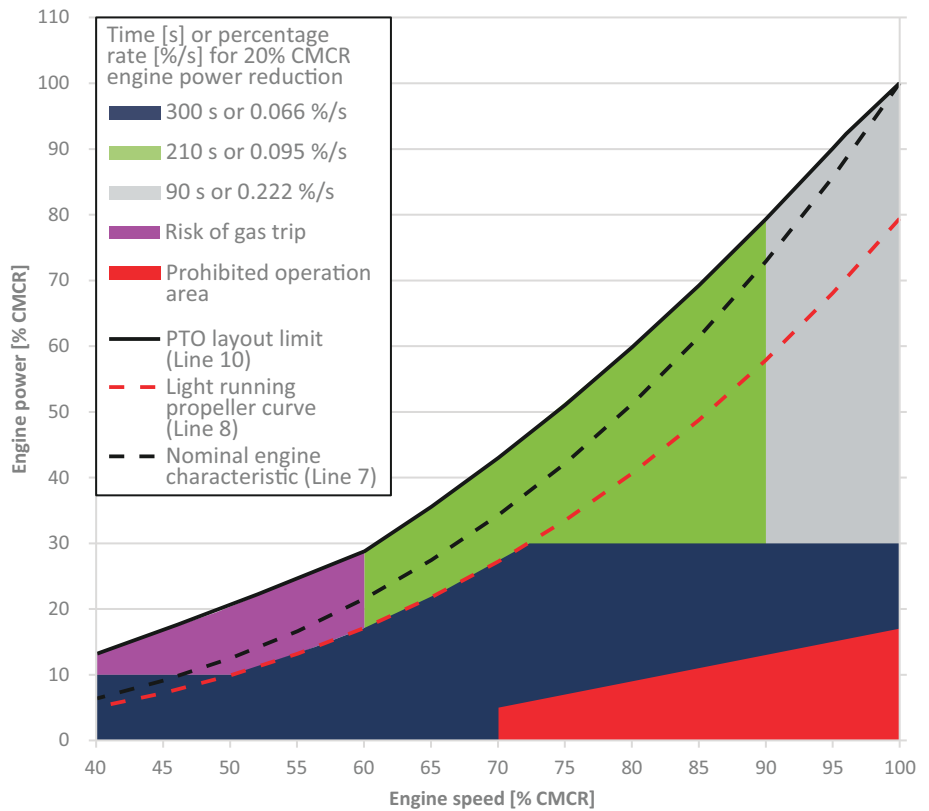

Figure 4-72 Maximum power increase rate for PTO application in gas mode



SM-0945

Figure 4-73 Maximum power decrease rate for PTO application in gas mode

Further services for evaluation of engine performance and X-EL advisory services

WinGD provides project-specific support services for safe engine operation (e.g. PTO/PTI applications, disengaged propeller operation, etc.), including X-EL systems and integration (e.g. PTO, battery-hybrid systems, and energy management control).

Please contact WinGD via the following e-mail address, along with any further questions:

electrification@wingd.com

Winterthur Gas & Diesel Ltd.
Sustainability Solutions
Schützenstrasse 3
8400 Winterthur
Switzerland

4.13.6 PTO testing



For testing purposes, the engine must have a complete torsional vibration calculation performed. If confirmed by the calculation, the engine can be operated at the CMCR speed and low load during a one-time period of 15 minutes on the testbed and 30 minutes during dock trials (e.g. shaft generator adjustment) in the presence of an authorised representative of the engine builder. If required, the test can be repeated. Further information is available on the WinGD webpage under the following link:

[Guideline for Shaft Generator Test with Disconnected Propeller during Dock Trial](#)

5 Engine Automation

The Engine Control System (ECS) provides data bus connection to the Propulsion Control System (PCS) and the Alarm and Monitoring System (AMS). The AMS is usually provided by the shipyard.

The leading suppliers of propulsion control systems approved by WinGD ensure complete adaptation to engine requirements.

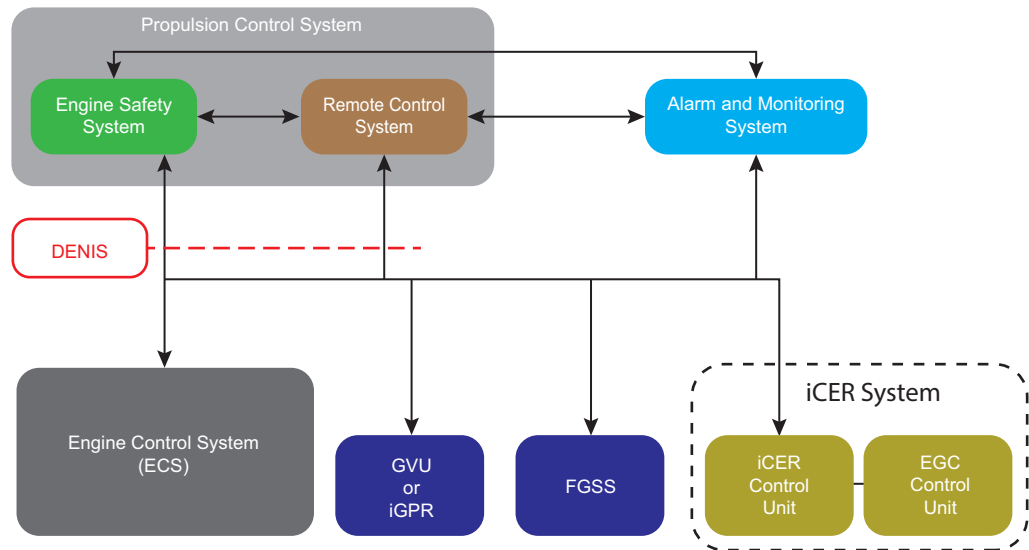

SM-0678

Figure 5-1 Engine automation architecture

5.1 DENIS

WinGD’s standard electrical interface is **DENIS**, which is in line with approved propulsion control systems.

DENIS The **Diesel Engine CoNtrol and optImising Specification** (DENIS) interface contains specifications for the engine management of all WinGD two-stroke marine diesel engines.

ECS WinGD provides a fully integrated ECS, which takes care of all Flex system-specific control functions, e.g. fuel injection, exhaust valve control, cylinder lubrication, crank angle measurement, and speed/load control. The system uses modern bus technologies for safe transmission of sensor signals and other signals.

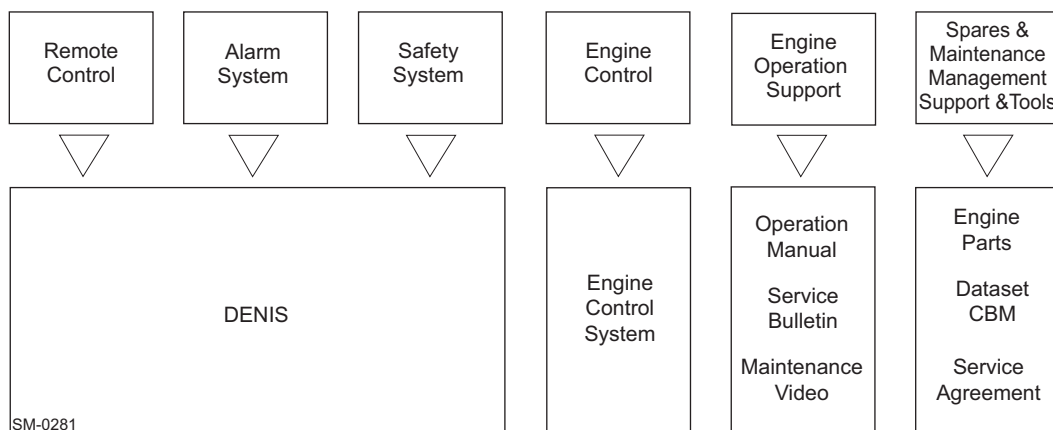

Figure 5-2 Engine management and automation concept

5.2 DENIS concept

The concept of DENIS offers the following features to ship owners, shipyards and engine builders:

5.2.1 Interface definition

The WinGD interface defines the division of responsibilities between engine builder and PCS and AMS supplier, enabling the authorised suppliers to adapt their systems to the common rail system engines. The data bus connection provides clear signal exchange.

5.2.2 Approved propulsion control systems

Propulsion control systems including remote control, safety and telegraph systems are available from suppliers approved by WinGD (see [Table 5-1](#), [5-4](#)). This cooperation ensures that the systems fully comply with the specifications of the engine designer.

5.3 DENIS specification

The DENIS specification describes the signal interface between the engine control system and the PCS and AMS. It does not include any hardware, but summarises all data exchanged and defines the control functions required by the engine.

The DENIS specification consists of two sets of documents:

5.3.1 DENIS interface specification

This signal interface specification is made available to engine builders and shipyards. Besides the description of engine-built components for control, alarm and indication, the specification contains the following:

- List of alarm and display functions to be realised in the vessel's AMS
- Control diagram of the engine
- Signal list including a minimum of functional requirements
- Information related to the electrical wiring on the engine

5.3.2 DENIS propulsion control specification

This document contains a detailed functional specification of the propulsion control system.

The intellectual property rights of this specification remain with WinGD. Hence the document is licensed only to the partner companies of WinGD developing propulsion control systems. These companies offer systems which are built exactly according to the engine designer's specifications and are finally tested and approved by WinGD.

5.4 Propulsion control systems

Approved propulsion control systems comprise the following independent sub-systems:

- Remote Control System (RCS)
- Safety system
- Telegraph system

The safety and the telegraph systems work independently and are fully operative even with the RCS out of order.

Approved remote control system suppliers

WinGD has an agreement with the marine automation suppliers listed in [Table 5-1](#) concerning development, production, sale and servicing of the RCS and the safety system. All approved control systems listed in this table comprise the same functionality specified by WinGD.

Table 5-1 Suppliers of remote control systems

Supplier		RCS
Kongsberg Maritime		
Kongsberg Maritime AS P.O. Box 1009 N-3194 Horten / Norway	km.sales@kongsberg.com Phone +47 81 57 37 00 www.km.kongsberg.com	AutoChief 600
NABTESCO Corporation		
NABTESCO corp., Marine Control Systems Company 1617-1, Fukuyoshi-dai 1-chome Nishi-ku Kobe, 651-22413 / Japan	newbuilding@nabtesco.com Phone +81 78 967 5361 www.nabtesco.com	M-800-V
Wärtsilä Lyngsø Marine A/S		
Wärtsilä SAM Electronics GmbH Behringstrasse 120 D-22763 Hamburg / Germany	www.sam-electronics.de	Wärtsilä NACOS PCS Platinum
Wärtsilä Lyngsø Marine A/S 2, Lyngsø Allé DK-2970 Hørsholm / Denmark	jan.overgaard@wartsila.com Phone +45 45 16 62 00 www.wartsila.com/lyngsoe	
CSSC-SERI		
CSSC Systems Engineering Research Institute 1 Fengxian East Road Haidian District, Beijing / P.R. China	aba11@163.com Phone +86 10 59516730 http://seri.cssc.net.cn/	CSSC-SERI-RCS- B01

Modern remote control systems consist of electronic modules and operator panels for display and order input in the Engine Control Room (ECR) and on the bridge (see [Figure 5-3](#), [Figure 5-5](#)). The different items normally communicate via serial bus connections. The engine signals described in the DENIS specification are usually connected via terminal boxes on the engine with the electronic modules placed in the ECR.

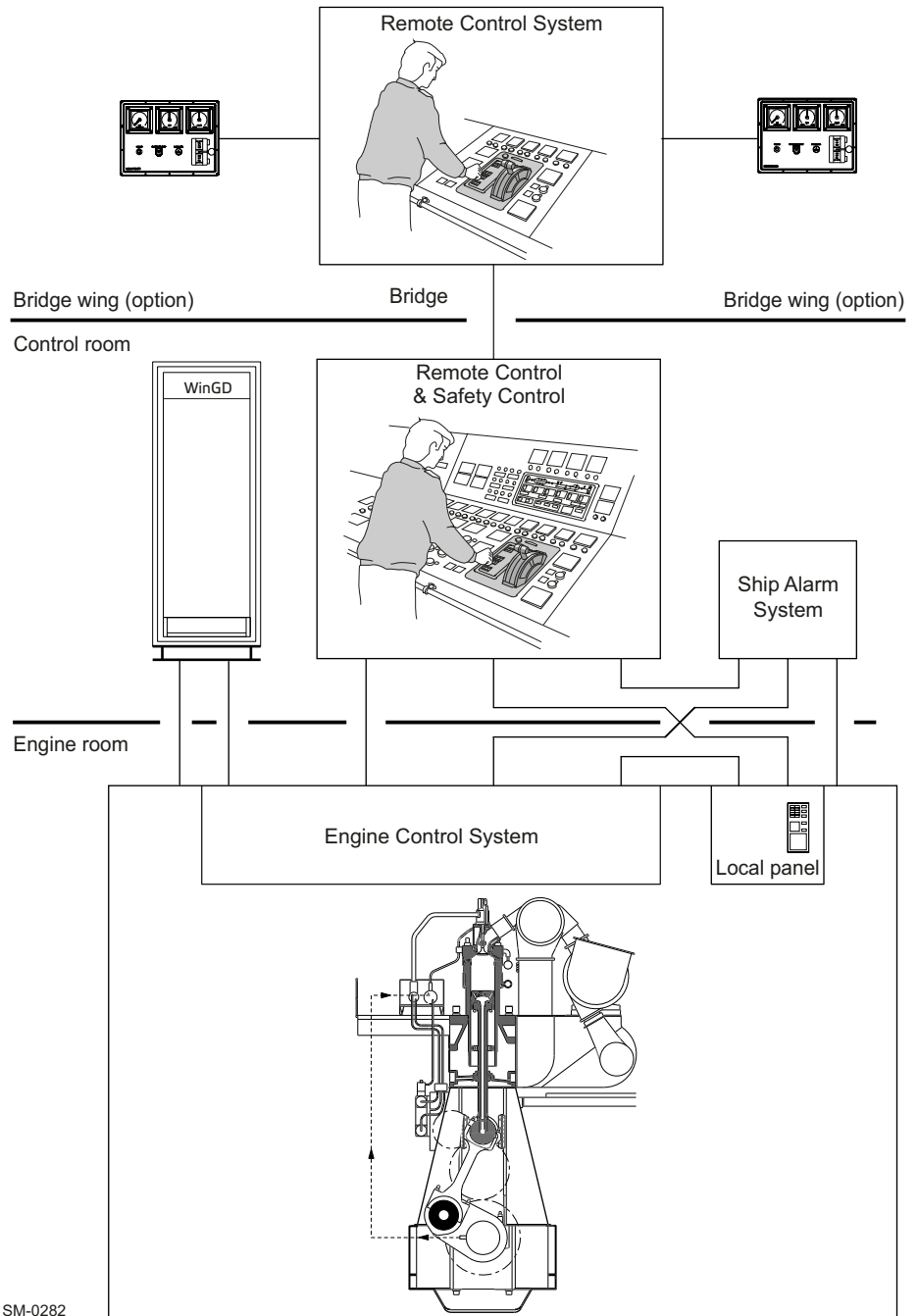

SM-0282

Figure 5-3 Remote control system

The electronic modules are in most cases built to be placed either inside the ECR console, or in a separate cabinet to be located in the ECR. The operator panels are to be inserted in the ECR console’s surface.

5.4.1 Functions of the propulsion control system

Remote control system

- Main functions**
- Start, stop, reversing
 - Speed setting
 - Automatic speed program
- Indications**
- The RCS is delivered with control panels for local, ECR and bridge control, including all necessary order input elements and indications, e.g. push buttons / switches and indication lamps or alternatively a respective display.
 - The following conditions in the engine are specified by the DENIS to be indicated as a minimum:
 - In the control room:
 - Starting air pressure
 - Engine speed
 - Revolutions
 - Operating hours
 - Load
 - Turbocharger speed
 - Scavenge air pressure in air receiver
 - On the bridge:
 - Starting air pressure
 - Engine speed
 - In addition to these indications, the RCS applied to the common rail system engine includes displaying the primary values from the ECS, like fuel pressure, servo oil pressure, etc.

Safety system

- Main functions**
- Emergency stop
 - Overspeed protection
 - Automatic shut-down
 - Automatic slow-down

Telegraph system

- Order communication between the different control locations

Local manual control

- Local manual control of the engine is performed from a control panel located on the engine. The panel includes elements for manual order input and indication for the safety system, telegraph system and ECS.
- The local control box with the local manual control panel is included in the package delivered by approved RCS suppliers.

ECR manual control panel

- A manual control panel delivered together with the PCS and fitted in the ECR console allows operating the engine manually and independently of the RCS.
- The functions of the ECR manual control are identical to the control functions on the engine's local control panel.

Options

- Bridge wing control
- Command recorder

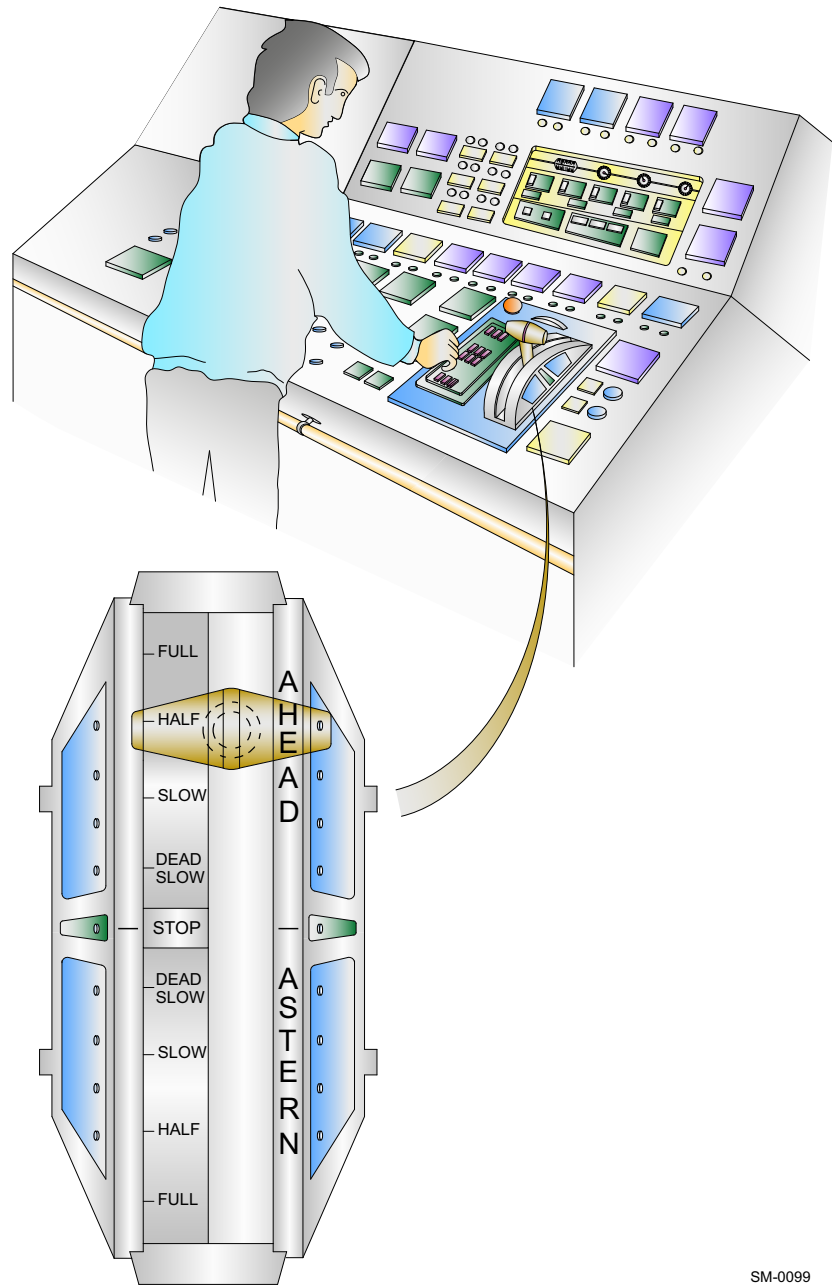

Figure 5-4 Propulsion control

SM-0099

5.4.2 Recommended manoeuvring characteristics

The vessel speed is adjusted by the engine telegraph. Manoeuvring, e.g. for leaving a port, is available from full astern to full ahead. For regular full sea operation, the engine power can be further increased up to 100% CMCR power.

To protect the engine, any increase or decrease in power is limited by a rate of change, considering the warm-up respectively cool-down times. Therefore, depending on the magnitude of any change in power, it takes time to reach the required engine output; see [Table 5-2](#), [5-9](#) and [Figure 5-6](#), [5-9](#).

Recommended values for
the manoeuvring positions
in percentage of CMCR speed

60 - 70	FULL	AHEAD
45 - 55	HALF	
35 - 45	SLOW	
25 - 35	DEAD SLOW	
	STOP	
25 - 35	DEAD SLOW	ASTERN
35 - 45	SLOW	
45 - 55	HALF	
60 - 70	FULL	

SM-0212

Figure 5-5 Manoeuvring speed/power settings for FPP/CPP installations

For further information about the range of operating modes, refer to section [1.3 Fuel operating modes](#), [1-7](#).

FPP manoeuvring steps and warm-up times

The recommended manoeuvring steps and warm-up times for engine speed increase are indicated in [Table 5-2](#). The engine speed-up/down program is included in the ECS.

Table 5-2 Recommended manoeuvring steps and warm-up times for FPP

Manoeuvring position	Recommended CMCR speed [%]	Corresponding power [%]	Recommended warm-up time per load step [min]	Min. warm-up time per load step [min]										
DEAD SLOW	25 - 35	1.5 - 4.5	0	0										
SLOW	35 - 45	4 - 9	0	0										
HALF	45 - 55	9 - 17	0.1	0.1										
FULL	60 - 70	22 - 34	0.5	0.5 </tr <tr> <td>FULL SEA 1</td> <td>92</td> <td>78</td> <td>45</td> <td>34</td> </tr> <tr> <td>FULL SEA 2</td> <td>100</td> <td>100</td> <td>60</td> <td>45</td> </tr>	FULL SEA 1	92	78	45	34	FULL SEA 2	100	100	60	45
FULL SEA 1	92	78	45	34										
FULL SEA 2	100	100	60	45										

Load reduction is possible in half the time of values mentioned in [Table 5-2](#).

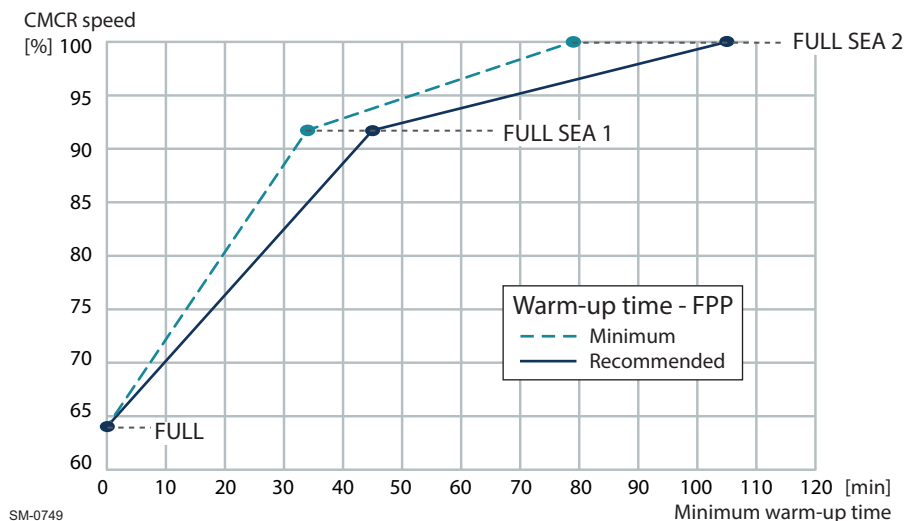

Figure 5-6 Full sea load steps in FPP load-up program

NOTE After reaching 100% CMCR speed (FULL SEA 2), the speed can be further increased according to the load-up program. This can be carried out until the engine reaches the maximum speed (see the speed limit lines in [Figure 2-3](#), [2-6](#)), while taking into account the light running margin (see [Light running margin](#), [2-5](#)).

5.5 Alarm and monitoring system

To monitor common rail system-specific circuits of the engine, sensors with hardwired connections are fitted. In addition to that, the engine control system provides alarm values and analogue indications via data bus connection to the ship's alarm and monitoring system.

5.5.1 Integrated solution

PCS and AMS
from same supplier

- The PCS and AMS are connected to the ECS through one redundant bus line (CANopen or Modbus, depending on automation maker).
- The integrated solution allows an extended presentation of relevant parameters and easy access to alterable user parameters backed by the graphical user interface functions available in the AMS.
- With the AutoChief 600 Alarm and Monitoring System by Kongsberg Maritime even the conventional sensors and additional Flex system-specific sensors can be connected via data bus lines, and the data acquisition units can be mounted on the engine in the same boxes used as terminal boxes for any other AMS. These boxes are usually provided by the shipyard and have to be delivered to the engine builder for mounting on the engine and connecting to the sensors.
- The integrated solution facilitates commissioning and testing of the alarm signals set on the engine maker's testbed and limits the wiring at the shipyard to a few power cables and bus communication.

5.5.2 Split solution

PCS and AMS
from different suppliers

- The PCS is connected to the ECS through two redundant bus lines (CANopen or Modbus, depending on automation maker).
- For the separate AMS an additional redundant Modbus connection is available.
Requirements for any AMS to be fulfilled in a split solution:
 - Possibility to read values from a redundant Modbus line according to standard Modbus RTU protocol
 - Ability to display analogue Flex system values (typically 20 values) and add alarm values provided by the ECS to the standard alarm list (300-800 alarms depending on engine type and number of cylinders)

With this solution the HMI is split as well:

- The remote control system includes the following functions:
 - Changing of parameters accessible to the operator
 - Displaying the parameters relevant for engine operation
- The alarm and monitoring system includes the display of:
 - Flex system parameters such as fuel pressure, servo oil pressure, etc.
 - Flex system alarms provided by the ECS
- WinGD provides Modbus lists specifying the display values and alarm conditions as part of the DENIS specification.

5.6 Alarm sensors and safety functions

To ensure safe operation the engine is provided with alarm sensors and safety functions.

5.6.1 Signal processing

Signal processing has to be performed in the alarm and monitoring system. WinGD provides a separate document named 'Usual values and safeguard settings', which lists the signal indication values. This includes the alarm function and alarm level with corresponding setting and response time.



The document **Usual values and safeguard settings** for the WinGD X82DF-2.0 can be found under the following link:

[*Usual values and safeguard settings*](#)

Please note that the signalling time delays given in this document are maximum values. They may be reduced at any time according to operational requirements. When decreasing the values for slow-down times, the delay times for the respective shut-down functions are to be adjusted accordingly.

NOTE

The delay values are not to be increased without the written consent of WinGD.

5.6.2 Requirements of WinGD and classification societies

The scope of delivery of alarm and safety sensors has to cover the requirements of the respective classification society, WinGD, the shipyard and the owner. For the list of classification societies see section 9.1, [9-1](#).

The alarm sensors and safety functions listed in the document [*Usual values and safeguard settings*](#) are mandatory for an unattended machinery space and reflect the minimum requirements of WinGD. For additional requirements from the classification societies see [Table 5-3](#).

NOTE

In case the engine has been configured for attended machinery space, please consult the respective classification society.

Table 5-3 Additional class requirements for alarm sensors and safety functions

Table under preparation

5.7 WinGD Integrated Digital Expert (WiDE)

The WinGD Integrated Digital Expert (WiDE) provides full awareness of the ship’s operating condition and allows operators to take necessary actions to control and optimise ship operations. The shore connection allows the ship’s operator to manage and optimise fleet operations.

WiDE constantly collects all engine signals together with ship navigation data making them available both on board and onshore. Engine data is collected and analysed by the engine diagnostic algorithms of WiDE to monitor engine performance, predict component malfunctions and to support the crew with live troubleshooting and a diagnostic advisory service. WiDE also enhances remote troubleshooting support by WinGD experts.

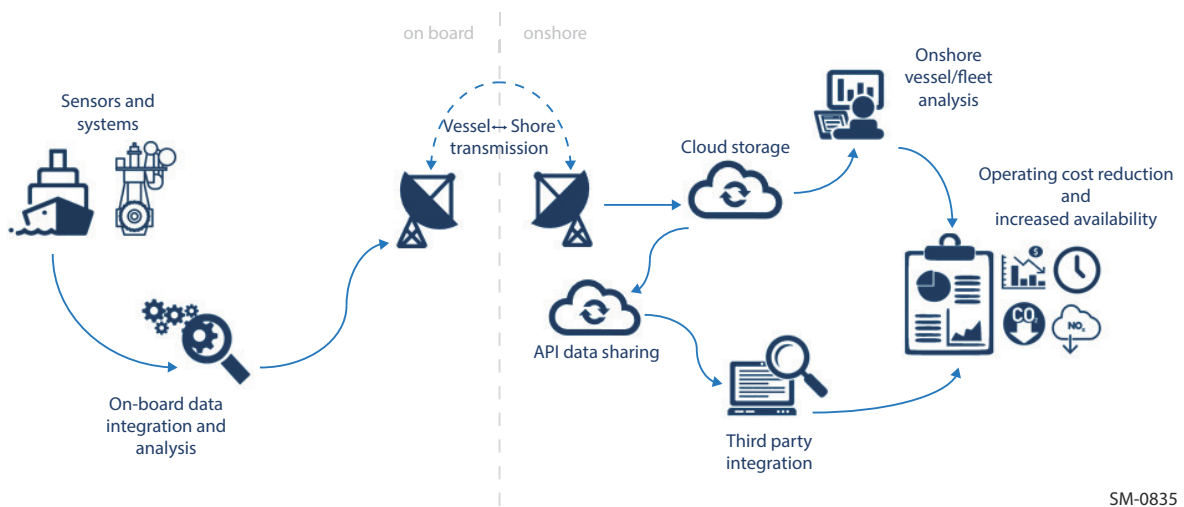

SM-0835

Figure 5-7 The WiDE data collection and analysis process

5.7.1 Data collection

WiDE collects engine and other ship data, which is stored on board by the WiDE computer, enabling the crew to display and review trends of key engine parameters.

Data collected by WiDE is sent via a secure encrypted communication channel to the WinGD server. The data is made available on two dedicated web portals (eVesselTracker, WiDE online) accessible by a protected user account. WinGD experts review engine data when required, as a first step of remote operation support. The WiDE computer is delivered as standard with WinGD engines.

5.7.2 Engine diagnostic module

The engine diagnostic module of WiDE analyses the engine data against predefined references in real time, identifying deviations between the measured and reference data. The results are then consolidated and potential issues are highlighted to the crew. Recommendations are provided for corrective actions, allowing operators to improve engine operation and optimise engine performance and maintenance planning. Spare parts information is provided to support maintenance.

Analysis WiDE analyses the engine data to obtain a full diagnostic assessment using several methods:

- The ‘digital twin’, an engine thermodynamic model which is calibrated at the engine’s shop test and sea trial, receives and is simulated by real-time engine parameter inputs. This provides an ongoing performance assessment by measuring deviations between the digital twin and the real engine.
- An algorithm rule set, which is based on WinGD’s expert knowledge, is used to monitor, analyse and diagnose the health of engine components
- Data monitoring and collection also enables a progressive performance evaluation and improvement

Prediction and troubleshooting

The real time engine analysis performed by WiDE provides an early anomaly detection warning. If a potential fault is diagnosed, the operator is notified, enabling them to decide on immediate action. The WiDE troubleshooting process is described in the following sequence:

- Initial proposed actions follow the directions of the engine operation manual
- If required, WiDE enables connection to WinGD experts for technical support and remote troubleshooting
- WiDE also creates relevant reports for future reference

Support In addition, WiDE maintains a record of events on the main engine and has a module to support planned maintenance. Spare parts required for maintenance tasks can be listed. This checks the available stock level and provides orders accordingly.

Software availability WinGD provides the WiDE engine diagnostic software on a ‘Software-as-a-Service’ basis. The software license is provided as part of an annual subscription plan that includes other services such as troubleshooting support, performance reports and recommendations from WinGD experts.

For more information regarding subscription plans and services offered by WinGD, please contact the WinGD representative or visit the WinGD webpage using the following link:

<https://www.wingd.com/en/digital-solutions/wide/>

5.7.3 The WiDE installation process

Figure 5-8 shows the installation steps of WiDE. The WiDE computer is installed before the shop test as the data it collects provides the information required for the engine’s digital twin. The process ensures that the WiDE system is fully operational by the time of the vessel’s maiden voyage.

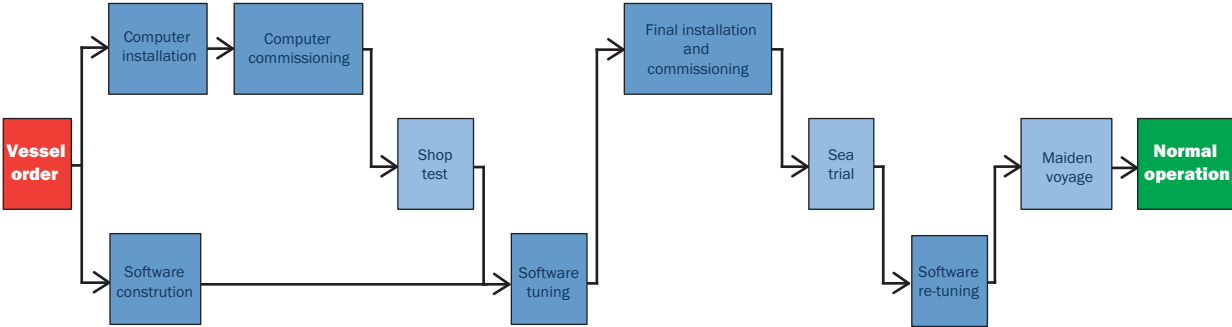

SM-0497

Figure 5-8 The WiDE installation process

5.8 The intelligent combustion control

Intelligent Combustion Control (ICC) is a set of automatic cylinder pressure control functions in the ECS, which enable safe and reliable engine operation according to original shop test performance. ICC functions stabilise and optimise the fuel combustion process for all engine operation modes to achieve the required engine power and fuel consumption within emissions limits.

5.8.1 ICC control functions

ICC consists of three functions to control cylinder pressure. In all cases, the range by which the system can offset the control parameter is limited to maintain emissions requirements and prevent engine damage.

Compression balancing

The ECS automatically calculates and adjusts the cylinder compression pressure via a unique exhaust valve closing angle offset for each cylinder. This achieves consistent compression pressure across all engine cylinders.

Firing balancing

In diesel mode, the ECS automatically adjusts cylinder firing pressures to be consistent across all cylinders by varying the injection begin angle by a unique offset for each cylinder.

In gas mode, the ECS automatically adjusts cylinder firing pressures to be consistent across all cylinders by varying the gas fuel admission quantity by a unique offset for each cylinder.

Firing control

In diesel mode, the ECS automatically offsets injection begin angles so that firing pressures match testbed values. The offset is the same for all engine cylinders.

In gas mode, the ECS automatically offsets the pilot fuel injection timing to achieve testbed firing pressures. The offset is the same for all engine cylinders and cannot be switched off.

5.8.2 ICC activation modes

In normal operation, it is recommended to keep all available control options ON. In some circumstances it can be helpful to turn individual modes OFF, such as:

- Problems with a cylinder unit (e.g. fuel injection, exhaust valve or ECS issues)
- Loss, damage or drift of two or more cylinder pressure sensors
- Extreme weather conditions which may lead to unstable control
- Running-in or recovery of the cylinder liner
- During troubleshooting

In case of a single damaged cylinder sensor, ICC controls are only deactivated on the unit where the sensor failed.

5.8.3 ICC data

Cylinder pressure sensors installed on each cylinder provide real-time measurement data for ICC, which is used to supply the following information.

Compression pressure Direct measurement of the compression pressure of each cylinder is not possible. For this reason, the individual compression pressure is calculated based on the measured cylinder pressure during the compression phase of each cylinder. Compression pressure is processed during each cycle and over the full engine power range. An average value of all units' compression pressures is also calculated.

Firing pressure Peak firing pressure is directly measured for each cylinder. An average value of all firing pressures is also calculated.

Firing pressure angle The crankshaft angle of the peak firing pressure is measured for each cylinder. An average value of all cylinders is also calculated.

ISO corrected firing pressure ISO corrected firing pressure is calculated at all engine loads based on the IMO technical file [Figure 5-9](#). These pressures are dependent on the engine tuning and require additional ISO correction sensors:

- Two scavenge air temperature sensors, located after the scavenge air cooler. These sensors provide actual scavenge air temperatures.
- Two barometric pressure sensors, located next to the turbocharger (or between the turbochargers in case of multiple turbochargers). These sensors provide the ambient air pressure.
- Two air temperature sensors, located next to the turbocharger (or between the turbochargers in case of multiple turbochargers). These sensors provide the ambient air temperature.

This ISO correction is only applied in diesel mode operation with firing control.

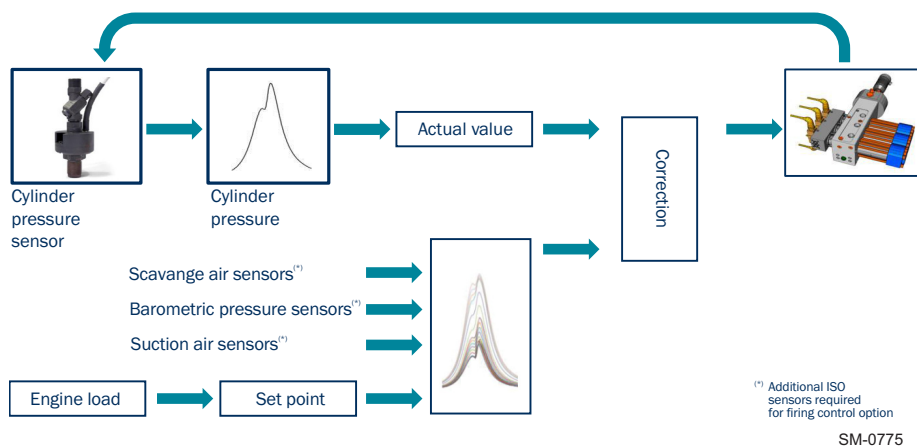

Figure 5-9 The ICC system

6 Engine Dynamics

It is critical that vibration is minimised throughout the design and construction stage of any engine installations. The assessment and reduction of vibration are subject to continuous development and research, requiring expert knowledge. For successful design, vibration behaviour calculations are required over the whole operating range of the engine and the propulsion system. As such, WinGD has developed extensive computer software, analytical procedures and measuring techniques.

NOTE

WinGD provides additional support services to assist with system dynamics and vibration analysis. For additional information about forms and links, please see section 6.9, [6-23](#).

Forces and moments causing vibrations

Within the engine, various forces and moments are generated by the reciprocating and rotating masses. Often these cyclical forces and moments are neutralised by counterbalancing within the engine. However, if this is not achieved the engine will experience the sum of these forces and moment as external responses, reacting around its own axis and causing vibrations outside of the engine. Vibrations are problematic, especially if a vibration frequency forces a resonance, causing an amplitude to pass acceptable limits. This section highlights the importance of dynamic consideration, the causes and relevance.

After considering the external forces and moments types, this section explores the resulting vibration, along with recommended considerations and countermeasures relevant to engine type and other associated systems and design features.

Types of vibration

The vibration types considered in this section are as follows:

- External mass forces and moments
- External lateral forces and moments (Lateral engine vibration or 'rocking')
- Longitudinal engine vibration
- Torsional vibration of the shafting
- Axial vibration of the shafting
- Whirling vibration of the shafting
- Hull vibration

Dynamic characteristics data

The external forces and moments generated by a specific engine defines its dynamic characteristics. These must be considered throughout the design process of the vessel to avoid adverse impact on the vessel.



In the document **External forces and moments** WinGD provides a complete list of the external forces and moments for each engine type. The latest version of this document is provided on the WinGD webpage under the following link:

[External forces and moments](#)

The external forces and moments for engines not tuned to an R1 rating are available on request.

6.1 External mass forces and moments

The external mass forces and moments are the resulting forces and moments produced by reciprocating and rotating masses of the running gear (i.e. the engine's main oscillating masses) that are transmitted to the surrounding vessel via the foundation. Therefore, this does not consider forces and moments that are produced by combustion forces (see section 6.2, 6-5). The external mass forces and moments depend on the design of a specific engine and the engine speed. The engine power has no influence on the external mass forces and moments.

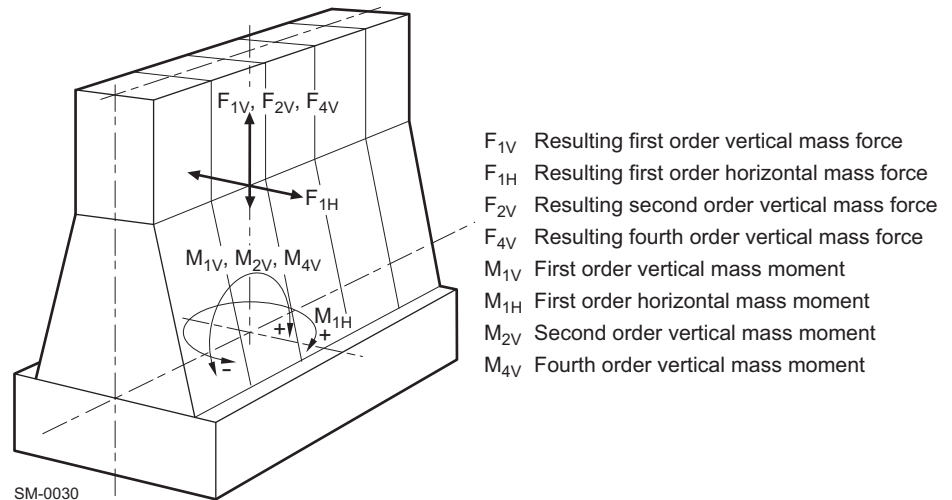

Figure 6-1 External mass forces and moments

Figure 6-1 shows the mass forces and moments generated by the engine. However, where possible these are neutralised. If not, cyclical generation of the external mass forces and moments may lead to unwanted and disturbing vibrations throughout the vessel. This highlights the importance of using countermeasures that balance out the generated mass forces and moments where possible.

6.1.1 Balancing of mass forces and moments

Forces

With a regular firing order of evenly distributed crank angles, an engine will inherently balance the summation of all vertical (F_V) and horizontal (F_H) free forces. Sometimes the firing order is designed to be irregular, i.e. unevenly distributed crank angles, to optimise the overall vibration characteristic of a specific engine type. Regardless, the resulting mass forces are considered to be negligible.

First order moments

First order mass moments (M_{1V} and M_{1H}) can be reduced to acceptable levels by introducing standard counterweights, fitted to the ends of the crankshaft. In special cases non-standard counterweights can be used to reduce either vertical (M_{1V}) or horizontal (M_{1H}) first order mass moments as required.

Standard counterweights fitted to the ends of the crankshaft reduce the first order mass moments to acceptable limits. However, in special cases non-standard counterweights can be used to reduce either M_{1V} or M_{1H} .

Second and fourth order moments

Second (M_{2V}) and fourth (M_{4V}) order vertical mass moments are also generated, although these magnitudes will vary depending on engine type and number of cylinders. Unless a problematic vessel design leads to unfavourable vibration, there is normally no cause for concern for engines with 7 cylinders or more. However, 6-cylinder engines are known to generate high magnitudes of unbalanced second order vertical mass moments (M_{2V}) and should therefore be carefully considered. Consequently, for 6-cylinder engines WinGD strongly recommends that the impact of the second order vertical mass moment on the vessel is carefully checked. In cases where the investigation reveals a possible problem, WinGD recommends to consider the installation of one of the following countermeasures, designed to reduce the effects of second order vertical mass moments to acceptable values.

6.1.2 Countermeasure for second order vertical mass moments*Electrically-driven compensator (external compensator)*

If disturbing second order vibrations occur on 6-cylinder engines, WinGD strongly recommends that an electrically-driven compensator is fitted or retro-fitted to the ship's structure. As seen in [Figure 6-2](#), such a compensator is usually installed in the steering gear compartment. It is tuned to the engine operating speed and controlled accordingly.

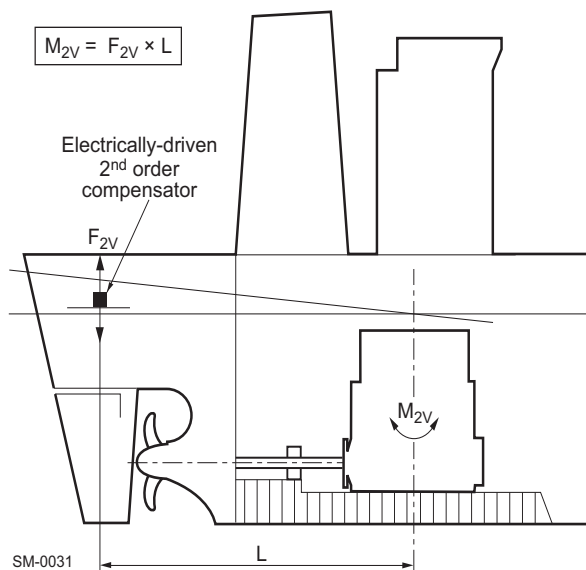
**Figure 6-2 Locating an electrically-driven compensator**

This countermeasure should also be considered for other cylinder number engines if the second order vertical mass moments (M_{2V}) surpass the necessary limits. However, suitability will vary for different engines and vessel design.

Power related unbalance

The power related unbalance (PRU) values can be used to estimate the risk of unacceptable levels of hull vibrations caused by external mass moments of first and second order. The PRU is calculated with the following formula:

$$PRU = \frac{M_x (Nm)}{Engine\ Power (kW)}$$

Formula 6-1 Power related unbalance calculation

where:

PRU = power related unbalance

M_x = M_{2V} (typically), M_{1H} & M_{1V} (considered as well)

The M_x and the resulting PRU values of an engine are dependent on the number of cylinders.



The resulting PRU values are graphically displayed in the link below, along with the likelihood of needing a compensator.

External forces and moments

The link provides dynamic characteristics data for engines tuned at R1 rating. For other engine speeds, the corresponding external mass moments are calculated with the following formula:

$$M_{x(CMCR)} = M_{x(R1)} \cdot \left(\frac{n_{CMCR}}{n_{R1}} \right)^2$$

Formula 6-2 External mass moments calculation for R_x rating

where:

$M_{x(CMCR)}$... = resulting moments for a specific engine’s CMCR

$M_{x(R1)}$ = moments for engine at R1 rating

n_{CMCR} = speed of engine for a specific engine’s CMCR

n_{R1} = speed of engine at R1 rating

6.2 External lateral forces and moments

The external lateral forces and moments (lateral engine vibrations resulting in 'rocking') are generated by the combustion process and to a small extent by the reciprocating masses of the running gear. The lateral forces depend on the CMCR and engine speed.

- F_G = Gas force
- F_P = Piston force
- F_C = Connecting rod force
- F_L = Lateral force
- F_R = Radial force
- F_T = Tangential force

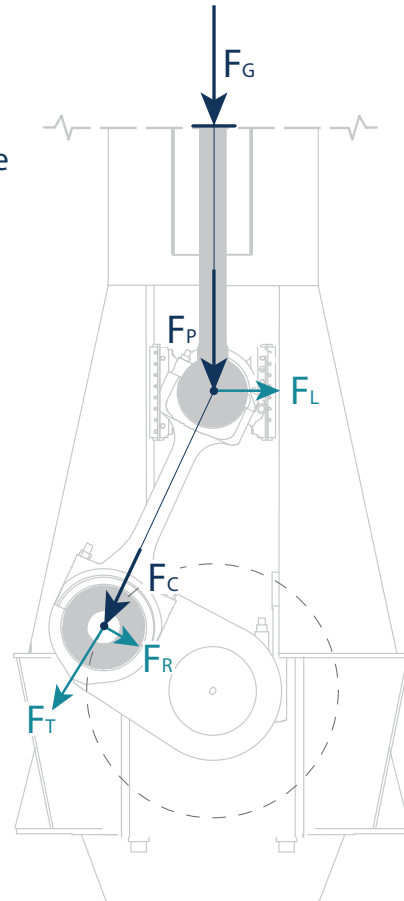

SM-0514

Figure 6-3 Forces through the engine

The forces between the piston and the connecting rod reaction cause a lateral force to act on the crosshead guide rails. The lateral forces at the guide rails are transmitted to the engine block and to the foundation.

The resulting lateral forces and moments may excite resonances of the combined engine and foundation system. In addition, hull resonances or local vibrations in the engine room may be generated.

6.2.1 Lateral vibration types

The resulting lateral forces and moments generate two different modes of lateral engine vibration, the H-type and X-type vibration; refer to [Figure 6-4](#).



The table of H-type and X-type vibration values is also provided in the link below:

[External forces and moments](#)

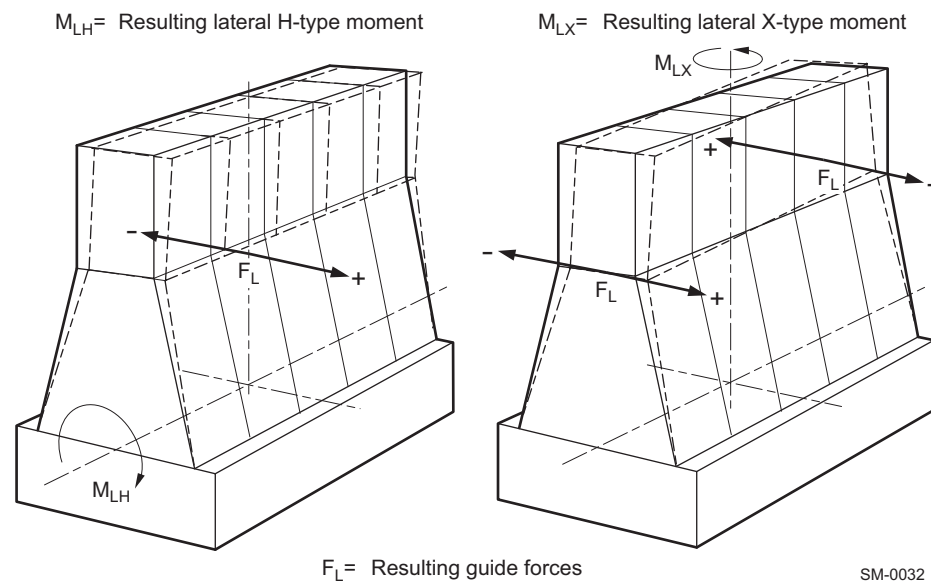

SM-0032

Figure 6-4 Lateral vibration — X-type and H-type

H-type vibration

H-type lateral vibrations are characterised by a mode shape where both sides of the top of the engine, the driving and free end, vibrate together, in phase. The lateral guide forces (F_L) result in a lateral moment, expressed as resulting lateral H-type moment (M_{LH}).

X-type vibration

X-type lateral vibrations are characterised by a mode shape where at the top of the engine, the driving and free ends vibrate in counter-phase to each other. As these resulting lateral guide forces create opposing axial moments at the two ends of the engine, the X-type lateral vibrations are expressed as a moment around the vertical axis, the resulting lateral X-type moment (M_{LX}).

6.2.2 Reduction of lateral vibration

The amplitudes of the vibrations transmitted to the hull depend on the design of the engine seating, frame stiffness and exhaust pipe connections. As the amplitude of the vibrations cannot be predicted with absolute accuracy, the support to the ship's structure and the space required to install the stays must be considered in the early design stages of the engine room structure. This is true for both lateral and longitudinal vibrations, which are further discussed along with relative reduction methods in the subsections that follow.

NOTE

WinGD recommends a stiff engine foundation design in the longitudinal and lateral directions, as this is always best practice in minimising hull vibrations.

Lateral stays

If required, lateral stays (i.e. stays in the lateral direction) must be fitted between the upper engine platform and the ship hull to prevent harmful resonance conditions. The main function of lateral stays is to shift the resonance frequency sufficiently above nominal speed as shown in [Figure 6-5](#).

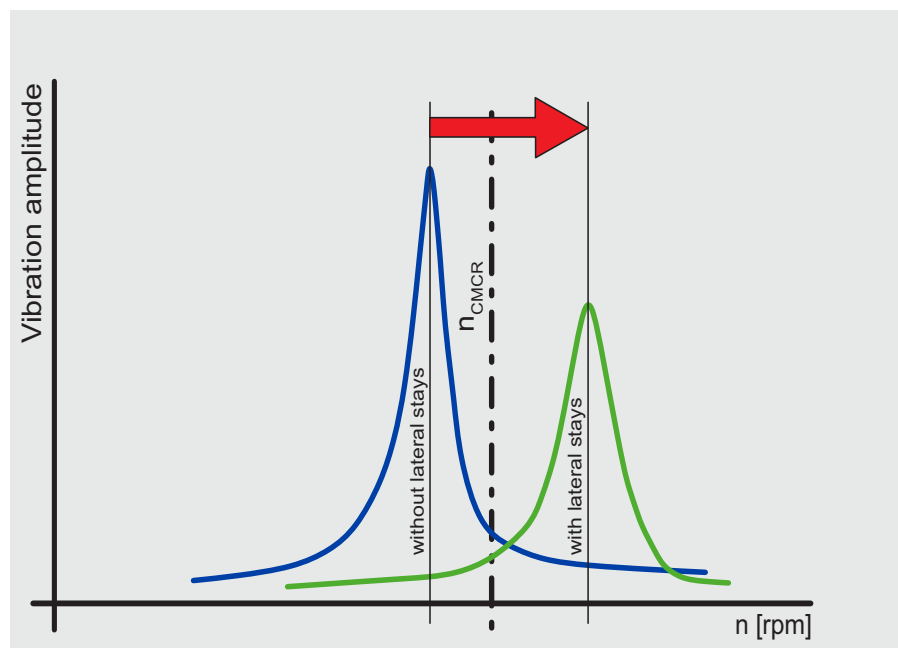

SM-0794

Figure 6-5 Lateral stays shifting the resonance frequency above nominal speed

NOTE

If lateral stays are required, WinGD requests installation of hydraulic type stays. These are available from third-party suppliers.

In addition, if hydraulic type stays are installed, as requested by WinGD, then a damping effect is provided by these stays.

Such hydraulic type stays can be either for both-side or one-side installation:

- Hydraulic type stays for one-side installation have two oil chambers (one on each side of the piston) and provide in this regard a 'damping effect' in both directions.
- Hydraulic type stays for both-side installation have an oil chamber on one side of the piston and an air chamber on the other side. The air chamber provides little to no damping effect.

The two general arrangements for both stay types are shown below in [Figure 6-6](#) and [Figure 6-7](#).

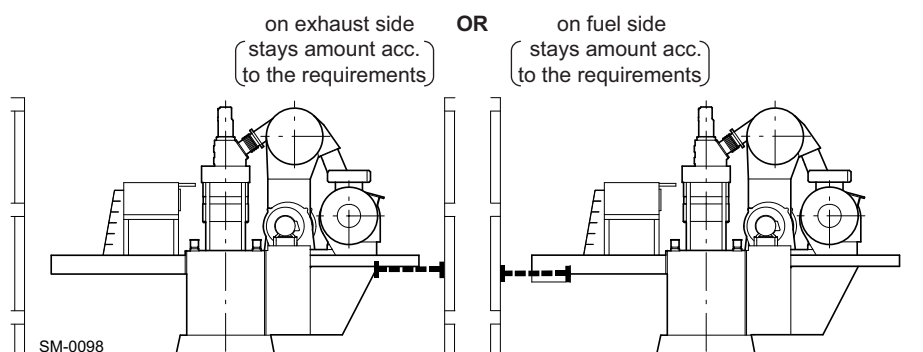

Figure 6-6 General arrangement of hydraulic type stays for one-side installation

NOTE

The selected hydraulic type stays must be suitable for one-side installation on the engine. The suitability of one-side installation must be confirmed by the hydraulic type stay supplier.

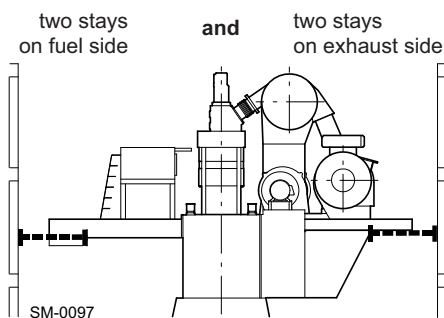

Figure 6-7 General arrangement of hydraulic type stays for both-side installation

Determining the minimum number of required lateral stays

On a scientific basis, the only way to determine the minimum number of required lateral stays (i.e. stays in the lateral direction) is by finite element calculation. This calculation takes into account the exact mass and stiffness properties of the foundation, as well as the aft section of the ship. This dynamic finite element investigation must be executed by the shipyard or a design institute. WinGD does not have these ship hull properties available to perform this extensive investigation.

However, based on broad experience with different bore sizes, cylinder numbers, and engine ratings, WinGD provides an alternative approach to determining the minimum number of required lateral stays. WinGD provides the magnitude of the lateral forces and moments resulting from the engine operation at R1 (as shown in *External forces and moments*). Project-specific values are available upon request. The magnitude of the lateral forces and moments is key for determining the minimum number of required lateral stays. Based on individual experience, engine builders and shipyards are free to select a different number of lateral stays.

From the project-specific external forces and moments, the values to consider are the lateral H-type moment (M_{LH}) and the lateral X-type moment (M_{LX}) which, without stays, have a resonance with inadmissible amplitude in the speed range of 70 to 110% of CMCR speed (n_{CMCR}).

Although there may be engines with high lateral excitations displayed on paper, these high values may not be relevant due to a missing resonance condition, and therefore, no stays are required. For example, most of the 7-cylinder engines do not require any lateral stays. This is mainly due to (a) the strong M_{LX} Ord.4 resonance which is located sufficiently above the CMCR speed (n_{CMCR}) and (b) the strong M_{LH} Ord.7 resonance which is located at low speed.

On the other hand, based on experience, most 8-cylinder engines are known to have a very strong M_{LX} Ord.5 resonance which is located close to the CMCR speed (n_{CMCR}), and therefore, lateral stays are mandatory. The same is applicable for 9-cylinder engines that also have a very strong M_{LX} Ord.6 resonance which is located slightly above the CMCR speed (n_{CMCR}).

On twin-engine installations, the lateral stays must be attached on the outboard side of the engines towards the ship hull. Depending on whether the engine is a standard or a left engine (see [Figure 6-8](#), [6-10](#) and [Figure 6-9](#), [6-10](#)), the outboard side can be on the fuel side or the exhaust side.

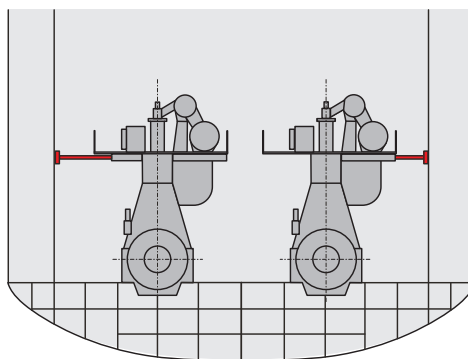

Installation of lateral stays on the fuel and exhaust side with:
Two STANDARD engines

SM-0795

Figure 6-8 Twin-engine installations with two standard engines

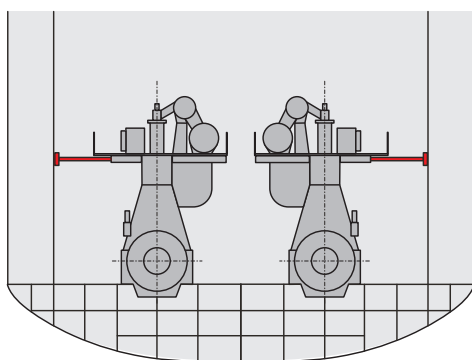

Installation of lateral stays on the fuel side with:
A STANDARD engine on the port side and
a LEFT engine on the starboard side

SM-0796

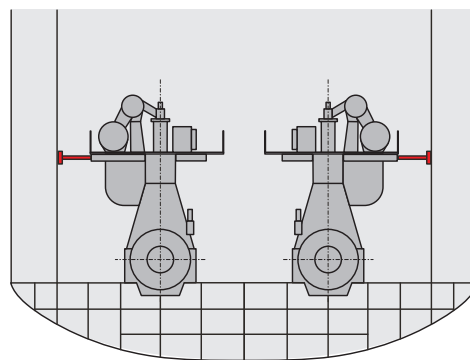

Installation of lateral stays on the exhaust side with:
A LEFT engine on the port side and
a STANDARD engine on the starboard side

Figure 6-9 Variants of twin-engine installations with a standard and a left engine

As shown in [Figure 6-10](#), [6-11](#), [Figure 6-11](#), [6-11](#), and [Figure 6-12](#), [6-12](#), WinGD recommends a specific number of lateral hydraulic type stays for installation on:

- The engine's exhaust side or
- The engine's fuel side or
- Both engine sides

NOTE

It must be ensured that the iCER return pipes do not conflict with the installation of the lateral stays on the exhaust side. Also, the iCER return pipes must not conflict with any of the engine pipe connections on the exhaust side. Alternatively, lateral stays must be installed on the fuel side.

As the project-specific design of the ship hull and engine foundation may vary in some cases, a different number of hydraulic type stays may be required. The final number of required lateral stays must be specified by the shipyard (e.g. based on experience or on sea trial test results).

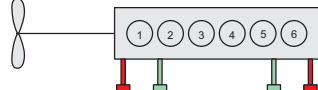
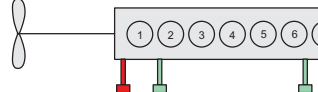
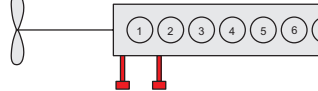
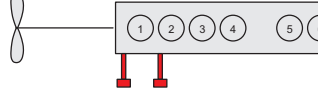
No. of cyl.	Available attachment points on the platform of the engine's exhaust side	Recommended number of stays
6		<p>■ Recommended: 2</p> <p>■ Optional: +2</p>
7		<p>■ Recommended: 2*</p> <p>■ Optional: +2</p> <p>* Usually no stays are required for 7 cyl.</p>
8		<p>■ Recommended: 4</p> <p>■ Optional: -</p>
9		<p>■ Recommended: 4</p> <p>■ Optional: -</p>

SM-0782

Figure 6-10 Engine stays arrangement on the exhaust side

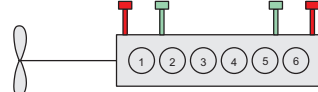
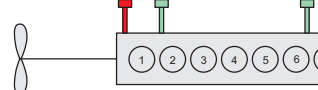
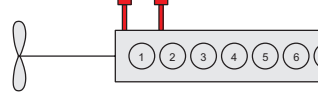
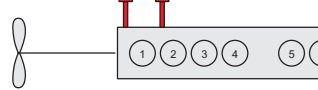
No. of cyl.	Available attachment points on the platform of the engine's fuel side	Recommended number of stays
6		<p>■ Recommended: 2</p> <p>■ Optional: +2</p>
7		<p>■ Recommended: 2*</p> <p>■ Optional: +2</p> <p>* Usually no stays are required for 7 cyl.</p>
8		<p>■ Recommended: 4</p> <p>■ Optional: -</p>
9		<p>■ Recommended: 4</p> <p>■ Optional: -</p>

SM-0783

Figure 6-11 Engine stays arrangement on the engine's fuel side

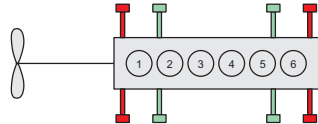
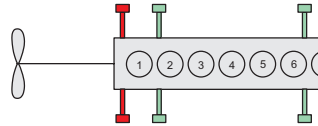
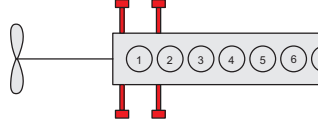
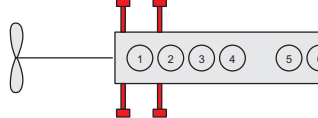
No. of cyl.	Available attachment points on the platform of the engine's fuel and exhaust side	Recommended number of stays
6		<p>■ Recommended: 4</p> <p>■ Optional: +4</p>
7		<p>■ Recommended: 4*</p> <p>■ Optional: +4</p> <p>* Usually no stays are required for 7 cyl.</p>
8		<p>■ Recommended: 8</p> <p>■ Optional: -</p>
9		<p>■ Recommended: 8</p> <p>■ Optional: -</p>

SM-0784

Figure 6-12 Engine stays arrangement on both engine sides

Electrically-driven compensator(s)

If lateral stays cannot be installed, electrically-driven compensators are available to reduce lateral engine vibrations:

- For H-type vibration:
 - One electrically-driven compensator can be installed in the longitudinal centre point of the engine
 - Two phase-synchronised electrically-driven compensators can be applied, one at each end of the engine
- For X-type vibration:
 - Two counterphase-synchronised electrically-driven compensators are necessary, one at each end of the engine

NOTE

Project-specific engine reinforcements must be approved by WinGD prior to installation.

It must be noted that electrically-driven compensators can only compensate one harmonic excitation frequency at a time.

6.3 Longitudinal vibration (pitching)

NOTE

As longitudinal vibration is insignificant for this type of engine, no countermeasures are required.

6.4 Torsional vibration

Torsional vibrations are generated by gas and inertia forces as well as by the irregularity of the propeller torque. It does not cause hull vibration (except in very rare cases) and is not perceptible in service, but produces additional dynamic stresses in the shafting system.

The shafting system comprises of the crankshaft, propulsion shafting, propeller, engine running gear, flexible couplings, and power take-off (PTO). The complete assembly of the shafting system must be considered when determining the torsional loads in the system components.

Torsional vibration calculation (TVC)

The torsional loads in the system components are determined by performing a torsional vibration calculation (TVC). The TVC must be done in the early stage for every project.

Across the engine's speed range, all system components must remain within their corresponding torsional vibration load limits. If in a component, the torsional loads exceed the corresponding limit, appropriate countermeasures have to be applied.

The calculation normally requires approval by the relevant classification society and may require verification by measurement on board ship during sea trials. All data required for torsional vibration calculations should be made available to the engine supplier in an early design stage (see section 6.9, [6-23](#)).

Barred speed range (BSR)

At a certain speed range the torsional vibration stresses in the shafting may exceed the limits for continuous operation. If this occurs, a barred speed range (BSR) must be defined. The width of the BSR is defined by the classification society. The BSR must be passed through rapidly and some classification societies have defined rules about the maximum permissible passage time through the BSR. In general, the target is to have a maximum passage time of 30 seconds.

In order to guarantee a rapid passage of the BSR, a minimum power margin of 10% at the upper boundary of the BSR must be present. The power margin is defined as the margin between the bollard pull curve and the engine torque limit.

In any case, within the BSR the torsional shaft stress must not exceed the transient limit, otherwise other appropriate countermeasures have to be taken.

6.4.1 Reduction of torsional vibration

Excessive torsional vibration can be reduced by optimising the shaft diameters, selecting a different (heavier) flywheel, adding a front disc (tuning wheel) to the free end of the crankshaft or adding a torsional vibration damper to the free end of the crankshaft. A torsional vibration damper reduces the torsional stresses by absorbing part of the vibration energy.

Viscous damper*Low-energy vibrations*

Where low-energy torsional vibrations have to be reduced, a viscous damper can be installed (see [Figure 6-13](#), [Figure 6-15](#)). In some cases, the torsional vibration calculation shows that an additional oil-spray cooling for the viscous damper is needed. In such cases the layout must be in accordance with the recommendations of the damper manufacturer and WinGD design department. The viscosity of the silicone oil in the viscous damper must be checked periodically. The interval is specified by the damper manufacturer. For more information, refer to the Operation Manual.

High-energy vibrations

For high-energy torsional vibrations that may occur e.g. on 6-cylinder engines, a spring type damper with its damping effect may be considered (see [Figure 6-13](#), [Figure 6-15](#)).

Spring damper

The spring damper must be supplied with oil from the engine's lubricating oil system. Depending on the torsional vibration energy to be absorbed, the damper can dissipate up to 80kW of energy (this will be based on the number of cylinders).

Depending on the installed spring damper, the initial estimated oil flow to the spring damper is approximately 30m³/h. However, the project-specific oil flow must be provided by the spring damper designer. This project-specific oil flow must be based on the final torsional vibration calculation results.

NOTE

For Geislinger spring dampers, the initial estimated oil flow to the spring damper as well as the project-specific oil flow are provided with a tolerance of ±50%.

In case of uncertainty with regards to the oil flow, WinGD recommends installing the main lubricating oil pumps with a higher flow capacity margin. The arrangement of the lubricating oil system (see [Figure 4-24](#), [Figure 4-41](#)) enables return of excessive oil supply to the lubricating oil drain tank. This is achieved through a pressure retaining valve.

NOTE

For spring damper installation, the application of a damper monitoring system is mandatory.

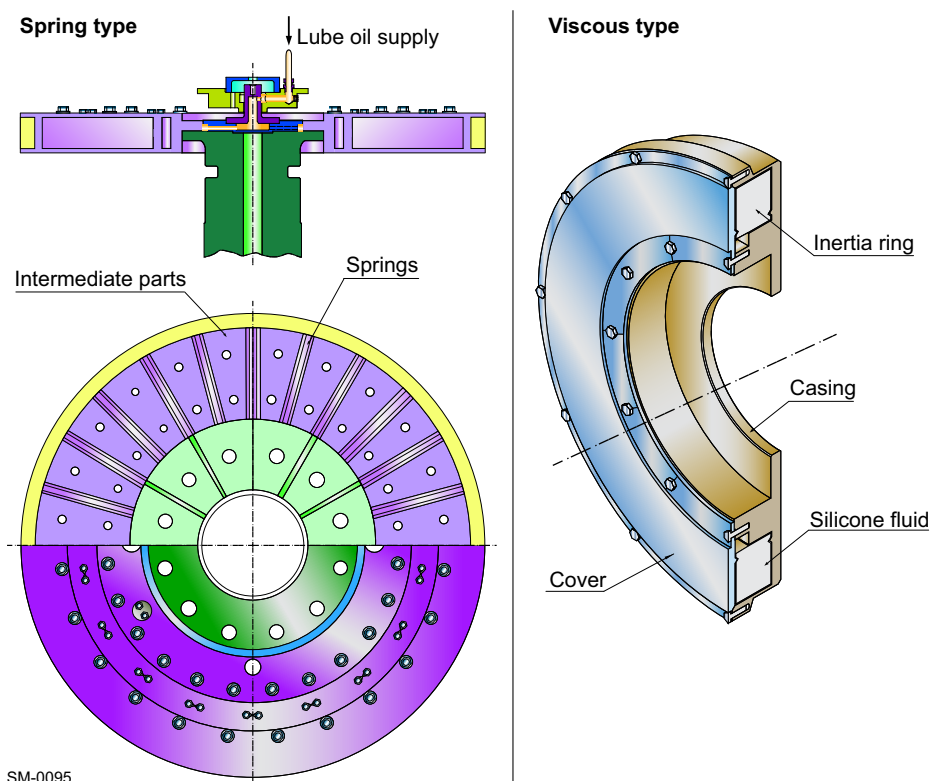

Figure 6-13 Vibration dampers (spring type and viscous type)

6.4.2 PTO/PTI systems effect on torsional vibration

A propulsion plant may include a main engine-driven generator (PTO, power take-off), a shaft-line connected electric motor (PTI, power take-in), or both. These elements are connected to the engine or shafting by clutches, gears, shafts and/or elastic couplings (see Figure 4-70, 4-125 for the different arrangements).

Installations with PTO or PTI require special attention in the early stages of a project. These systems may cause torsional vibrations and alignment challenges.

Risk of unstable engine speed

For many PTO / PTI systems that use elastic couplings, the lowest torsional natural frequency can be problematic if it is below approximately 1.5 Hz. Here, there is a risk of engine speed instability where the engine constantly adjusts its speed to compensate the rotating vibration; this must be considered and compensated for in the engine speed control system.

Installation of MFD

In addition, such PTO / PTI systems are very sensitive to misfiring as varying firing loads can cause inadmissible torsional vibrations. To protect the elastic couplings and gears from any misfiring, a misfiring detection device (MFD) must be installed. This indicates either partial or total misfiring, allowing for appropriate countermeasures (e.g. speed reduction, de-clutching of PTO / PTI branch) to be applied automatically, protecting the PTO / PTI components.

For additional consideration about PTO / PTI application refer to section 4.13, 4-124, and for support regarding system layout, please contact WinGD.

6.5 Axial vibration

The axial vibrations mainly depend on the dynamical axial system of the crankshaft, the mass of the torsional vibration damper, and any free-end installations or flywheel fitted to the crankshaft. Additionally, axial vibrations can be considerably influenced by torsional vibrations. This influence is called *coupling effect*.

It is recommended that axial vibration calculations are carried out at the same time as torsional vibration calculations. To consider the coupling effect of torsional vibrations on axial vibrations, it is necessary to apply a suitable coupled axial vibration calculation method.

As the shafting system is made up of masses and elastic connections, it is capable of vibrating and resonating at several frequencies. This would result in excessive stress in the crankshaft and in some cases can lead to excessive vibration of the upper part of the engine.

Reduction of axial vibration

Axial vibration damper

To limit the influence of axial excitations and reduce the level of vibration, all present WinGD engines are equipped with an integrated axial vibration damper. In most cases, this lowers the axial vibrations in the crankshaft to acceptable values, meaning no further countermeasures are required. No excessive axial vibrations occur, neither in the crankshaft, nor in the upper part of the engine.

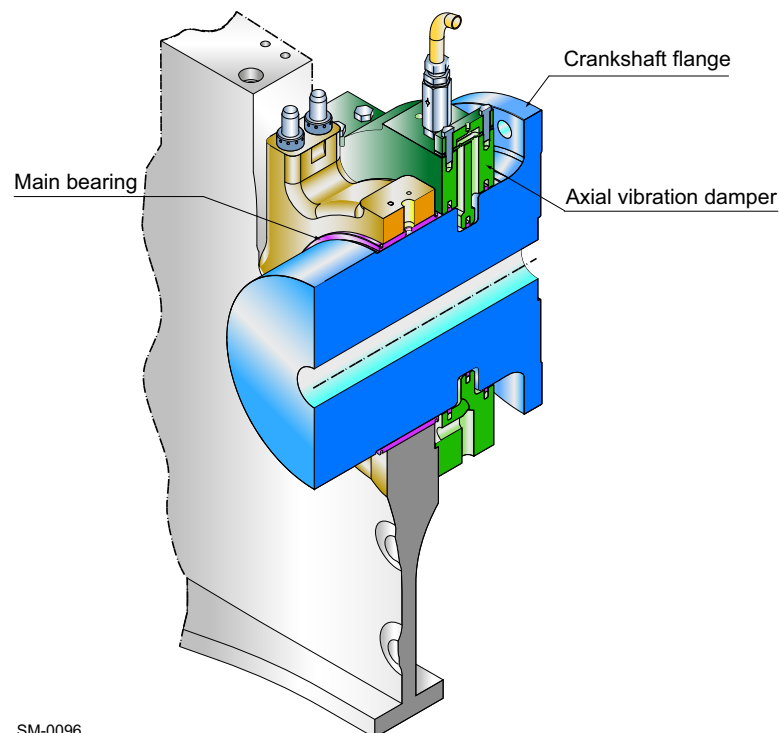

Figure 6-14 Example of axial vibration damper

The integrated axial vibration damper is mounted at the free end of the crankshaft. It is connected to the main lubricating oil circuit. An integrated oil pressure monitoring system continuously checks the correct operation of the axial vibration damper.

6.6 Whirling vibration

Whirling vibrations are generated when the shaft rotates and goes into transverse oscillations. If the shaft is out of balance, the resulting centrifugal forces will induce the shaft to vibrate. This vibration is commonly known as *whirling vibration*, *bending vibration* or *lateral shaft vibration*.

Whirling vibrations are in most cases not relevant in propulsion shafting with directly coupled low-speed 2-stroke engines. Typically, whirling vibrations are only relevant in 2-stroke installations having a very long shaft line (longer than 60m).

Many classification societies do not require whirling vibration calculations for installations with low-speed 2-stroke engines. In general, only the natural whirling frequencies are calculated. The number and position of the shaft bearings have a significant influence on the natural frequencies. As such, the whirling vibration calculation must be performed after or together with the alignment calculation.

Alignment Guidelines for Layout Calculation

6.7 Hull vibration

The hull and accommodation area are susceptible to vibration caused by the propeller, machinery and sea conditions. Controlling hull vibration from engine excitation is achieved by a number of different means and may require the fitting of second order mass moment compensators, lateral/longitudinal stays, electrical H-type or X-type compensators and/or torsional vibration dampers.

Avoiding problematic hull vibrations cannot be achieved in isolation and requires consideration and cooperation from propeller manufacturer, naval architect, shipyard, and engine builder.

WinGD can provide, on request, a simplified FE engine model to enable the shipyard or design institute to predict the influence of the engine forces and moments on the ship hull.

6.8 Countermeasures for dynamic effects

6.8.1 External mass moments and vibrations

The following tables indicate where dynamic effects and the countermeasures required to reduce them are to be given special attention.

Where installations incorporate PTO arrangements (see [Figure 4-70](#), [4-125](#)), further investigation is required and WinGD should be contacted.

Table 6-1 Countermeasures for external mass moments

No. of cyl.	Second order compensator
6	Balancing countermeasure is likely needed ^{a)}
7-9	Balancing countermeasure is not relevant

a) No engine fitted second order balancer available. If reduction in M_{2V} is needed, then an external second order compensator has to be applied.

Table 6-2 Countermeasures for lateral and longitudinal vibrations

No. of cyl.	Lateral stays	Longitudinal stays
6-7	B ^{a)} / A ^{b)}	C
8	A	C
9	B	C

A = The countermeasure indicated is needed.
 B = The countermeasure indicated may be needed and provision for the corresponding countermeasure is recommended.
 C = The countermeasure indicated is not needed.

a) 'B' for $n_{cmcr} \leq 74$ rpm

b) 'A' for $n_{cmcr} > 74$ rpm

Table 6-3 Countermeasures for torsional and axial vibrations of the shafting

No. of cyl.	Torsional vibration	Axial vibration
6-9	Detailed calculations have to be carried out for every installation; countermeasures to be selected accordingly (shaft diameters, critical or barred speed range, flywheel, tuning wheel, torsional vibration damper).	An integrated axial vibration damper is fitted as standard to reduce the axial vibration in the crankshaft. However, the effect of the coupled axial vibration on the propulsion shafting components should be checked by calculation.

6.8.2 Synchro-Phasing System in twin engines

An available countermeasure for vibration reduction in twin engine vessels is WinGD’s Synchro-Phasing System (SPS). By changing the relative phase difference of the two engines operating with the same speed, it is possible to neutralise vibrations of a selected frequency and the resulting resonance on the ship’s hull or structure.

Synchro-Phasing can be an effective way of reducing vibrations without modifications to the ship’s structure and with limited cost.

Concept

As discussed previously in this section, it is important that vibrations of the engine or propeller are minimised. Some specific vibrations will be problematic if they cause resonance in the surrounding vessel structure.

Alteration of phase angles

With twin-engine vessels the resulting vibration amplitude is equal to the sum of both engines and is therefore dependent on the phase difference of the engines. The phase difference of any two vibrations is the relative difference (of angle or time) between any matching points of their vibrational cycles.

It is shown in [Figure 6-15](#) that if the vibrations are in phase (0° phase difference) the resultant amplitude can reach double that of a single vibration. However, towards a phase difference of 180° the amplitude is reduced from the vibrations neutralising each other.

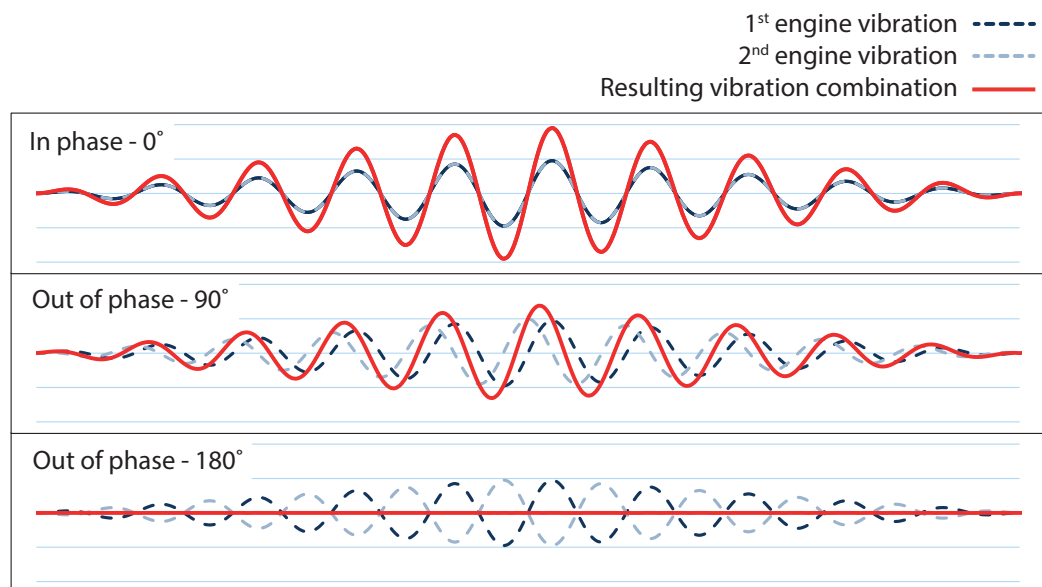

SM-0515

Figure 6-15 Resulting vibration from SPS combinations

By correctly altering the phase angles between two crankshafts, a vibration can be reduced and possibly eliminated, limiting vibrations distribution in the ship’s hull and superstructure.

SPS is used to compensate one of the following:

- Second order vertical mass moments (M_{2V}) discussed in section 6.1, 6-2
- Lateral H-type guide moments discussed in section 6.2, 6-5
- Excitations generated by the blade frequency of the propellers

NOTE

The compensation is only capable of neutralising one selected frequency at a time.

Components and control

The speed and the crank angle of both engines are measured by control units, which are installed on the engines. These signals are continuously transmitted to the Synchro-Phasing main controller, where the relative position and speed between the two engines is measured.

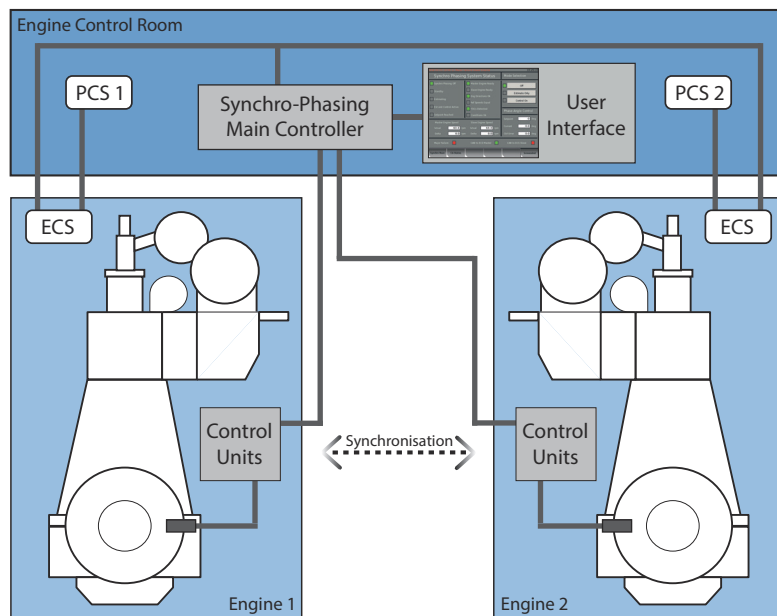

SM-0516

Figure 6-16 Synchro-Phasing system

Main controller and user interface in ECR

The main controller is installed in the engine control room along with the user interface, where the relative phase difference angle (provided by WinGD vibration experts) can be entered. This enables the system to implement a closed loop control of the set-points, which are a function of the difference between the reference phase angle and current phase angle. To adjust the phase angle between the two engines, the speed of only one (slave) engine is adapted.

The additional components required are:

- Control unit (x2)
- Synchro-Phasing main controller (x1)
- User interface (x1)

NOTE

Any phase angle value entered into the user interface must be previously approved by WinGD's Dynamics experts, as incorrect settings can lead to excessive vibrations.

Operating modes and restrictions

There are three operating modes:

- **Control On**
Fully operational. This can be selected when the release conditions are fulfilled (see in the following).
- **Estimate Only**
The speed of each engine and the relative phase angle between them is indicated and continuously updated, but not controlled. This can be selected when the release conditions are fulfilled (see below).
- **Off**
All control parameters of Synchro-Phasing control are reduced and reset to initial value (zero). This can be selected at any time.

Release conditions

The following conditions must be fulfilled to activate the **Control On** and **Estimate Only** modes. These conditions are:

- Both engines are running in ahead direction in normal operational condition and unrestricted operation conditions (no protective actions of the engine or major failures)
- Both engines are operated within the speed conditions of the Synchro-Phasing system
- Heavy Sea Mode is not active on either engine
- No major failure of phase angle control system is active
- Both engines have the same speed set-point and have completed the load up/down programs to reach this speed set-point

Deactivation of the **Control On** and **Estimate Only** modes will occur if required. Synchro-Phasing is also overruled and reset if engine limitations are reached. After deactivation, **Off** will be automatically active.

6.9 Order forms for vibration calculation & simulation



WinGD provides additional support services to assist with system dynamics and vibration analysis. All questionnaires and forms can be downloaded from the WinGD webpage under the following link:

[*Questionnaires for shaft calculations*](#)

Forms should be filled in and submitted via e-mail to the following e-mail address, along with any further questions:
dynamics.ch@wingd.com

Winterthur Gas & Diesel Ltd.
Engine Dynamics
Schützenstrasse 3
8400 Winterthur
Switzerland

7 Engine Emissions

In 1973, an agreement on the International Convention for the Prevention of Pollution from Ships (ICPPS) was reached. It was modified in 1978 and is now known as MARPOL 73/78.

MARPOL 73/78 Annex VI (also known as MARPOL Annex VI), came into effect in 2005 and contains regulations limiting or prohibiting certain types of emissions from ships, including limitations with respect to air pollution. MARPOL Annex VI is continuously amended. Recently a revised and updated version was published as IMO resolution MEPC.328(76) and came into effect in November 2022.

7.1 Exhaust gas emissions

Major exhaust gas emissions include oxides of carbon (CO and CO₂), oxides of nitrogen (NO and NO₂), oxides of sulphur (SO₂ and SO₃) and Particulate Matter (PM). Exhaust gas emissions are a critical topic of interest in the shipping industry.

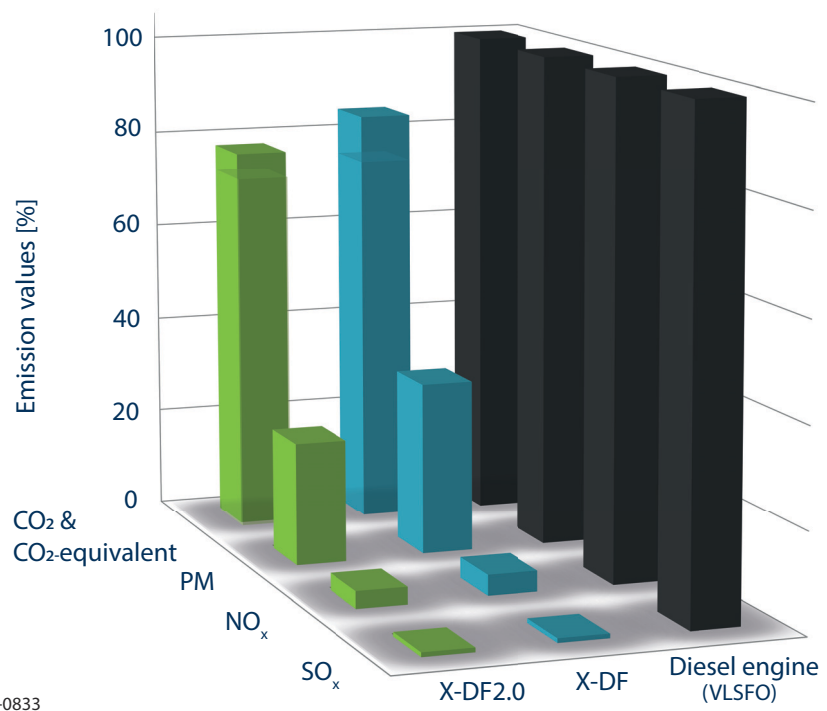

Figure 7-1 Emissions comparison between X-DF2.0, X-DF and diesel engines

As shown in [Figure 7-1](#), X-DF engine emissions are significantly reduced compared to diesel engines. These reductions are mainly related to the engine technologies and different fuels. X-DF engines operate according to the Otto cycle combustion process, which contributes to the NO_x reduction. In addition, X-DF engines use LNG as the main fuel and this leads to a reduction of CO₂, CO₂ eq. (CO₂-equivalent), PM and SO_x. A further reduction in emissions is observed between X-DF and X-DF2.0 engines, related to the introduction of iCER technology.

7.1.1 Regulation and calculation criteria for NO_x emissions

Regulation 13 of MARPOL Annex VI specifies a limit for the nitrogen oxides (NO_x) emissions for engines installed on ships. This has a direct implication on the design of propulsion engines.

NO_x Technical Code

The rules and procedures for demonstrating and verifying compliance with Regulation 13 of MARPOL Annex VI are provided in the NO_x Technical Code, which is part of Annex VI and is largely based on the latest revision of ISO 8178.

NO_x Calculation criteria

Depending on the rated speed of the engine and the date of vessel keel-laying, the weighted average NO_x emission of the engine must not exceed the maximum allowable value as indicated by the respective curves in [Figure 7-2](#).

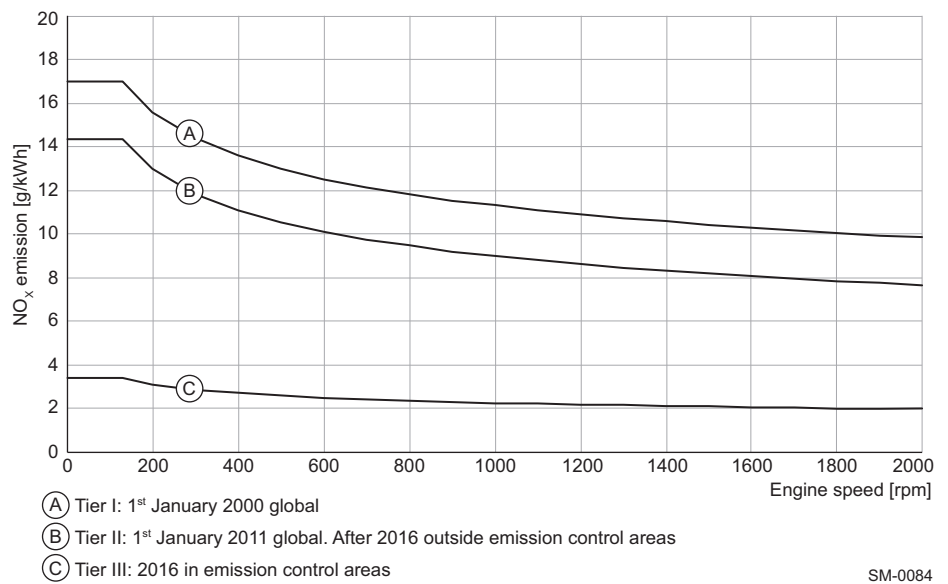

Figure 7-2 Speed dependent maximum allowable average of NO_x emissions

NO_x emissions can be calculated with the following conversion formula:

$$m_{NO_x} = NO_x \cdot \frac{P_{ME}}{1000}$$

Formula 7-1

where:

- m_{NO_x} = Nitrogen oxides emissions [kg/h]
- NO_x = Nitrogen oxides emissions [g/kWh]
- P_{ME} = Engine power [kW]

The NO_x in [Formula 7-1](#) is a project-specific value and it is a function of the engine type and power. The engine-specific values are available in the [GTD](#).

7.1.2 Regulation and calculation criteria for SO_x emissions

Regulation 14 of MARPOL Annex VI specifies the limits for SO_x. Such limits are specifically defined for designated Emission Control Areas (ECA) as well as globally. As shown [Figure 7-3](#), the ECA limit has been gradually reduced from its initial value of 1.5% to 1.0% (2010) and finally to 0.1% (2015). The global limit has also been gradually reduced from its initial value of 3.5% (2012) to 0.5% (2020).

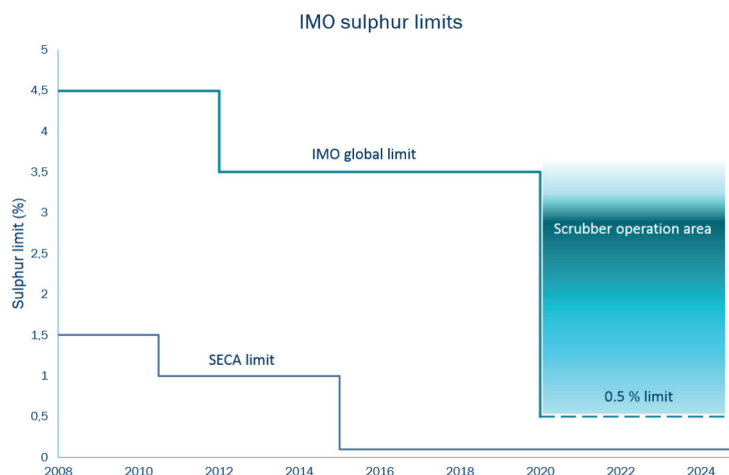

SM-0836

Figure 7-3 Sulphur limits introduced by IMO according to MARPOL Annex VI

SO_x Calculation criteria

Total SO_x emissions are linked mainly to two factors. The first factor is the sulphur content of the fuel, which must fulfill the requirements stated under Regulation 18 of MARPOL Annex VI. The second factor is the fuel consumption.

SO_x emissions (as SO₂) can be calculated with the following formula.:

$$m_{SO_x} = BSFC \cdot 2.0 \cdot \frac{SC}{100} \cdot \frac{P_{ME}}{1000}$$

Formula 7-2

where:

- m_{SO_x} = Oxides of sulphur emissions [kg/h]
- $BSFC$ = Brake Specific Fuel Consumption [g/kWh]
- 2.0 = Molar mass ratio of sulphur to sulphur dioxide
- SC = Sulphur Content [%]
- P_{ME} = Power (Main Engine) [kW]

BSFC is a function of the engine type and power. Project-specific values are available in the [GTD](#).

The actual Sulphur Content (SC) of the fuel is a value stated by the fuel oil supplier on the bunker delivery note.

The value for the molar mass ratio of sulphur to sulphur dioxide is assumed to be equal to 2.0 as the majority of SO_x emissions are SO₂. Assuming that 5% of SO_x emissions are SO₃, this factor would change to 2.03. This illustrates that the equation is a good approximation for the real exhaust gas emissions composition.

7.1.3 Regulation and calculation criteria for CO₂ emissions

The IMO strategy is to reduce CO₂ emissions for shipping by at least 40% by 2030 and a further reduction of up to 70% by 2050 (compared to the 2008 values). New amendments to MARPOL Annex VI came into effect on 1st November 2022. The new measures require all ships to calculate their Energy Efficiency Existing Ship Index (EEXI) and to establish their annual operational Carbon Intensity Indicator (CII) and CII rating.

CO₂ Calculation criteria

Currently, only CO₂ is considered in EEXI and CII. In the future, CO₂-equivalent may be included in the CII. However, WinGD already provides CO₂ and CO₂-equivalent emission data. The total amount of CO₂ emissions (known as CO₂-equivalent) is the sum of fuel combustion and methane slip emissions.

For engines operating in gas mode, the CO₂-equivalent can be calculated with the following formula:

$$m_{CO_2eq} = ((BSGC - CH_4) \cdot CF_{LNG} + BSPC \cdot CF_{MDO} + CH_4 \cdot GWP_{CH_4}) \cdot \frac{P_{ME}}{1000}$$

Formula 7-3

For calculation of the annual operational Carbon Intensity Indicator (CII), only the CO₂ emissions based on the fuel consumption must be considered:

$$m_{CO_2} = (BSGC \cdot CF_{LNG} + BSPC \cdot CF_{MDO}) \cdot \frac{P_{ME}}{1000}$$

Formula 7-4

where:

m_{CO_2eq} = CO₂-equivalent emissions [kg/h]

m_{CO_2} = CO₂ emissions [kg/h]

CH_4 = Methane slip [g/kWh]

$BSGC$ = Brake Specific Gas Consumption [g/kWh]

CF_x = Conversion Factor

$BSPC$ = Brake Specific Pilot Fuel Consumption [g/kWh]

P_{ME} = Engine Power [kW]

GWP_{CH_4} = Global Warming Potential value for methane

BSGC and BSPC depend on the engine type and rating. The project-specific values are available in the *GTD*.

CF is a non-dimensional conversion factor between fuel consumption and CO₂ emissions. CF has different values depending on the fuel type. The values can be found in resolution *MEPC.308(73)*.

The methane slip is a project-specific value and is a function of the engine type and power. The engine-specific values are available in the *GTD*.

The GWP for the CH₄ is a value estimated over a period of 20 or 100 years. For the CO₂ emissions calculation, WinGD suggests using a value of 28 which is the reference value for 100 years. The GWP factor is not yet implemented in the official regulations but may be considered for more accurate emissions calculations.

For engine operation in diesel mode, CH₄ values are irrelevant and CO₂-equivalent can be calculated with the following formula:

$$m_{CO_2eq} = (BSFC \cdot CF_{MDO} + BSPC \cdot CF_{MDO}) \cdot \frac{P_{ME}}{1000}$$

Formula 7-5

where:

m_{CO_2eq} = CO₂-equivalent emissions [kg/h]

$BSFC$ = Brake Specific Fuel Consumption [g/kWh]

CF_x = Conversion Factor

$BSPC$ = Brake Specific Pilot Fuel Consumption [g/kWh]

P_{ME} = Engine Power [kW]

7.1.4 PM emissions

Regulation 14 of MARPOL Annex VI specifies the limits for PM emissions, which are mainly related to unburned combustion residuals and fuel quality. An approximate reduction of 65% in PM emissions is achieved by X-DF engines compared to diesel engines, as LNG is considered a clean fuel and the combustion follows the lean burn Otto cycle. A further reduction of about 10% is achieved by X-DF2.0 engines compared to X-DF. The iCER system, with internal exhaust gas recirculation, contributes to further reduction in PM emissions (as shown in [Figure 7-1](#), [Fig 7-1](#)).

7.1.5 iCER diesel Tier III mode

This X-DF2.0 engine is available with the option of Tier III compliant operation by use of the iCER system (see [iCER operating mode options](#), [Fig 1-1](#)). This engine operation mode uses MGO fuel (with maximum 0.10% m/m sulphur). To achieve Tier III compliance in diesel mode operation, exhaust gas recirculation is used to reduce the NO_x emissions.

7.2 Engine noise

As the ship's crew/passengers must be protected from the effects of machinery space noise, the maximum acceptable noise levels are defined by rules. In general, for new building projects, the latest IMO Resolution MSC.337 'Code of Noise Levels Onboard Ships' is applied.

The main change introduced by the new IMO MSC.337, compared to the previous Resolution A468(XII), is that in large rooms with many measurement positions, the individual positions must be compared to the maximum admissible limit.

NOTE

The noise level graphs in [Figure 7-4](#), [7-7](#), [Figure 7-6](#), [7-9](#) and [Figure 7-7](#), [7-10](#) show typical values for MCR. As the rating dependency is marginal, the values can be used for all ratings.

7.2.1 Air-borne noise

[Figure 7-4](#), [7-7](#) shows the average surface sound pressure level. The data in the graph are related to:

- Distance of 1 m from engine
- Average values L_p in dB, in comparison with ISO NR-Curves
- Overall average values L_{pA} in dB(A) and expected maximal overall single point values
- Free field conditions

Near the turbocharger (air intake), the maximum measured noise level will normally be 3-5 dB(A) higher than the average noise level of the engine.

Standard noise reduction & additional noise reduction

The present document includes the expected maximum overall value for a single point. [Figure 7-4](#), [7-7](#) distinguishes between standard noise reduction and additional noise reduction on turbocharger air side. The turbocharger suppliers are currently developing different silencer solutions to comply with the new noise limit regulation of 110 dB(A) for single point.

NOTE

The single point noise limit of 110 dB(A) for machinery spaces may be exceeded if standard silencers are applied.

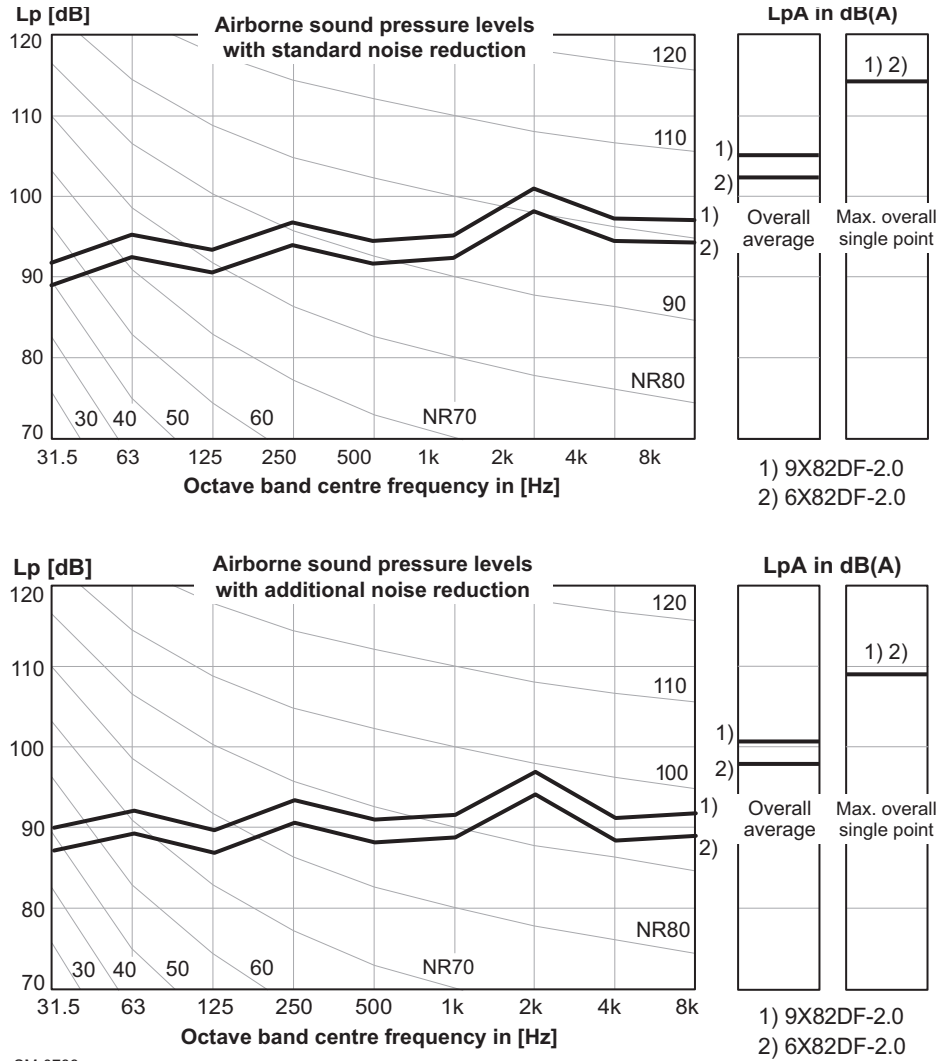

SM-0766

Figure 7-4 Sound pressure level at 1 m distance from engine

7.2.2 Exhaust noise

In the engine exhaust gas system, the sound pressure level at funnel top (see Figure 7-6, 7-9) is related to:

- Distance of 1 m from edge of exhaust gas pipe opening (uptake)
- Angle of 30° to gas flow direction (see Figure 7-5)
- Average values L_p in dB, in comparison with ISO NR-Curves
- Overall average values L_{pA} in dB(A)
- Without economiser, silencer, exhaust gas bypass

Each doubling of the distances from the centre of the duct reduces the noise level by about 6 dB.

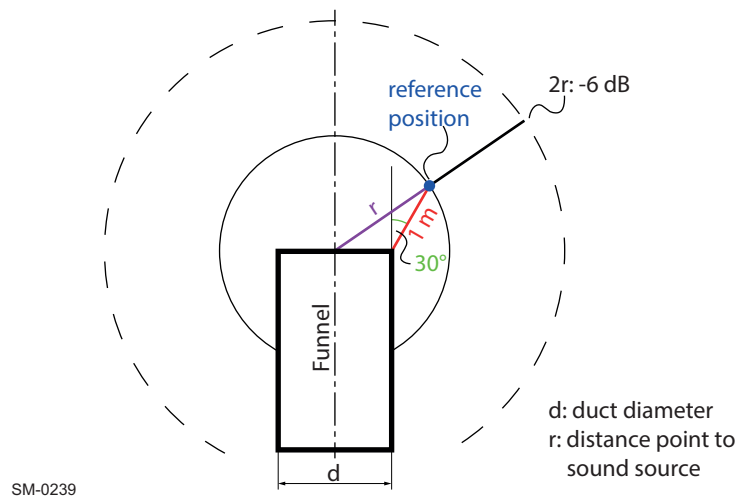

Figure 7-5 Exhaust noise reference point

Silencer after economiser

Depending on the actual noise level allowed on the bridge wing — which is normally between 60 and 70 dB(A) — a simple flow silencer of the absorption type may be placed after the economiser, if the noise reduction of the economiser is not sufficient.

Silencer in exhaust line

A silencer in the main engine exhaust line may be considered, as on the X-DF engines an exhaust gas bypass is installed by default.

Dimensioning

The silencers are to be dimensioned for a gas velocity of approx. 35 m/s with a pressure loss of approx. 2 mbar at specified CMCR.

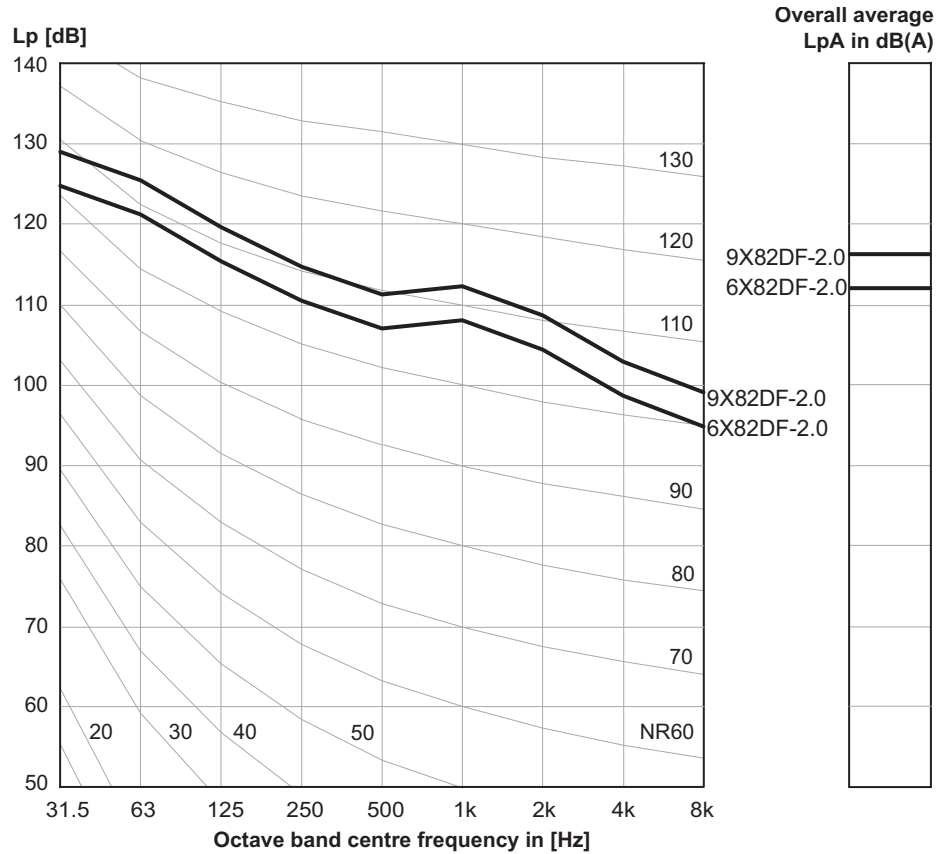

Figure 7-6 Sound pressure level at funnel top of exhaust gas system

SM-A767

7.2.3 Structure-borne noise

The vibrational energy is propagated via engine structure, bedplate flanges and engine foundation to the ship’s structure, which starts to vibrate and thus emits noise.

The sound pressure levels in the accommodations can be estimated with the aid of standard empirical formulas and the vibration velocity levels.

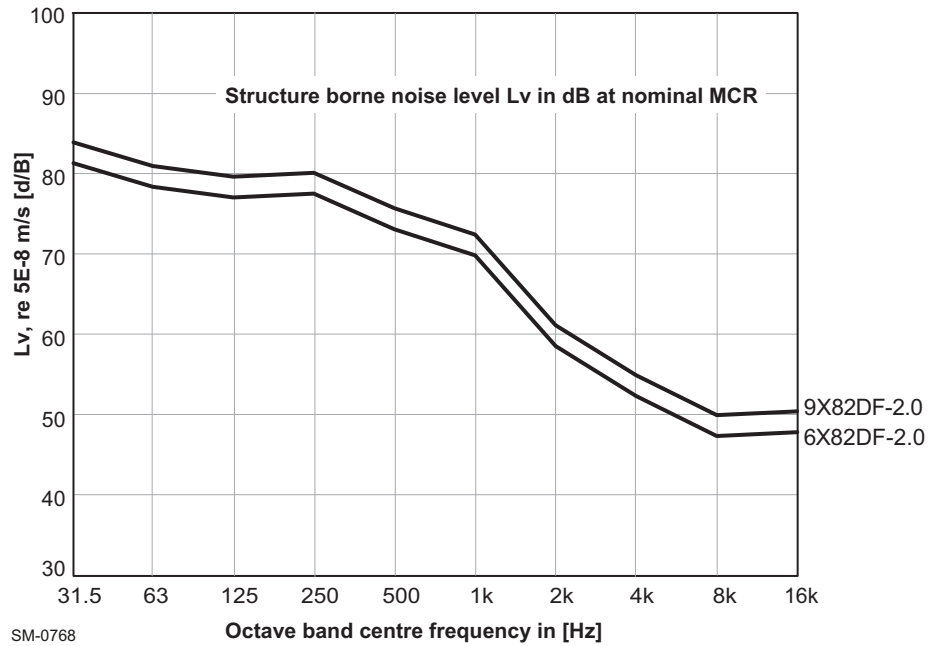

Figure 7-7 Structure-borne noise level at engine feet vertical

8 Engine Dispatch

This chapter describes the provisions to be made for transporting the engine from the engine builder to the shipyard or final destination.

Engines are transported complete or as part assemblies, depending on the terms of contract.

8.1 Engines to be transported as part assemblies

- Engines to be transported as part assemblies have to be systematically disassembled and cleaned using dry cloths.
- Each item is to be clearly identified with 'paint ball' pen, similar indelible marker ink, or figure and letter stamps.
- To ensure correct reassembly and eliminate the risk of parts from one cylinder unit being fitted to another by mistake, it is indispensable that bearings and running gear are clearly marked cylinder by cylinder.

8.2 Protection of disassembled engines

All parts have to be protected against damage by careful crating and from corrosion by applying rust preventing oils or paper.



For further details refer to the latest version of the relevant **Guideline** (DG 0345), which is provided on the WinGD webpage under the following link:

[Guideline for engine protection](#)

8.3 Removal of rust preventing oils after transport

8.3.1 Internal parts

The rust preventing oils applied to the internal parts of an assembled engine have properties similar to lubricating oils. As they do not contain thickening agents of wax type they will wash off easily and mix without causing harm to the engine or its systems.

8.3.2 External parts

Wax type rust preventing oils applied to exposed surfaces of engine components contain thickening agents of wax, forming an anti-corrosion coating when applied. This coating has to be washed off with gas oil, kerosene or white spirit.

9 Appendix

The Appendix gives an overview of the relevant classification societies and lists acronyms mentioned throughout this document in alphabetical order. Tables of SI dimensions and conversion factors can also be found here.

9.1 Classification societies

Table 9-1 List of classification societies

IACS	International Association of Classification Societies		
ABS	American Bureau of Shipping	KR	Korean Register
BV	Bureau Veritas	LR	Lloyd's Register
CCS	Chinese Classification Society	NK	Nippon Kaiji Kyokai
CRS	Croatian Register of Shipping	PRS	Polski Rejestr Statkow
DNV	Det Norske Veritas	RINA	Registro Italiano Navale
IRS	Indian Register of Shipping	RS	Russian Maritime Register of Shipping

9.2 List of acronyms

Table 9-2 List of acronyms

AE	Auxiliary Engine	DG	Design Group
ALM	Alarm	DMB, DFB/ DMA, DFA, DMZ, DFZ	Diesel oil quality grades as per ISO 8217
AMS	Alarm and Monitoring System	ECA	Emission Control Area
BFO	Bunker Fuel Oil	ECR	Engine Control Room
BN	Base Number	ECS	Engine Control System
BOG	Boil-Off Gas	EEDI	Energy Efficiency Design Index
BOR	Boil-Off Rate	EGC	Exhaust Gas Cooler
BPV	Back Pressure Valve	EIAPP	Engine International Air Pollution Prevention
BSEC	Brake Specific Energy Consumption	EM	Engine Margin
BSEF	Brake Specific Exhaust gas Flow	EMA	Engine Management & Automation
BSFC	Brake Specific Fuel Consumption	FBOG	Forced Boil-Off Gas
BSGC	Brake Specific Gas Consumption	FGSS	Fuel Gas Supply System
BSPC	Brake Specific Pilot fuel Consumption	FPP	Fixed Pitch Propeller
BSR	Barred Speed Range	FQS	Fuel Quality Setting
CCR	Conradson Carbon Residue	FRV	Flow Regulating Valve
CCW	Cylinder Cooling Water	FSM	Fuel Sharing Mode
CCWC	Cylinder Cooling Water Cooler	FW	Freshwater
CEN	European Committee for Standardization www.cen.eu	GAV	Gas Admission Valve
CFR	Certified Flow Rate	GCU	Gas Combustion Unit
CMCR	Contracted Maximum Continuous Rating (Rx)	GTD	General Technical Data (application)
CPP	Controllable Pitch Propeller	GVU	Gas Valve Unit
CSM	Combustion Stability Mode	HFO	Heavy Fuel Oil
CSR	Continuous Service Rating	HMI	Human-Machine Interface
DAH	Differential pressure Alarm, High	HP	High Pressure
DBT	Delta Bypass Tuning	HT	High Temperature
DCC	Dynamic Combustion Control	IACS	Int. Association of Classification Societies www.iacs.org.uk
DENIS	Diesel Engine coNtrol and optImising Specifi- cation	iCAT	Integrated Cylinder lubricant Auto Transfer
DF	Dual-Fuel	ICC	Intelligent Combustion Control
DFO	Diesel Fuel Oil, covering MDO (DMB, DFB) and MGO (DMA, DFA, DMZ, DFZ)	iCER	Intelligent Control by Exhaust Recycling

iELBA	Integrated Electrical Balancer	MIM	Marine Installation Manual
IGC (Code)	Int. Code of the Construction and Equipment of Ships Carrying Liquefied Gases in Bulk (International Gas Carrier (Code))	MN	Methane Number
IGF (Code)	International Code of Safety for Ships using Gases or other Low-Flashpoint Fuels	NAS	National Aerospace Standard
iGPR	Integrated Gas Pressure Regulation (unit)	NBOG	Natural Boil-Off Gas
IMO	International Maritime Organization www.imo.org	NO _x	Nitrogen Oxides
iSCR	Integrated Selective Catalytic Reduction	NR (Curve)	ISO Noise Rating (Curve)
ISO	International Organization for Standardization www.iso.org	OM	Operational Margin Operation Manual
LAH	Level Alarm, High	PAL	Pressure Alarm, Low
LAL	Level Alarm, Low	PCS	Propulsion Control System
LCV	Lower Calorific Value	PI	Proportional plus Integral
LDU	Local Display Unit	PLS	Pulse Lubricating System
LFO	Light Fuel Oil	PMS	Planned Maintenance System
LHV	Lower Heating Value	PRU	Power Related Unbalance
LNG	Liquefied Natural Gas	PSV	Purging & Sealing Valve
LO	Lubricating Oil	PTH	Power Take-Home
LOC	Lubricating Oil Cooler	PTI	Power Take-In
LowTV	Low Torsional Vibration	PTO	Power Take-Off
LP	Low Pressure	PTO-G	Power Take-Off Gear
LR	Light Running margin	PUR	Rigid polyurethane
LSH	Level Switch, High	RCS	Remote Control System
LSL	Level Switch, Low	SAC	Scavenge Air Cooler
LT	Low-load Tuning Low Temperature	SAE	Society of Automotive Engineers
MARPOL	International Convention for the Prevention of Pollution from Ships	SCR	Selective Catalytic Reduction
MCR	Maximum Continuous Rating (R1)	SG	Shaft Generator
MDO	Marine Diesel Oil (DMB, DFB)	SHD	Shut-down
ME	Main Engine	SLD	Slow-down
MEP	Mean Effective Pressure	SM	Sea Margin
MEPC	Marine Environment Protection Committee	SOLAS	Int. Convention for the Safety of Life at Sea
MFD	Misfiring Detection (device)	SOV	Shut-Off Valve
MGO	Marine Gas Oil (DMA, DFA, DMZ, DFZ)	SPC	Spare Parts Catalogue Steam Production Control
MIDS	Marine Installation Drawing Set	SPP	Steam Production Power

SPS	Synchro-Phasing System	VI	Viscosity Index
SW	Seawater	VIT	Variable Injection Timing
TBO	Time Between Overhauls	WECS	WinGD Engine Control System
TC	Turbocharger	WHR	Waste Heat Recovery
tEaT	Temperature Exhaust gas After Turbocharger	WiCE	WinGD Integrated Control Electronics
tEbE	Temperature Exhaust gas Before Economiser	WiDE	WinGD Integrated Digital Expert
TVC	Torsional Vibration Calculation	WinGD	Winterthur Gas & Diesel Ltd.
ULO	Used Lubricating Oil	WMC	Water Mist Catcher
VEC	Variable Exhaust Closing	X-EL	WinGD Electrification Solutions

9.3 SI dimensions for internal combustion engines

Table 9-3 SI dimensions

Symbol	Definition	SI-Units	Other units
a	Acceleration	m/s ²	
A	Area	m ² , cm ² , mm ²	
BSFC	Brake specific fuel consumption	kg/J, kg/(kWh), g/(kWh)	
c	Specific heat capacity	J/(kgK)	
C, S	Heat capacity, entropy	J/K	
e	Net calorific value	J/kg, J/m ³	
E	Modulus of elasticity	N/m ² , N/mm ²	
F	Force	N, MN, kN	
f, v	Frequency	Hz, 1/s	
I	Current	A	
I, J	Moment of inertia (radius)	kgm ²	
l, L	Length	m, cm, mm	
I _a , I _p	Second moment of area	m ⁴	
K	Coefficient of heat transfer	W/(m ² K)	
L	Angular momentum	Nsm	
L _{(A)TOT}	Total A noise pressure level	dB	
L _{(LIN)TOT}	Total LIN noise pressure level	dB	
L _{OKT}	Average spatial noise level over octave band	dB	
m	Mass	t, kg, g	
M, T	Torque moment of force	Nm	
N, n	Rotational frequency	1/min, 1/s	rpm
p	Momentum	Nm	
p	Pressure	N/m ² , bar, mbar, kPa	1 bar = 100 kPa 100mmWG = 1 kPa
P	Power	W, kW, MW	
q _m	Mass flow rate	kg/s	
q _v	Volume flow rate	m ³ /s	
t	Time	s, min, h, d	
T, Θ, t, θ	Temperature	K, °C	
U	Voltage	V	
V	Volume	m ³ , dm ³ , l, cm ³	
v, c, w, u	Velocity	m/s, km/h	Kn

Symbol	Definition	SI-Units	Other units
W, E, A, Q	Energy, work, quantity of heat	J, kJ, MJ, kWh	
Z, W	Section modulus	m ³	
$\Delta T, \Delta \Theta, \dots$	Temperature interval	K, °C	
α	Angular acceleration	rad/s ²	
α	Linear expansion coefficient	1/K	
$\alpha, \beta, \gamma, \delta, \varphi$	Angle	rad, °	
γ, σ	Surface tension	N/m	
η	Dynamic viscosity	Ns/m ²	
λ	Thermal conductivity	W/(mK)	
ν	Kinematic viscosity	m ² /s	cSt, RW1
ρ	Density	kg/m ³ , kg/dm ³ , g/cm ³	
σ, τ	Stress	N/m ² , N/mm ²	
ω	Angular velocity	rad/s	

9.4 Approximate conversion factors

Table 9-4 Conversion factors

Length	1 in	=	25.4 mm
	1 ft	= 12 in	= 304.8 mm
	1 yd	= 3 feet	= 914.4 mm
	1 statute mile	= 1760 yds	= 1609.3 m
	1 nautical mile	= 6080 feet	= 1853 m
Mass	1 oz	=	0.0283 kg
	1 lb	= 16 oz	= 0.4536 kg
	1 long ton	=	1016.1 kg
	1 short ton	=	907.2 kg
	1 tonne	=	1000 kg
Volume (fluids)	1 Imp. pint	=	0.568 l
	1 U.S. pint	=	0.473 l
	1 Imp. quart	=	1.136 l
	1 U.S. quart	=	0.946 l
	1 Imp. gal	=	4.546 l
	1 U.S. gal	=	3.785 l
	1 Imp. barrel	= 36 Imp. gal	= 163.66 l
	1 barrel petroleum	= 42 U.S. gal	= 158.98 l
Force	1 lbf (pound force)	=	4.45 N
Pressure	1 psi (lb/sq in)	=	6.899 kPa (0.0689 bar)
Velocity	1 mph	=	1.609 km/h
	1 knot	=	1.853 km/h
Acceleration	1 mphps	=	0.447 m/s ²
Temperature	1 °C	=	0.55 x (°F -32)
Energy	1 BTU	=	1.06 kJ
	1 kcal	=	4.186 kJ
Power	1 kW	=	1.36 bhp
	1 kW	=	860 kcal/h
Volume	1 in ³	=	16.4 cm ³
	1 ft ³	=	0.0283 m ³
	1 yd ³	=	0.7645 m ³

Area	1 in ²	=	6.45 cm ²
	1 ft ²	=	929 cm ²
	1 yd ²	=	0.836 m ²
	1 acre	=	4047 m ²
	1 sq mile (of land)	= 640 acres =	2.59 km ²

Winterthur Gas & Diesel in brief

Winterthur Gas & Diesel Ltd. (WinGD) is a leading developer of low-speed gas and diesel engines used for propulsion power in merchant shipping. WinGD sets the industry standard for environmental sustainability, reliability, efficiency and safety. WinGD provides designs, training and technical support to engine manufacturers, shipbuilders and ship operators worldwide. Headquartered in Winterthur, Switzerland, since its inception as the Sulzer Diesel Engine business in 1893, it carries on the legacy of excellence in design.

www.wingd.com